

Seating Specification Guide

What's New?

What's New information is now available on the in2.steelcase.com Web site. Go to *What's New*, then *Show News by Category*, then *Incentives, Pricing, Promotions*.

▶ See the *Specification Guide Library: Reference Guide* for information about where to find products.

Availability

Electronic price list updated with release 158.C (U.S.) and 135.C (Canada), dated July 19, 2004.

▶ For a list of all trademarks, refer to the last page of this specification guide.



For Canadian Pricing

Calculate in the following order to avoid rounding errors:

- Multiply the base price and each option by 1.38.
- Round each to the nearest dollar.
- Add base and options for total list price.

Statement of Line	2
Work Being Performed	8
Basics of Ergonomic Seating	9
Basics of Adjustability	10
Additional Resources	12

Product Information

Work Chairs

Leap 462 Series	13
Leap 464 Series WorkLounge	61
Criterion 453 Series	71
Think 465 Series	89
Drive 461 Series	115
Jersey Series	125
Sensor 458 Series	139
Rally 457 Series	159
Protegé 433 Series	169
Cachet 487 Series	179
Leap 462 Series High Density	193

Multi-Use Chairs

Ally 463 Series	221
Player 475 Series	227
Snodgrass 474 Series	245
Jersey Series	252
Sensor 458 Series	252
Rally 457 Series	252
Protegé 433 Series	252
Cachet 487 Series	252

Stackable Chairs

Parade! 470 Series	253
Max-Stacker 472 Series	261
Max-Stacker II 473 Series	271

Surface Materials

Resources	295
------------------	------------

Statement of Line

Work Chairs

Leap 462 Series



Full- or High-Back
Ribbon Backframe
Work Chairs
Standard Upholstery
on Back and Seat
▶ Page 36



Full- or High-Back
Ribbon Backframe
Work Chairs
Pillowed Upholstery
on Back and Seat
▶ Page 38



Full- or High-Back
Ribbon Backframe
Work Chairs
Bare-Back and
Standard Upholstery
on Seat
▶ Page 40



Full- or High-Back
Ribbon Backframe
Work Chairs
Bare-Back and
Pillowed Upholstery
on Seat
▶ Page 42



Full-Back
Ribbon Backframe
Stools
Standard Upholstery
on Back and Seat
▶ Page 44



Full-Back
Ribbon Backframe
Stools
Pillowed Upholstery
on Back and Seat
▶ Page 46



Full-Back
Ribbon Backframe
Stools
Bare-Back and
Standard Upholstery
on Seat
▶ Page 48



Full-Back
Ribbon Backframe
Stools
Bare-Back and
Pillowed Upholstery
on Seat
▶ Page 50



Full- or High-Back
Arch Backframe
Work Chairs
Standard Upholstery
on Back and Seat
▶ Page 56

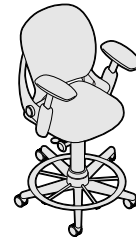

Full-Back
Arch Backframe
Stools
Standard Upholstery
on Back and Seat
▶ Page 58



High-Back
Ribbon Backframe
Work Chairs
Coach Leather on
Back and Seat
▶ Page 34

Leap 464 Series WorkLounge



Ribbon Backframe
WorkLounge
▶ Page 66

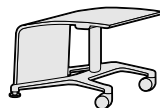

Ottoman
▶ Page 67



Ribbon Backframe
WorkLounge with
Coach Leather
▶ Page 68

Work Chairs, continued

Criterion 453 Series



High-Back
Work Chairs
▶ Page 78



Mid-Back
Work Chairs
▶ Page 80



High-Back
Stools
▶ Page 82



Mid-Back
Stools
▶ Page 84



Plus High-Back
Work Chair
▶ Page 86

Think 465 Series



Work Chairs
▶ Pages 96–113



Work Chairs
with Headrest
▶ Pages 98–113

Drive 461 Series



Full-Back
Work Chairs
▶ Page 122



Mid-Back
Work Chairs
▶ Page 122

Jersey Series



Work Chairs
▶ Page 132



Multi-Use Chairs
▶ Page 134

Work Chairs, continued

Sensor 458 Series



Size II
Adjustable
High-Back
Work Chairs
▶ Page 146



Size II
Adjustable-Back
Work Chairs
▶ Page 148



Size II
High-Back
Work Chairs
▶ Page 150



Size II
Mid-Back
Work Chairs
▶ Page 152



Size II
Mid-Back
Sled-Base
Multi-Use Chairs
▶ Page 154



Size I
Mid-Back
High Stools
▶ Page 156

Rally 457 Series



High-Back
Work Chairs
▶ Page 164



Mid-Back
Work Chairs
▶ Page 164



Mid-Back
Multi-Use Chairs
▶ Page 166



Mid-Back
Sled-Base
Multi-Use Chairs
▶ Page 166

Protegé 433 Series



Work Chairs
▶ Page 174



Multi-Use Chairs
▶ Page 176



Sled-Base
Multi-Use Chairs
▶ Page 178

Cachet 487 Series



Swivel-Base
Work Chair
▶ Page 184



Leg-Base*
Multi-Use Chair
Without Arms
▶ Page 186



Leg-Base*
Multi-Use Chair
With Flip-Up Arms
▶ Page 186

*Cachet leg-base chair models also stack.

Work Chairs, continued

Leap 462 Series High Density



HD Back and Seat
Ribbon Backframe
Work Chairs
Standard Upholstery
on Back and Seat
▶ Page 200



HD Back and Seat
Ribbon Backframe
Work Chairs
Pillowed Upholstery
on Back and Seat
▶ Page 202



HD Back and Seat
Ribbon Backframe
Work Chairs
Bare-Back and
Standard Upholstery
on Seat
▶ Page 204



HD Back and Seat
Ribbon Backframe
Work Chairs
Bare-Back and
Pillowed Upholstery
on Seat
▶ Page 206



HD Back and Seat
Ribbon Backframe
Stools
Standard Upholstery
on Back and Seat
▶ Page 208



HD Back and Seat
Ribbon Backframe
Stools
Pillowed Upholstery
on Back and Seat
▶ Page 210



HD Back and Seat
Ribbon Backframe
Stools
Bare-Back and
Standard Upholstery
on Seat
▶ Page 212



HD Back and Seat
Ribbon Backframe
Stools
Bare-Back and
Pillowed Upholstery
on Seat
▶ Page 214

Tip: Leap High Density (HD) chairs are scaled to allow a seat width 1" narrower than Leap 462 Series Work Chairs while reducing overall lateral width by 4". Plan with Leap HD for environments where space constraints are an issue.

▶ See page 198 for specific dimensional comparisons.

Multi-Use Chairs

Ally 463 Series



Sled-Base
Multi-Use Chair
With Arms
▶ Page 226



Sled-Base
Multi-Use Chair
Without Arms
▶ Page 226

Multi-Use Chairs, continued

Player 475 Series

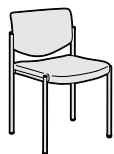

Leg-Base*
Multi-Use Chairs
Without Arms
▶ Page 232



Leg-Base*
Multi-Use Chairs
With Arms
▶ Pages 232–235



Leg-Base
Multi-Use Chairs
With Arms and
Casters
▶ Page 233



Sled-Base
Multi-Use Chairs
Without Arms
▶ Page 236



Sled-Base
Multi-Use Chairs
With Arms
▶ Pages 236–239



Stool With Arms
▶ Page 240



Stool
Without Arms
▶ Page 240

*Player leg-base chair models also stack.

Snodgrass 474 Series



Multi-Use Chairs
With Open Back
With Arms
▶ Page 250



Multi-Use Chairs
With Open Back
Armless
▶ Page 250



Multi-Use Chairs
With Full Back
With Arms
▶ Page 250



Multi-Use Chairs
With Full Back
Armless
▶ Page 250

Jersey Series



Multi-Use Chair
With Arms
▶ Pages 134–135



Multi-Use Chair
Without Arms
▶ Pages 134–135

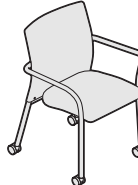

Multi-Use Chair
With Arms and
With Casters
▶ Pages 136–137



Multi-Use Chair
Without Arms and
With Casters
▶ Pages 136–137

Sensor 458 Series



Size II
Mid-Back
Sled-Base
Multi-Use Chairs
▶ Page 154

Rally 457 Series



Mid-Back
Multi-Use Chairs
▶ Page 166



Mid-Back
Sled-Base
Multi-Use Chairs
▶ Page 166

Protegé 433 Series



Multi-Use Chairs
▶ Page 176



Sled-Base
Multi-Use Chairs
▶ Page 178

Multi-Use Chairs, continued

Cachet 487 Series



Leg-Base*
Multi-Use Chair
Without Arms
▶ Page 252



Leg-Base*
Multi-Use Chair
With Flip-Up Arms
▶ Page 252

*Cachet leg-base chair models also stack.

Stackable Chairs

Parade! 470 Series



Stackable Chairs
▶ Page 258

Max-Stacker 472 Series



Stackable Chairs
▶ Page 266

Max-Stacker II 473 Series



Stackable Chairs
▶ Page 276

Work Being Performed

Work Being Performed... Interaction and Autonomy Seating Matrix

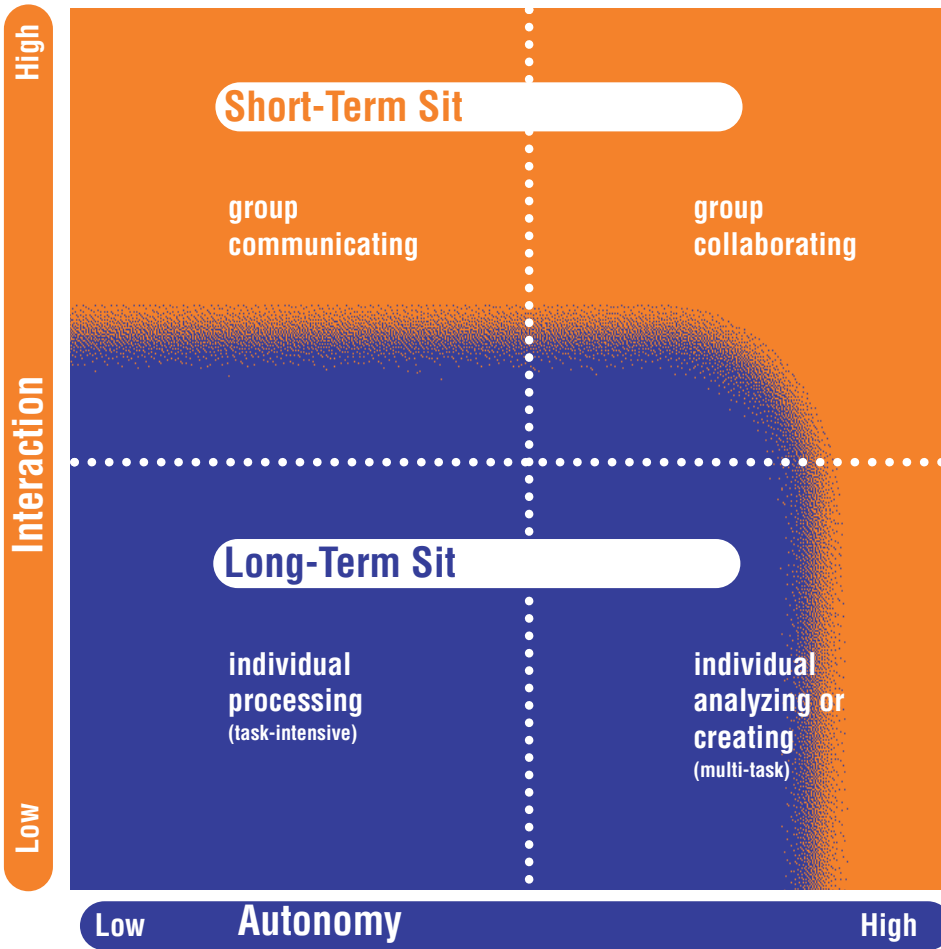

Short-Term Sit

Short periods of sitting
Moderate computer use



Cachet



Rally



Protegé

Long-Term Sit

Long periods of sitting
Heavy computer use



Leap



Criterion



Drive



Sensor



Jersey



Think

Note

- The more repetitive the task (individual processing work), the more critical it is to have a long-term, sit chair with full adjustability.
- In some cases, a short-term, sit chair can be used for short-term, individual analyzing or creating.

Basics of Ergonomic Seating

Proper ergonomic seating can help workers perform more efficiently and avoid muscle and eye strain.

Neck is straight or slightly forward.

Shoulders are relaxed so arms hang naturally.

Back has full contact with the backrest (sit all the way back in your chair).

Elbows and forearms can rest comfortably on the arms of your chair, or on worksurfaces that are used for writing, paperwork, and other tasks.

Lower back fits into curved lumbar support.

Tension is adjusted so backrest tilts easily, yet provides smooth, even support.

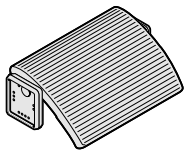

If worksurfaces and keyboard support are not height-adjustable, raise your chair's seat height to achieve the appropriate relationship to your tasks. If this leaves your feet dangling above the floor, use a Details footrest.

Call Details, 1.800.833.0411, or your Steelcase dealer, for additional information or price list.

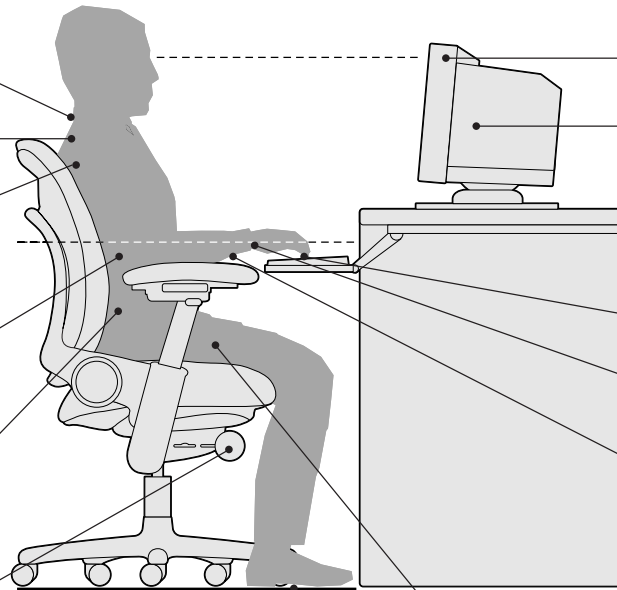

Top of monitor should be at eye level.

Screen is 20 to 30 inches from the eyes.

Screen is at eye level slightly lower and directly in front of worker so head is not turned.

Keyboard is at elbow height.

Wrists should be straight when keying or mousing, not bent up or down.

When keying or mousing, forearms are parallel to the floor.

Thighs are parallel to the floor.

Feet are flat on the floor or on a footrest.

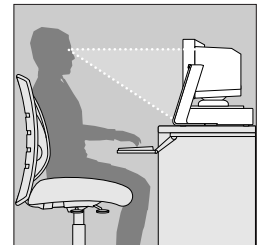

Keep frequently viewed objects, such as a VDT or source document, at or below the horizontal line of sight. Arrange display screen and documents to be equidistant from your eyes.

ANSI/BIFMA is the American National Standards Institute/Business and Institutional Furniture Manufacturer's Association. All Steelcase furniture meets or exceeds ANSI/BIFMA standards for structural quality. All Steelcase Seating products also follow the ergonomic guidelines established in BIFMA G1-2002.

Basics of Adjustability

Steelcase chairs offer varying levels of adjustability to meet the needs of many types of users. Adjustable chairs may offer one or more of these features:

Mechanisms



Natural-glide feature causes the seat to slide forward as the user reclines, keeping the user within his or her vision and reach zone (462, 464).



Advanced swivel-tilt feature incorporates a no front-rise design that allows the seat to remain level even when the user leans back (453, 457, 433).



Synchro-tilt feature means the chair back and seat are synchronized to move in a 2:1 ratio. When the user leans back, the seat rises only half as much, allowing the user's feet to remain flat on the floor (461, 458, Jersey).



Your Power weight-activated feature allows for an amount of recline resistance that is directly proportional to the user's weight. The natural-glide feature keeps the user within vision and reach zone (465).



Balanced Action Rocker (BAR) mechanism allows users to recline as the seat flexes. BAR relies on physics to let any user, regardless of posture, height, or weight, find the most comfortable position (487).

Seat Adjustments



Pneumatic height adjustment allows the user to remain seated while adjusting the seat height by way of a control button or lever (all work chairs).



Seat edge angle allows front edge of seat to drop down while seat angle remains unchanged (462).



Seat angle adjustment allows the user to change the angle of the seat to a forward position (453, 461, Jersey).



Seat edge flex Seat edge naturally tilts to relieve pressure under the user's thighs (465).



Seat depth adjustment allows the user to slide the seat forward or back (462, 453, 461, 465, Jersey).

Back Adjustments



Lumbar height affords additional lower back support. Grasp lumbar handles and slide up or down to adjust (462, 453, 461, 465).



Lower back firmness changes the amount of firmness user feels in lower back (462, 464).



Upper back tension feature provides an increasing amount of force that increases as the user reclines (462, 464).



Back tension adjustment allows the user to control the amount of resistance felt when leaning back in the chair (all chairs except 462, 465, 487).



Your Preference back control includes four settings—weight-activated, boosted, mid-stop, and upright—that allow for personal preference and work styles (465).



Headrest adjustment allows the user to support head and neck in upright or reclined posture (464, 465).



Variable back stop allows the user to lock the back upright or to preset the range of recline (462, 453, 458, 464).



Upright back lock allows the user to lock the backrest in a full upright position or release it for full recline (461, 457, 433, Jersey).



Back height adjustment allows the user to raise or lower the chair back (453, 458).

Arm Adjustments



Arm height adjustment allows the user to move the arms up or down independently (462, 453, 461, 458, 465, Jersey).



Arm width adjustment allows the user to move the arms in or out independently (462, 453, 461, 458, Jersey).



Arm pivot adjustments allows the user to position arm rests as appropriate for the task being performed (462, 453, 461, 465, Jersey).



Arm depth adjustment allows users to get closer to their work by chair arms moving out of the way (465).

Other Features



Foot ring height can be adjusted up or down for user comfort. Cannot be done from seated position (462, 453, 458).

Work Chair Adjustability Features For Long-Term Sitting

	Leap 462 Series ▶Page 13 ▶Page 193 (HD)	Leap 464 Series WorkLounge ▶Page 61	Criterion 453 Series ▶Page 71	Criterion Plus 453 Series ▶Page 71	Think 465 Series ▶Page 89	Drive 461 Series ▶Page 115	Jersey Series ▶Page 125	Sensor 458 Series ▶Page 139
Mechanisms								
Natural glide	•	•						
Your Power					•			
Advanced swivel-tilt			•	•				
Synchro-tilt						•	•	•
Seat Adjustments								
Pneumatic height	•	•	•	•	•	•	•	•
Seat edge angle	•				•			
Seat angle			•	•		•	•	
Seat depth	•		•	•*	•	•	•	
Back Adjustments								
Lumbar height	•		•	•	•	•		•
Lower back firmness	•	•						
Upper back tension	•	•						
Back tension			•	•	•	•	•	•
Variable back stop	•	•	•					•
Upright back lock				•	•	•		•
Back height			•	•				•
Arm Adjustments								
Arm height	•		•	•	•	•	•	•
Arm width	•		•	•		•	•	•
Arm pivot	•		•		•	•	•	
Arm depth					•			
Other Features								
Foot ring height (stool)	•		•					•
Headrest		•			•			

*See product understanding pages for additional details.

Work Chair Adjustability Features For Short-Term Sitting

	Rally 457 Series ▶Page 159	Protegé 433 Series ▶Page 169	Cachet 487 Series ▶Page 179
Mechanisms			
Advanced swivel-tilt	•	•	
Balanced Action Rocker (BAR)			•
Seat Adjustments			
Pneumatic height	•	•	•
Back Adjustments			
Back tension	•	•	
Upright back lock	•	•	
Self adjusting			•

Additional Resources

Steelcase seating is supported with an array of informational materials, tools, and software to help you plan efficiently.

Product brochures and planning tools can be ordered through your Steelcase area office, by calling 1.800.784.0355, or through the Steelcase Marketing Communications Web site at in2.steelcase.com.

Printed Materials

Seating Overview

This full-color overview divides chairs into three categories—work chairs, multi-use chairs, and lounge. The overview brochure includes a four-page foldout that contains a visual index and shows customers the array of Steelcase Inc. seating lines. *Form number 03-0003368*

Planning Tools

Quick Delivery Handbook

This handbook describes all Steelcase, Turnstone, Details, and Steelcase Design Partnership products that are available for 3-Day (3-day shipment), Express12 (12-day delivery), or 15-Day (15-day shipment).

Surface Materials

Surface Materials Reference Manual

This publication provides:

- An explanation of the surface materials and their categories
- “Available on” matrices
- Vertical surface fabric and seating upholstery selection listing
- Pricing for surface materials
- Technical data for surface materials
- Surface material care and cleaning instructions

Additional surface materials specification tools

are available to assist you in the specification process—the Surface Materials Binders and the Surface Materials Tool Box.

Surface Materials Finishes Binder

includes:

- Surface Materials Reference Manual
- A complete set of swatch cards for hard surfaces

Surface Materials Vertical Surface Fabric Binder

includes:

- A complete set of swatch cards for vertical surface fabric

Surface Materials Seating Upholstery Binder

includes:

- Designtex Graded-In Catalog
- A complete set of swatch cards for seating upholstery

Surface Materials Tool Box

provides 3" x 3" samples of the following surface materials:

- Seating upholstery
- Wood
- Paint
- Laminate

Form number S8150

Customer's Own Material (COM) Web site

features fabric test results for all COM fabrics which have been tested by Steelcase and also allows you to calculate yardage requirements for most Steelcase seating lines. The Web site will always contain the most current information available, providing the same information you would receive if you called or faxed a COM Consultant. To locate the COM Web site:

- Visit www.steelcase.com
- Click on “Knowledge & Design”
- Select “Customer's Own Material”

Computer Tools



Product Info

Electronic versions of this and many other specification guides in Acrobat PDF (Portable Document Format) allow you to scan, search, and print any page on virtually any computer. You can access these files at the Steelcase.com Web site or My Sales Online at in2.Steelcase.com.

Electronic Catalog

Accurate sales quotations and purchase orders for Steelcase products are created with specification software that uses Steelcase Electronic Catalog data. Use the data to specify and price style numbers and options for every Steelcase product. The data is updated quarterly by Steelcase and provided to software programs like the Hedberg Business System, 20-20 CAP Studio, and 20-20 Office Sales.

Furniture Symbol Graphic Data

Steelcase creates 2D and 3D furniture symbols (with attributes) for planning and initially specifying Steelcase products. This data is incorporated into several add-on software packages that work in either a Microstation or an AutoCAD drafting environment.

More Information

For more information on these and other software tools to help you plan effective work environments, please contact Steelcase eTools at 1.616.246.9542.

Support

Steelcase Capabilities

Steelcase products are distributed, installed, and serviced through a network of more than 600 dealers worldwide. Steelcase is also represented with offices and corporate showrooms in 26 U.S. cities, 4 Canadian cities, and in France, Germany, Great Britain, and Japan. Every Steelcase product meets our exceptionally high standards of quality and durability and comes with the Steelcase assurance of excellence in service.

For assistance,

please call your local dealer, the Steelcase Solutions Resource Team, or the Steelcase Solutions Fulfilled Team at 1.888.STEELCASE (1.888.783.3522).

Call the Steelcase Solutions Resource Team prior to placing an order, when working on a bid, or when you need information about product applications and specifications.

Call the Steelcase Solutions Fulfilled Team if you have submitted an order to Steelcase and you need to speak to your service representative about the order. Also call if you have any post-shipment quality or warranty concerns or service parts questions.

Outside the U.S.A., Canada, Mexico, Puerto Rico, and the U.S. Virgin Islands, call 1.616.247.2500.

For information about Steelcase, the name of your nearest Steelcase dealer, or for product literature, call 1.800.333.9939 or visit our Web site: www.steelcase.com.

Understanding and Specifying Leap 462 Series Work Chairs

Understanding Leap 462 Series

Overview	14
Understanding Backframe and Upholstery Differences	15
Standard Upholstery	16
Pillowed Upholstery	17
Bare-Back	18
Coach Leather	20
Details	22
Dimensions	26

Specifying Leap 462 Series

Value Packages

Ribbon Backframe Work Chairs

Standard Upholstery Fabric	28
Pillowed Upholstery Fabric	30

Arch Backframe Work Chairs

Standard Upholstery Fabric	32
----------------------------	----

Ribbon Backframe

Coach Edition Leather Work Chairs

Standard Upholstery on Back and Seat	34
Pillowed Upholstery on Back and Seat	36
Bare-Back and Standard Upholstery on Seat	38
Bare-Back and Pillowed Upholstery on Seat	40
Bare-Back and Pillowed Upholstery on Seat	42

Stools

Standard Upholstery on Back and Seat	44
Pillowed Upholstery on Back and Seat	46
Bare-Back and Standard Upholstery on Seat	48
Bare-Back and Pillowed Upholstery on Seat	50

Pillowed Upholstery Packages

Vest Packages	52
---------------	----

Arch Backframe

Work Chairs

Standard Upholstery on Back and Seat	56
--------------------------------------	----

Stools

Standard Upholstery on Back and Seat	58
--------------------------------------	----

Work Chairs

Highly adjustable task seating offers maximum personalization for people who sit most of the day performing repetitive tasks. By making a series of simple adjustments, you can customize the chair to your body, preferences, and tasks. These chairs provide continuous, stable, task-oriented comfort, and can be quickly adjusted to support you in upright, forward, and reclining work postures.

- Leap 462 Series
- Leap 464 Series WorkLounge
- Criterion 453 Series
- Think 465 Series
- Drive 461 Series
- Jersey Series
- Sensor 458 Series

Adjustability Features

▶ See page 11 for a comparison to other chairs. **Leap 462 Series**

Mechanisms

Natural glide ●

Seat Adjustments

Pneumatic height ●

Seat edge angle ●

Seat depth ●

Back Adjustments

Lumbar height ●

Lower back firmness ●

Upper back tension ●

Variable back stop ●

Arm Adjustments

Arm height ●

Arm width ●

Arm pivot ●

Other Features

Foot ring height (stool) ●

Overview

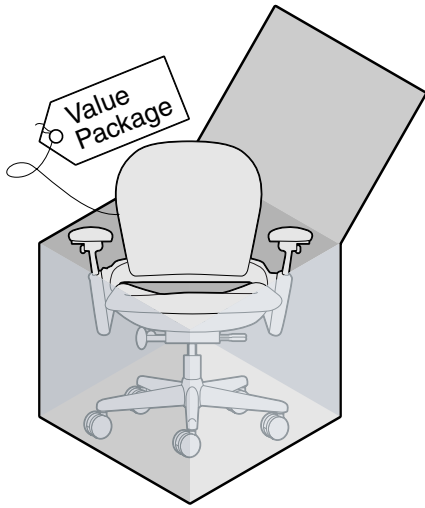

Value packages are available for the most common Leap chair configurations to meet the needs of typical high-performance workspaces. Value packages allow you to obtain the full array of Leap chair features at a lower price than you would pay if you assembled these features individually. To simplify specifying, value packages include no options other than fabric price group and plastic color choices.

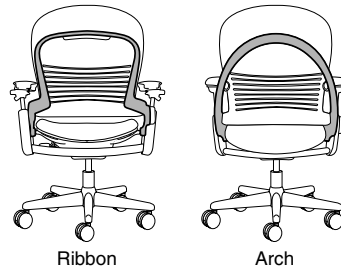

Two backframe designs are available on Leap chairs. The ribbon backframe offers a lighter design. The arch backframe creates a more robust look.

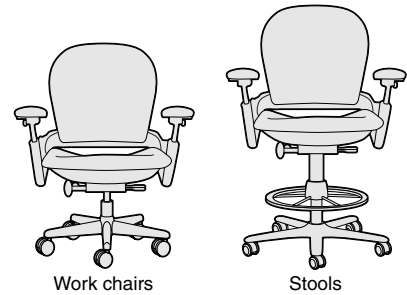

Work chairs are available for use throughout the office.

Stools are available in full back only and are for applications with high worksurfaces. Stools are standard with the same adjustment features as work chairs.



Features and flexibility are built in to every Leap chair so active users can adjust the chair to suit their requirements. For more utilitarian applications or when there is a restricted budget, you can choose options that eliminate Leap chair features while lowering costs.

Understanding Backframe Differences

Ribbon Backframe		Arch Backframe	
<p>Backframe is flexible in a vertical motion. • Back follows the posture of the back and • Maintains angle between sitting and standing.</p>		<p>Backframe frame is constructed using arch that securely transmits force to the base of the spine.</p>	
Fabric	Leather	Fabric	Leather
 Standard #Page 6	 Standard with optional edge detail (optional) #Page 6	 Standard #Page 6	 Standard with optional edge detail (optional) #Page 6
Pillow #Page 6	Pillow #Page 6	Pillow #Page 6	Pillow #Page 6
Standard seat #Page 6	Backrest with standard seat and seat options #Page 6	Standard seat #Page 6	Backrest with standard seat and seat options #Page 6
Standard seat #Page 6	Backrest with standard seat and seat options #Page 6	Standard seat #Page 6	Backrest with standard seat and seat options #Page 6

Leap Seating Product Division

Choose from a variety of upholstery choices. Standard or pillowed seat and back upholstery is available in fabric or leather. The bare-back chair is available with standard or pillowed seat upholstery in fabric or leather.
 ▶ Pages 15–21

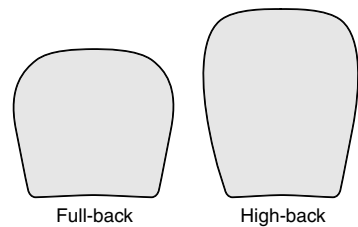

Two back heights available—full back and high back. Full-back chair is adequately proportioned to accommodate the user comfortably. The stately high-back chair offers equal comfort and an additional 3" of height for increased back support. *Tip: Stools are available in full back only.*

Understanding Backframe and Upholstery Differences

Understanding Backframe and Upholstery Differences

Ribbon Backframe



Backframe is a narrow ribbon that mimics the profile of the back and forms angles before joining the arms. Performance matches arch backframe.

Arch Backframe



Backframe forms a continuously curving arch that smoothly transitions into the base of the arms. Performance matches ribbon backframe.

Fabric



Standard
▶ Page 16



Standard with stitched edge detail (option)
▶ Page 16

Leather



Standard with stitched edge detail
▶ Page 16



Coach Bleecker
▶ Page 20

Fabric



Standard
▶ Page 16

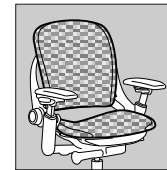

Standard with stitched edge detail (option)
▶ Page 16

Leather



Standard with stitched edge detail
▶ Page 16



Pillowed
▶ Page 17



Pillowed
▶ Page 17



Coach Mercer
▶ Page 20



Bare-back with standard seat
▶ Page 18



Bare-back with vest (option) and standard seat
▶ Page 18



Bare-back with standard seat with stitched edge detail
▶ Page 18



Bare-back with vest (option) and standard seat with stitched edge detail
▶ Page 18



Bare-back with pillowed seat
▶ Page 18



Bare-back with vest (option) and pillowed seat
▶ Page 18



Bare-back with pillowed seat
▶ Page 18



Bare-back with vest (option) and pillowed seat
▶ Page 18

Standard Upholstery

What Is It?

Fabric- or leather-covered, multi-density foam, permanently bonded to the seat and back to form fully cushioned surfaces.

Where Available

Ribbon backframe

- Full-back work chairs
- High-back work chairs
- Full-back stools

Arch backframe

- Full-back work chairs
- High-back work chairs
- Full-back stools

Materials

- Fabric
- Leather
- Vinyl
- COM fabric
- COL leather
- COV vinyl

Classics Collection Upholstery

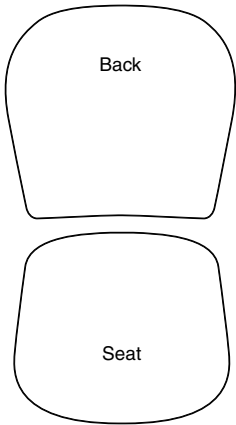

Stitched seams are not included on the cushions of Steelcase Classics Collection standard upholstery chairs.

Leather Upholstery

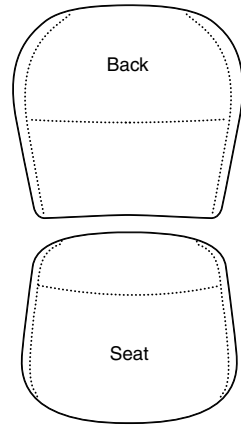

Stitched seams are included on the back cushion and seat cushion of leather and Customer's Own Leather (COL) standard upholstery chairs.

Designtex Graded-In and COM Upholstery

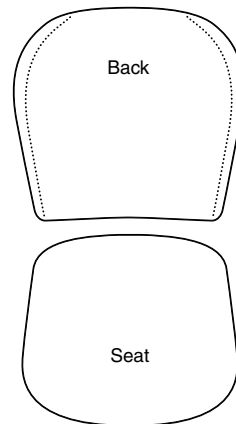

Stitched edge detail is included on the back cushion of Designtex Graded-In fabrics and Customer's Own Material (COM) standard upholstery chairs. If the stitch detail is desired on Steelcase Classics Collection fabrics, there is an additional upcharge.

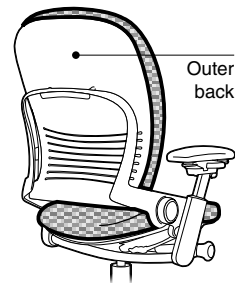

Plastic outer back is fully exposed on chairs with standard upholstery.

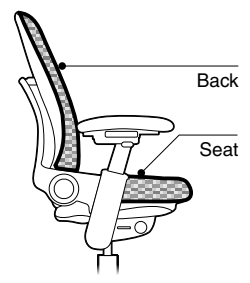

Seat and back cushions are permanently bonded to chair but can be removed and replaced by a technician if damaged.

What Is It?

Two trim pillows—one on the seat and one on the back. Pillows can be easily removed and replaced.

Where Available

- Ribbon backframe**
- Full-back work chairs
 - High-back work chairs
 - Full-back stools

Materials

- Fabric
- Leather
- Vinyl
- COM fabric
- COL leather
- COV vinyl

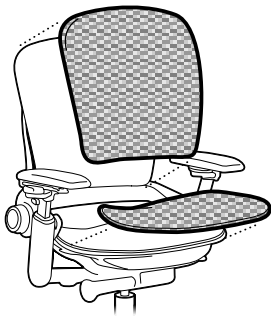

Pillows are removable without tools to allow users to switch or replace them as desired. Pillows can also be removed for cleaning. Replacement pillows are available through this specification guide and Customer Service Parts.

▶ Page 52

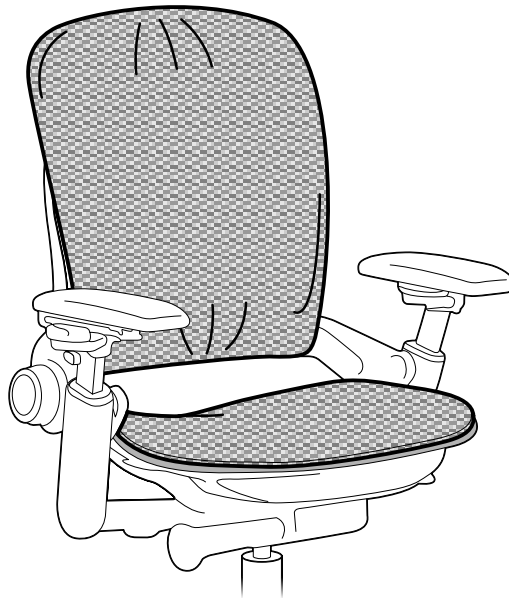

Fabric that overlaps chair back shell matches the fabric on the front of the pillow. Performance fabric is used to construct the back side of the pillow. Color of performance fabric is a default of the specified plastic color.

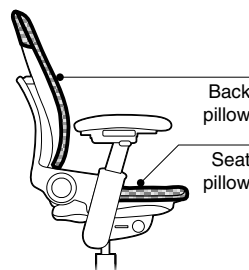

Pillowed upholstery is thin with a lightness that complements chairs with ribbon backframe. Pillowed upholstery creates an informal, relaxed look.

Bare-Back

What Is It?

Bare-back chair has no upholstery on the back to create a clean, minimalist look. Seat is available with standard upholstery or pillowed upholstery.

Where Available

- Ribbon backframe**
- Full-back work chairs
 - High-back work chairs
 - Full-back stools

Materials

- Fabric
- Leather
- COM fabric
- COL leather

Removable vest is available as an option on bare-back models. Replacement vests can be ordered from this specification guide and Customer Service Parts. [▶ Page 55](#)

Back shell is plastic on bare-back chairs.



Standard upholstery seat cushion is available on bare-back chairs. Cushion is permanently bonded to chair but can be removed and replaced by a technician if damaged.

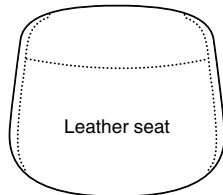

Stitched seams are included on the seat cushion of leather, vinyl, Customer's Own Leather (COL), and Customer's Own Vinyl (COV) standard upholstery chair.

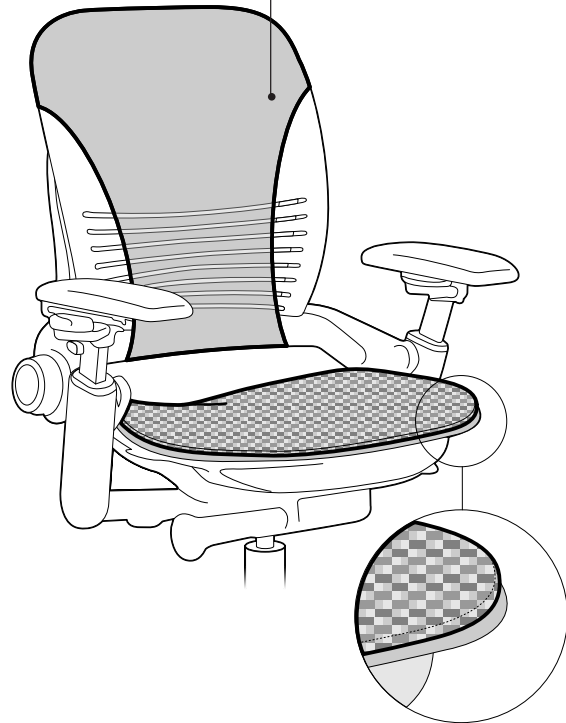

Pillowed upholstery is available on seat of bare-back chairs. Concealed snaps secure pillow to the seat.

Coach Leather

Coach Edition Leather Work Chairs

What Is It?

Coach leather upholstery on seat and back. Two leather pillow back patterns are available—Coach Bleecker and Coach Mercer. Leather back pillows can be easily removed, but the seat cushion is permanently bonded to the seat.

Where Available

- Ribbon backframe**
- High-back work chairs with style numbers consisting of 462COACH only

Materials

- Coach leather with matching thread
- Coach leather with contrasting thread
- Polished aluminum package



Coach Edition Bleecker leather pillow has a raised, quilted pattern. Matching or contrasting thread stitching is available and specified with separate finish numbers.



Coach Edition Mercer leather pillow has a perforated back with raised edge trim. Matching or contrasting thread stitching is available and specified with separate finish numbers.

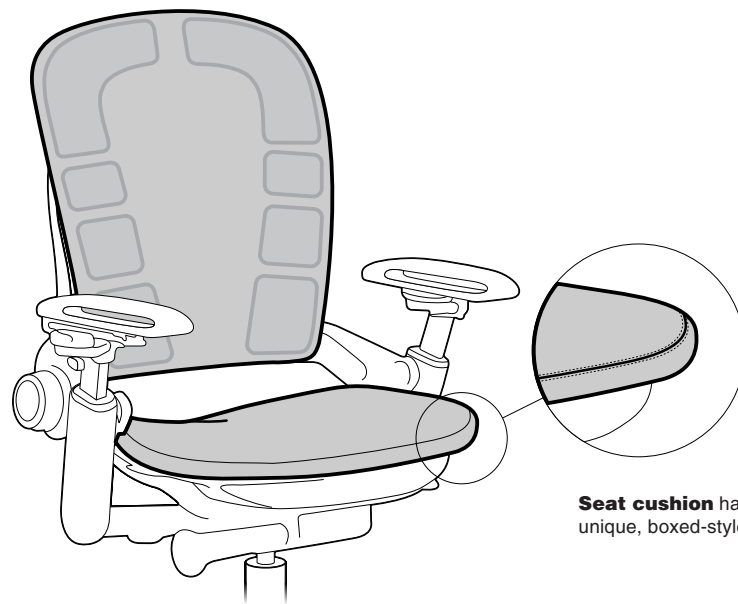

Seat cushion has a unique, boxed-style detail.



Coach emblem is sewn on the back of all Coach pillows.

Leather that overlaps chair back shell matches the leather on the front of the pillow. Performance fabric is concealed and used to construct the back side of the pillow.

Coach Leather Pillowed Upholstery Option

What Is It?

Coach leather available as an option on pillows. Pillows are available with matching thread only and do not have a pattern—Bleecker and Mercer patterns are not available. Back and seat pillows can be easily removed and replaced.

Where Available

- Ribbon backframe**
- Full-back work chairs
 - High-back work chairs
 - Full-back stools

Materials

- Coach leather with matching thread
- Tip: Contrasting thread stitching is not available on pillowed upholstery option.*

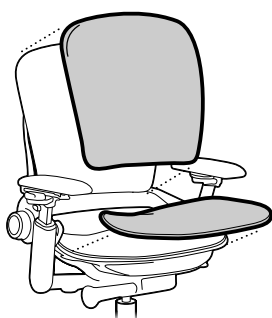

Pillows are removable without tools to allow users to switch or replace them as desired. Pillows can also be removed for cleaning. Replacement pillows are available through this specification guide and Customer Service Parts.
▶ Page 52

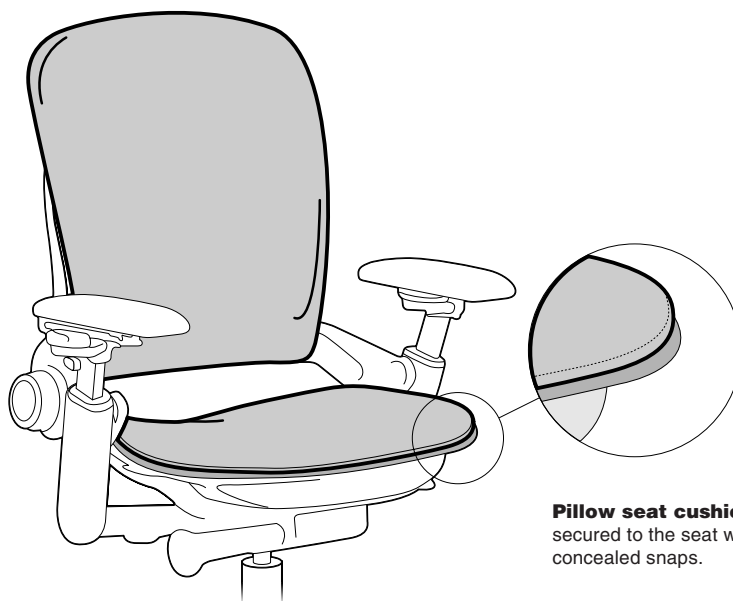

Pillow seat cushion is secured to the seat with concealed snaps.



Coach emblem is sewn on the back of all Coach pillows.

Leather that overlaps chair back shell matches the leather on the front of the pillow. Performance fabric is concealed and used to construct the back side of the pillow.

Leap 462 Series

Leap—a technology, a chair, a healthier way to sit.

Outer back and outer seat are plastic.

Lumbar height 5" of additional lower back support is available as an option on chairs with standard upholstery.

Arm height can adjust independently within a 4" range to help relieve upper back and shoulder fatigue.

Seat depth adjusts within a 3" range on work chairs. Stools adjust 2¼" range. Fixed seat depth models are also available.

Five-arm base is standard.

Casters have hard, dual-wheels that roll smoothly on carpets. They are 3" for increased mobility. Soft, dual-wheel casters are available for use on hard floors or chair mats. Stools are standard with 2" hard casters. Soft casters are available as an option.

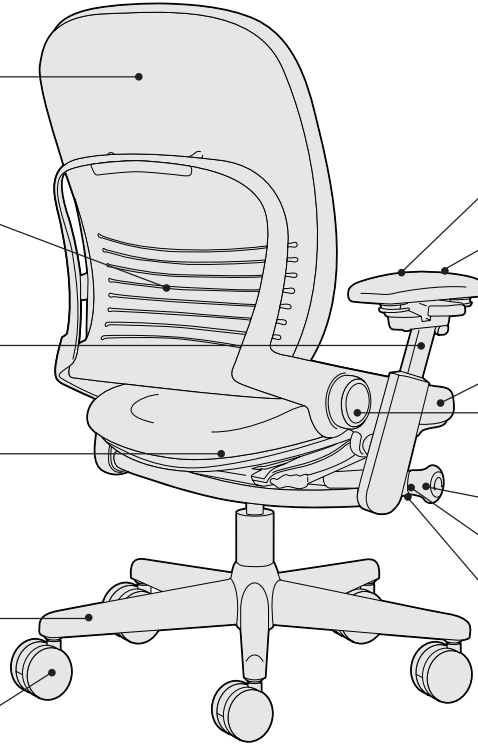

Arm width can adjust within a 3" range for each arm to provide forearm support in neutral position for 5th to 95th percentile office workers.

Arm caps can pivot independently 14° in and 21° out to accommodate individual user preferences.

Seat edge angle allows the front edge of the seat to drop down close to 2°, relieving pressure behind the thighs.

Lower back firmness changes the amount of firmness user feels in lower back. Requires only two complete turns.

Upper back force requires only five complete turns and accommodates a broader range of users by allowing user to change the rate of increase in force as the user reclines.

Seat height adjusts within a 5" range with a pneumatic adjustment mechanism. A 7" range is available as an option. Stools have an 8" range.

Variable back stop with five positions is standard.

Product Details

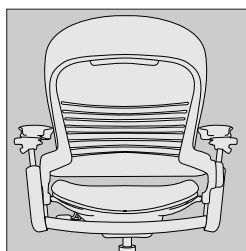

Parallel slats in back shell provide extensive flexibility to allow back to conform to individual users.

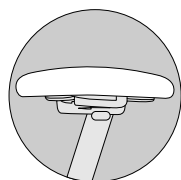

Rectilinear arm caps

- Soft
- Upholstered



See-through arm caps are available on Leap Coach Edition only.

Models are available with fixed seats, adjustable seats that include seat depth and seat edge angle, or adjustable seats that include seat depth only.

Adjustability instructions are included with every chair. Width- and pivot-adjustable arm models include instructions on a removable label concealed under the arm cap.

Controls under the seat include tactile braille designators.

Adjustment Features

Seat Adjustments

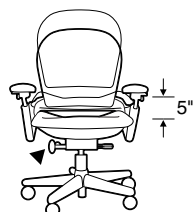

Seat height adjusts pneumatically. To lower, hold handle up while seated. To raise, hold handle up and keep your weight off the chair. Range of adjustability is 5" from 15"H to 20"H and is standard on work chairs. A 7" range of adjustability (15³/₄"H to 22¹/₄"H) is available as an option. An 8" range of adjustability (22"H to 30"H) is available on stools.

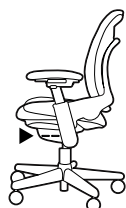

Seat edge angle adjusts by pulling handle up and shifting your weight forward to front edge of seat to alter front edge by close to 2". Release handle to lock. This feature is available on adjustable seat models, work chairs, and stools.

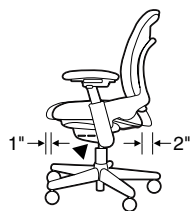

Seat depth adjusts 3" (15¹/₄"–18¹/₄") by pulling handle up. Slide seat forward or back to accommodate various leg lengths. Release handle to lock. This feature is available as an option on work chairs and stools. Stools and armless chairs adjust 2¹/₄" (15¹/₄"–17¹/₂").

Back Adjustments

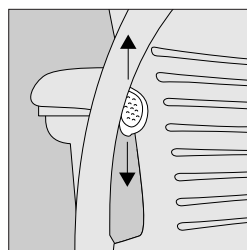

Lumbar height adjusts 5" (5¹/₄" to 10¹/₄" from seat) by grabbing exposed tabs and sliding the lumbar support up or down. This 5" range feature is available as an option on work chairs and stools with standard upholstery only.

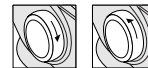
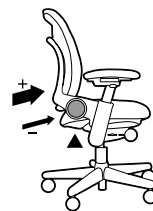

Lower back firmness adjusts by turning knob two complete turns. Forward increases firmness. Backward decreases firmness. This feature is standard on work chairs and stools.

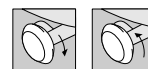
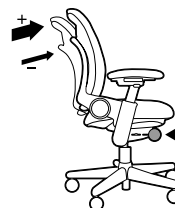

Upper back force adjusts by turning knob five complete turns. Turn knob forward to increase rate of tension; backward to decrease. This feature is standard on work chairs and stools.

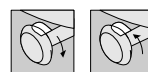
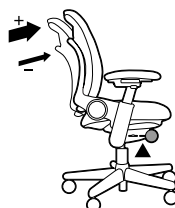

Variable back stop. Rotate handle up or down to set recline angle. Lean back to desired back angle. Five stops are available. This feature is standard on work chairs and stools. *Tip: To stop in upright position, remove weight from back and rotate lever up.*

Arm Adjustments

Rectilinear height-, width-, and pivot-adjustable arms come standard on all arm models of chairs and stools. Fixed-height arms are an option. Also available armless.



Arm height adjusts independently within a range of 4" (7"–11" from the seat). Push button on outside and under arm cap in while moving arms up or down. Releasing buttons locks arms in position.

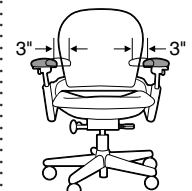

Arm width adjusts 3" each independently on chairs with this option. Grasp arm and move in or out. Range is 13"–19" for both arms.

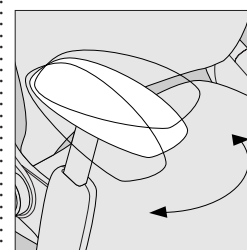

Arms pivot 14° in 21° out independently on models with adjustable-width arms. Grasp arm and push front to left or right. Pivot adjustment adds 2³/₄" to width range (12"–21").

Adjustment Features, continued

Other Features

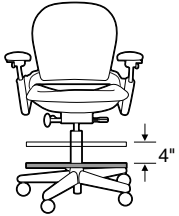

Foot ring height on stools adjusts by first lifting ring and rotating it counter-clockwise to unlock it. Then raise or lower ring up to 4" to desired position before rotating it clockwise to lock it.

Soft-wheel casters for hard floors are available for specific applications.

Surface Materials

▶ See surface materials on page 282 for specific availability or refer to the *Surface Materials Reference Manual* for further information.

Upholstery

- Fabric
- Fabric with soil-retardant treatment (option)
- Leather
- Vinyl

Hard components

(base, outer back, outer seat, and foot ring on stools)

- 6205 Black
- 6259 Midnight
- 6296 Sterling

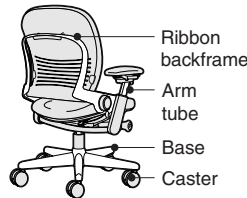

Polished aluminum package is available as an option on ribbon back chairs with arms and 6205 Black frame finish. Stools, armless chairs, and chairs with 7" pneumatic seat-height adjustment option are not available with this package. Polished aluminum is applied to ribbon backframe, arm tube, base and casters.

Arms

- Soft vinyl arm caps: 6205 Black only

Vest

- 5056 Black

All Steelcase seating with standard upholstery fabrics complies with requirements of the BIFMA First Generation Voluntary Upholstered Furniture Flammability Standard, as well as the State of California Technical Bulletin 117. All standard seating is labeled to be in compliance with California TB117.

Programs & Services

▶ See the *Surface Materials Reference Manual* for further detail about programs and services offered for seating.

The Customer's Own Material (COM) Program

offers the opportunity for customers to select fabrics that are not offered through the standard Steelcase surface materials program for use on Steelcase products. Through the COM program, Steelcase will test your materials for application on Steelcase products. Once approved, you can place your order. Steelcase will facilitate the entire ordering process and give you a production schedule. Steelcase will order the COM fabric directly from the textile manufacturer. For up-to-date information regarding fabric test results for all COM fabrics and details regarding yardage requirements for most Seating lines, visit the COM Web site. To locate the COM Web site:

- Visit www.steelcase.com
- Click on "Knowledge & Design"
- Select "Customer's Own Material"

Soil retardants are treatments that provide long-term soil and stain resistance to a fabric without affecting the shade or the integrity of the fabric. The following Steelcase Textiles are available pre-treated with soil retardant. (You do not need to select the soil-retardant option for these fabrics and incur the \$17 upcharge.)

- Canzoné
- Cavalcade
- Jacks
- Link
- Regis
- Rook
- Roulette
- Skittles
- Spyder
- Sweepstakes

Soil-retardant treatment is available on all other seating fabrics at an additional \$17 U.S. per seating unit. To order this option, please select "Soil-Retardant Treatment" under "Optional Accessories."

For soil-retardant treatment on COMs, please select "Soil-Retardant Treatment" under "Optional Accessories." Minimums or additional yardage may be required. Please contact the vendor directly for specific information.

Extended lead times may be necessary for this service.

Contact your Steelcase Sales Service representative at 1.888.STEELCASE (1.888.783.3522).

Fire Codes

▶ See pages 289–290 for upholstery fabrics available for use with FCS modification.

Steelcase offers Fire Code Seating modification (FCS) on nearly all seating models. The most rigorous fire codes in the nation have been developed in California, and the Steelcase FCS modification is designed to meet those codes. Fire Code Seating (FCS) indicates that a product is constructed to meet the strict fire code requirements of high public occupancy areas such as theaters, meeting rooms, and lobbies. The FCS standards will meet both the State of California Home Furnishing Technical Bulletin 133 (Cal TB 133) and Boston Fire Code (BFC). Boston adopted the California Home Furnishing Technical Bulletin TB 133 test standard in 1992.

Local codes may have special requirements for upholstery.

Dimensions

▶ Page 26

Resources

Printed Materials

- ▶ Why Leap (S11014)
- ▶ Leap Brochure (03-0003669)
- ▶ Leap Overview Positioning Piece (S11016)
- ▶ Leap White Paper Packets (S11019)
- ▶ Work Effectiveness Study White Papers (02-0001642)
- ▶ Leap Quick Reference Pocket Card (S11042)
- ▶ Leap User Guide (S11236)
- ▶ Seating Overview (03-0003368)

Computer Tools

- ▶ Interactive User Guide available on www.steelcase.com
- ▶ Electronic User Disk (S2305)—Windows
- ▶ Leap CD-ROM (S11015)

Dimensions

Leap 462 Series

Features	Overall Depth	Width	Height	Seat Depth	Functional Seat Depth	Seat Width	Seat Height from Floor	Back Width	Back Height from Seat	Back Lumbar Height
Leap 462 Series										
High-Back Work Chairs										
Adjustable Seat Depth	21 ³ / ₄ " to 24 ³ / ₄ "	29 ¹ / ₄ "	40" to 45"	19"	15 ¹ / ₄ " to 18 ¹ / ₄ "	20"	15" to 20"	19"	26"	5 ¹ / ₄ " to 10 ¹ / ₄ "
Fixed Seat Depth	23 ³ / ₄ "	29 ¹ / ₄ "	40" to 45"	19"	16 ¹ / ₄ "	20"	15" to 20"	19"	26"	5 ¹ / ₄ " to 10 ¹ / ₄ "
Full-Back Work Chairs										
Adjustable Seat Depth	21 ³ / ₄ " to 24 ³ / ₄ "	29 ¹ / ₄ "	37" to 42"	19"	15 ¹ / ₄ " to 18 ¹ / ₄ "	20"	15" to 20"	19"	23"	5 ¹ / ₄ " to 10 ¹ / ₄ "
Fixed Seat Depth	23 ³ / ₄ "	29 ¹ / ₄ "	37" to 42"	19"	16 ¹ / ₄ "	20"	15" to 20"	19"	23"	5 ¹ / ₄ " to 10 ¹ / ₄ "
Full-Back Stools										
Adjustable Seat Depth	21 ³ / ₄ " to 24"	29 ¹ / ₄ "	42" to 50"	19"	15 ¹ / ₄ " to 17 ¹ / ₂ "	20"	22" to 30"	19"	23"	5 ¹ / ₄ " to 10 ¹ / ₄ "
Fixed Seat Depth	23 ³ / ₄ "	29 ¹ / ₄ "	42" to 50"	19"	16 ¹ / ₄ "	20"	22" to 30"	19"	23"	5 ¹ / ₄ " to 10 ¹ / ₄ "

Dimensions are identical for arch backframe and ribbon backframe chairs in standard upholstery, pillowed upholstery, and bare-back.

Functional seat depth measurements were taken with Leap's Live Back unflexed. If fully flexed, the functional seat depth measurements on the adjustable seat depth models are 14¹/₂"–19" and 16¹/₄"–17¹/₄" on the fixed seat depth models.

Dimensions were measured with BIFMA CMD.

Seat depth measurement is simply the size of the seat from front to back.

Chairs without the seat edge angle adjustment have a flexing front seat edge of approximately 1/2°.

Chairs with the seat edge angle adjustment allow the front edge of the seat to drop approximately 2°.

Arm width adjustment is 13"–19". Arm pivot adjustment adds 2³/₄" to the width providing a total of 12¹/₄"–21" of width between the arms.

Lumbar Flex Zone	Width Between Arms	Width Between Fixed Arms	Arm to Floor	Arm Height from Seat	Arm Height from Seat for Fixed Arms	Arm Cap Pivot Range	Seat Pan Angle	Angle Between Seat and Back
High-Back Work Chairs								
5 1/4" to 10 1/4"	12" to 21"	20 3/8"	22" to 32"	7" to 11"	8 4/5"	35°	-6° to 3°	99° to 118°
5 1/4" to 10 1/4"	12" to 21"	20 3/8"	22" to 32"	7" to 11"	8 4/5"	35°	0° to 3°	99° to 118°
Full-Back Work Chairs								
5 1/4" to 10 1/4"	12" to 21"	20 3/8"	22" to 32"	7" to 11"	8 4/5"	35°	-6° to 3°	99° to 118°
5 1/4" to 10 1/4"	12" to 21"	20 3/8"	22" to 32"	7" to 11"	8 4/5"	35°	0° to 3°	99° to 118°
Full-Back Stools								
5 1/4" to 10 1/4"	12" to 21"	20 3/8"	28" to 40"	7" to 11"	8 4/5"	35°	-6° to 3°	99° to 118°
5 1/4" to 10 1/4"	12" to 21"	20 3/8"	28" to 40"	7" to 11"	8 4/5"	35°	0° to 3°	99° to 118°

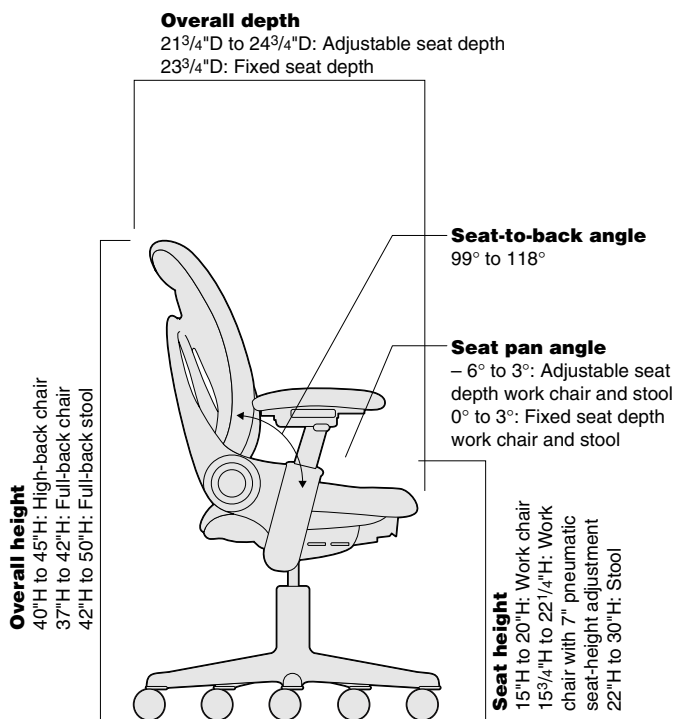
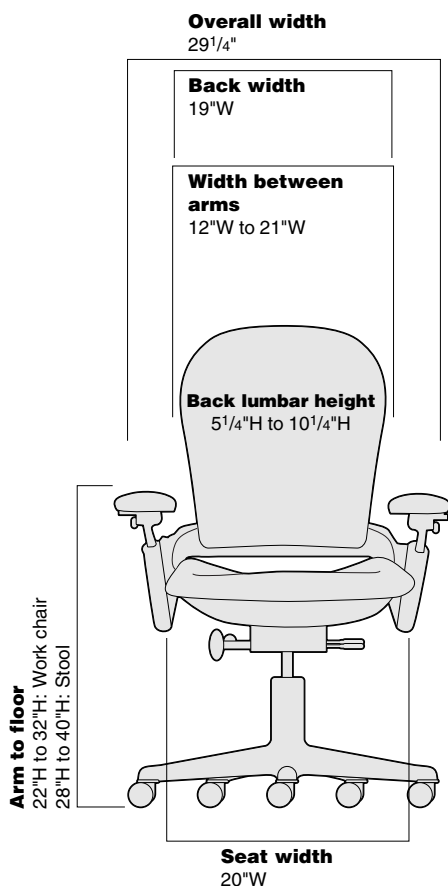

Leap 462 Series Value Package Work Chairs

Ribbon Backframe
Standard Upholstery



Tip: Value package models are available with surface material options only.

Tip: When specifying Designtex Graded-In or COM fabric, you must use value package 2 or 4.

Standard Includes		Required to Specify
<ul style="list-style-type: none"> ▶ Need help? Product details, page 22 	<ul style="list-style-type: none"> • Upper back force • 5" pneumatic seat-height adjustment • Variable back stop • Lower back firmness • Rectilinear independent height-, width-, and pivot-adjustable arms: black plastic • 3" adjustable seat depth and seat edge angle • Frame, seat shell, outer back, and five-arm base: plastic • Standard upholstery design: fabric price group 1 • 3"-diameter, hard-composition, dual-wheel casters: black • 5" travel for lumbar support 	<ol style="list-style-type: none"> 1 Style number 2 Plastic color for frame, outer back, and base 3 Fabric color number for upholstery on seat and back 4 Options, if selected (see below) <p>▶ See <i>Surface Materials</i>, page 282.</p>

Options	U.S. Price	Required to Specify
<p>Surface Materials</p> <p>Upholstery</p> <ul style="list-style-type: none"> • Fabric price group 1 • Fabric price group 2 • Fabric price group 3 • Fabric price group 4 • Fabric price group 5 • Fabric price group 6 • Fabric price group 7 • Fabric price group 8 • Fabric price group 9 • Fabric price group 10 • Customer's Own Material (COM) on sewn upholstery 	<p>No cost</p> <p>+\$ 20</p> <p>+\$ 40</p> <p>+\$ 55</p> <p>+\$ 70</p> <p>+\$ 85</p> <p>+\$100</p> <p>+\$125</p> <p>+\$155</p> <p>+\$175</p> <p>No cost</p>	<p>Specify fabric color number.</p> <p>Specify fabric color number.</p> <p>Specify fabric color number.</p> <p>Specify fabric color number.</p> <p>Specify fabric color number.</p> <p>Specify fabric color number.</p> <p>Specify fabric color number.</p> <p>Specify fabric color number.</p> <p>Specify fabric color number.</p> <p>Specify fabric color number.</p> <p>▶ See <i>Surface Materials Reference Manual</i> to specify.</p>



For Canadian Pricing
Multiply U.S. Price by 1.38.
▶ See page 1 for details.

Leap Value Package 1

Ribbon Backframe

Full Back

Lumbar-Height Adjustment
Steelcase Classics or Designtex Environmental
Impact Collection Fabrics Only
Standard Upholstery Design



Style Number 462LEAP9L
\$1158 U.S. for Price Group 1

Leap Value Package 2

Ribbon Backframe

Full Back

Lumbar-Height Adjustment
Designtex Graded-In or COM with
Sewn Upholstery Detail
Standard Upholstery Design



Style Number 462LEAP9LX
\$1188 U.S. for COM

Leap Value Package 3

Ribbon Backframe

High Back

Lumbar-Height Adjustment
Steelcase Classics or Designtex
Environmental Impact Collection Fabrics Only
Standard Upholstery Design



Style Number 462LEAP19L
\$1208 U.S. for Price Group 1

Leap Value Package 4

Ribbon Backframe

High Back

Lumbar-Height Adjustment
Designtex Graded-In or COM with
Sewn Upholstery Detail
Standard Upholstery Design



Style Number 462LEAP19LX
\$1238 U.S. for COM

Leap 462 Series Value Package Work Chairs

Ribbon Backframe
Pillowed Upholstery



Tip: Value package models are available with surface material options only.

Tip: Value package 6 (style number 462LEAPP9LX) has been eliminated. Order value package 5 instead.

Tip: Value package 8 (style number 462LEAPP19X) has been eliminated. Order value package 7 instead.

Tip: Performance fabric is a default of the plastic color specified.

Standard Includes		Required to Specify
<ul style="list-style-type: none"> ▶ Need help? Product details, page 22 	<ul style="list-style-type: none"> • Upper back force • 5" pneumatic seat-height adjustment • Variable back stop • Lower back firmness • Rectilinear independent height-, width-, and pivot-adjustable arms: black plastic • 3" adjustable seat depth and seat edge angle • Frame, seat shell, outer back, and five-arm base: plastic • Pillowed upholstery design: fabric price group 1 • Performance fabric to secure back and seat pillows • 3"-diameter, hard-composition, dual-wheel casters: black 	<ol style="list-style-type: none"> 1 Style number 2 Plastic color for frame, outer back, and base 3 Fabric color number for upholstery on seat and back 4 Options, if selected (see below) <p>▶ See <i>Surface Materials</i>, page 282.</p>

Options	U.S. Price	Required to Specify
Surface Materials		
Upholstery		
<ul style="list-style-type: none"> • Fabric price group 1 • Fabric price group 2 • Fabric price group 3 • Fabric price group 4 • Fabric price group 5 • Fabric price group 6 • Fabric price group 7 • Fabric price group 8 • Fabric price group 9 • Fabric price group 10 • Customer's Own Material (COM) 	<p>No cost</p> <p>+\$ 20</p> <p>+\$ 40</p> <p>+\$ 55</p> <p>+\$ 70</p> <p>+\$ 85</p> <p>+\$100</p> <p>+\$125</p> <p>+\$155</p> <p>+\$175</p> <p>+\$ 30</p>	<p>Specify fabric color number.</p> <p>Specify fabric color number.</p> <p>Specify fabric color number.</p> <p>Specify fabric color number.</p> <p>Specify fabric color number.</p> <p>Specify fabric color number.</p> <p>Specify fabric color number.</p> <p>Specify fabric color number.</p> <p>Specify fabric color number.</p> <p>Specify fabric color number.</p> <p>▶ See <i>Surface Materials Reference Manual</i> to specify.</p>



For Canadian Pricing
Multiply U.S. Price by 1.38.
▶ See page 1 for details.

Leap Value Package 5

Ribbon Backframe

Full Back

Steelcase Classics Collection Fabrics,
DesignTex Graded-In, or COM
Pillowed Upholstery Design



Style Number 462LEAPP9L
\$1208 U.S. for Price Group 1

Leap Value Package 7

Ribbon Backframe

High Back

Steelcase Classics Collection Fabrics,
DesignTex Graded-In, or COM
Pillowed Upholstery Design



Style Number 462LEAPP19L
\$1258 U.S. for Price Group 1

Leap 462 Series Value Package Work Chairs

Arch Backframe
Standard Upholstery



Tip: Value package models are available with surface material options only.

Tip: When specifying Designtex Graded-In or COM fabric, you must use value package 10 or 12.

Standard Includes		Required to Specify
<ul style="list-style-type: none"> ▶ Need help? Product details, page 22 	<ul style="list-style-type: none"> • Upper back force • 5" pneumatic seat-height adjustment • Variable back stop • Lower back firmness • Rectilinear independent height-, width-, and pivot-adjustable arms: black plastic • 3" adjustable seat depth and seat edge angle • Frame, seat shell, outer back, and five-arm base: plastic • Standard upholstery design: fabric price group 1 • 3"-diameter, hard-composition, dual-wheel casters: black • 5" travel for additional lumbar support 	<ol style="list-style-type: none"> 1 Style number 2 Plastic color for frame, outer back, and base 3 Fabric color number for upholstery on seat and back 4 Options, if selected (see below) <p>▶ See <i>Surface Materials</i>, page 282.</p>

Options	U.S. Price	Required to Specify
<p>Surface Materials</p> <p>Upholstery</p> <ul style="list-style-type: none"> • Fabric price group 1 • Fabric price group 2 • Fabric price group 3 • Fabric price group 4 • Fabric price group 5 • Fabric price group 6 • Fabric price group 7 • Fabric price group 8 • Fabric price group 9 • Fabric price group 10 • Customer's Own Material (COM) on sewn upholstery 	<p>No cost</p> <p>+\$ 20</p> <p>+\$ 40</p> <p>+\$ 55</p> <p>+\$ 70</p> <p>+\$ 85</p> <p>+\$100</p> <p>+\$125</p> <p>+\$155</p> <p>+\$175</p> <p>No cost</p>	<p>Specify fabric color number.</p> <p>Specify fabric color number.</p> <p>Specify fabric color number.</p> <p>Specify fabric color number.</p> <p>Specify fabric color number.</p> <p>Specify fabric color number.</p> <p>Specify fabric color number.</p> <p>Specify fabric color number.</p> <p>Specify fabric color number.</p> <p>Specify fabric color number.</p> <p>▶ See <i>Surface Materials Reference Manual</i> to specify.</p>



For Canadian Pricing
Multiply U.S. Price by 1.38.
▶ See page 1 for details.

Leap Value Package 9

Arch Backframe

Full Back

Lumbar-Height Adjustment
Steelcase Classics or Designtex Environmental
Impact Collection Fabrics Only
Standard Upholstery Design



Style Number 462LEAPL
\$1198 U.S. for Price Group 1

Leap Value Package 10

Arch Backframe

Full Back

Lumbar-Height Adjustment
Designtex Graded-In or COM
with Sewn Upholstery Detail
Standard Upholstery Design



Style Number 462LEAPLX
\$1228 U.S. for COM

Leap Value Package 11

Arch Backframe

High Back

Lumbar-Height Adjustment
Steelcase Classics or Designtex Environmental
Impact Collection Fabrics Only
Standard Upholstery Design



Style Number 462LEAP1L
\$1248 U.S. for Price Group 1

Leap Value Package 12

Arch Backframe

High Back

Lumbar-Height Adjustment
Designtex Graded-In or COM
with Sewn Upholstery Detail
Standard Upholstery Design



Style Number 462LEAP1LX
\$1278 U.S. for COM

Leap 462 Series Coach Edition Leather Work Chairs

Ribbon Backframe

Pillowed Upholstery on Back and Standard Upholstery on Seat



Tip: Coach leather upholstery is available with matching or contrasting thread stitching. Separate finish numbers are used to specify each.

Standard Includes		Required to Specify
<ul style="list-style-type: none"> ▶ Need help? Product details, page 22 	<ul style="list-style-type: none"> Pillowed upholstery back and standard upholstery seat: Coach leather Upper back force 5" pneumatic seat-height adjustment Variable back stop Lower back firmness Flexing front edge seat Independent height-, width-, and pivot-adjustable arms and see-through arm caps: black plastic only Seat shell and outer back: black plastic only Polished aluminum package on ribbon backframe, arm tube, five-arm base, and casters On adjustable seat models: 3" seat depth adjustment and seat edge angle adjustment 3"-diameter, hard-composition, dual-wheel casters: black with polished aluminum 	<ul style="list-style-type: none"> 1 Style number 2 Coach leather color number (with matching or contrasting thread stitching) for back and seat 3 Options, if selected (see below) <ul style="list-style-type: none"> ▶ See <i>Surface Materials</i>, page 282.

Options	U.S. Price	Required to Specify
Seat Depth <ul style="list-style-type: none"> 3" seat depth adjustment: available on adjustable seat models only 	-\$50	Specify with seat depth adjustment only.
Casters <ul style="list-style-type: none"> Soft, dual-wheel casters for use on hard floors 	+\$18	Specify with soft casters.

Specification Information

Blecker
High-Back with Height-, Width-, and Pivot-Adjustable Arms



• Style Number
• U.S. Base Price

Mercer
High-Back with Height-, Width-, and Pivot-Adjustable Arms



• Style Number
• U.S. Base Price

Without Adjustable Seat (No Seat Depth or Seat Edge Angle)			
462COACH1	\$2250	462COACH3	\$2250
With Adjustable Seat (Seat Depth and Seat Edge Angle)			
462COACH2	\$2400	462COACH4	\$2400



For Canadian Pricing
Multiply U.S. Price by 1.38.
▶ See page 1 for details.



For Canadian Pricing
Multiply U.S. Price by 1.38.
▶ See page 1 for details.

Leap 462 Series Work Chairs

Ribbon Backframe

Standard Upholstery on Back and Seat



Standard Includes	Required to Specify
<ul style="list-style-type: none"> ▶ Need help? Product details, page 22 • Upper back force • 5" pneumatic seat-height adjustment • Variable back stop • Lower back firmness • Flexing front edge seat • Rectilinear independent height-, width-, and pivot-adjustable arms and soft arm caps, if selected: black plastic • Frame, seat shell, outer back, and five-arm base: plastic • On adjustable seat models: 3" seat depth adjustment and seat edge angle adjustment • Standard upholstery design: fabric price group 1 • 3"-diameter, hard-composition, dual-wheel casters: black 	<ol style="list-style-type: none"> 1 Style number 2 Plastic color for frame, seat shell, outer back, and base 3 Fabric color number for upholstery on seat and back 4 Options, if selected (see below) <ul style="list-style-type: none"> ▶ See <i>Surface Materials</i>, page 282.

Surface Materials	Options	U.S. Price	Required to Specify
	Upholstery <ul style="list-style-type: none"> • Fabric price group 1 • Fabric price group 2 • Fabric price group 3 • Fabric price group 4 • Fabric price group 5 • Fabric price group 6 • Fabric price group 7 • Fabric price group 8 • Fabric price group 9 • Fabric price group 10 • Customer's Own Material (COM) or Designtex Graded-In • Steelcase leather upholstery • Steelcase vinyl • Customer's Own Leather (COL) or Customer's Own Vinyl (COV) • Fire Code Seating (FCS) • Soil-retardant treatment applied to upholstery fabric 	<ul style="list-style-type: none"> No cost +\$ 20 +\$ 40 +\$ 55 +\$ 70 +\$ 85 +\$100 +\$125 +\$155 +\$175 +\$ 30 +\$590 +\$299 +\$299 +\$ 50 +\$ 17 	<ul style="list-style-type: none"> Specify fabric color number. Specify fabric color number. Specify fabric color number. Specify fabric color number. Specify fabric color number. Specify fabric color number. Specify fabric color number. Specify fabric color number. Specify fabric color number. Specify fabric color number. Add suffix X to the style number. ▶ See <i>Surface Materials Reference Manual</i>. Add suffix S to the style number and specify leather color number. Add suffix S to the style number and specify vinyl color number. Add suffix S to the style number and specify leather or vinyl color number. ▶ See <i>Surface Materials Reference Manual</i>. Add suffix F to the style number. Specify <i>with soil-retardant treatment</i>.
	Polished aluminum package <ul style="list-style-type: none"> • Polished aluminum package on chairs with arms and 6205 Black frame finish <i>Not available with 7" pneumatic seat-height adjustment.</i> 	<ul style="list-style-type: none"> +\$400 	<ul style="list-style-type: none"> Add suffix C to the style number.
	Stitched Edge Detail <ul style="list-style-type: none"> • Steelcase Classics Collection fabrics with stitched edge detail on back only 	<ul style="list-style-type: none"> +\$ 30 	<ul style="list-style-type: none"> Add suffix X to the style number.
	Fixed-Height Arms <ul style="list-style-type: none"> • Rectilinear soft arm caps • Rectilinear upholstered arm caps 	<ul style="list-style-type: none"> -\$125 -\$ 85 	<ul style="list-style-type: none"> Specify <i>with rectilinear fixed soft arms</i>. Specify <i>with rectilinear fixed upholstered arms</i>.
	Independent Height-, Width-, and Pivot-Adjustable Arms <ul style="list-style-type: none"> • Rectilinear upholstered arm caps 	<ul style="list-style-type: none"> +\$ 40 	<ul style="list-style-type: none"> Specify <i>with rectilinear height-, width-, and pivot-adjustable upholstered arms</i>.

Tip: Use an **X** suffix when specifying COM or Designtex Graded-In. There is a \$30 U.S. upcharge plus the cost of the fabric price group selected.

Tip: The Designtex Environmental Impact collection does not require an **X** suffix unless the sewn upholstery detail is desired.

Tip: Always add suffixes in alphabetical order when specifying options to Leap seating.

Tip: Fire Code Seating (FCS) option is available with certain upholstery fabric choices only.
▶ Page 289

▶ Options continued on next page

▶ Detailed dimensions, page 26



For Canadian Pricing
Multiply U.S. Price by 1.38.
▶ See page 1 for details.

► Options, continued

Options	U.S. Price	Required to Specify
Seat Height	• 7" pneumatic seat-height adjustment Not available with polished aluminum package.	+\$ 35 Specify with 7" pneumatic seat-height adjustment.
Seat Depth	• 3" seat depth adjustment: available on adjustable seat models only	-\$ 50 Specify with seat depth adjustment only.
Lumbar Height	• 5" travel for additional lumbar support	+\$ 50 Specify with adjustable lumbar height.
Casters	• Soft, dual-wheel casters for use on hard floors	+\$ 18 Specify with soft casters.

Specification Information

Full-Back
with Height-, Width-, and Pivot-Adjustable Arms



• Style Number
• U.S. Base Price

Full-Back
without Arms



• Style Number
• U.S. Base Price

Without Adjustable Seat (No Seat Depth or Seat Edge Angle)

46211109	\$ 988	46211009	\$763
-----------------	--------	-----------------	-------

With Adjustable Seat (Seat Depth and Seat Edge Angle)

46212109	\$1138	46212009	\$913
-----------------	--------	-----------------	-------

High-Back
with Height-, Width-, and Pivot-Adjustable Arms



• Style Number
• U.S. Base Price

High-Back
without Arms



• Style Number
• U.S. Base Price

Without Adjustable Seat (No Seat Depth or Seat Edge Angle)

46211119	\$1038	46211019	\$813
-----------------	--------	-----------------	-------

With Adjustable Seat (Seat Depth and Seat Edge Angle)

46212119	\$1188	46212019	\$963
-----------------	--------	-----------------	-------



For Canadian Pricing
Multiply U.S. Price by 1.38.
► See page 1 for details.

Leap 462 Series Work Chairs

Ribbon Backframe

Pillowed Upholstery on Back and Seat



Standard Includes		Required to Specify
<ul style="list-style-type: none"> ▶ Need help? Product details, page 22 	<ul style="list-style-type: none"> • Upper back force • 5" pneumatic seat-height adjustment • Variable back stop • Lower back firmness • Flexing front edge seat • Rectilinear independent height-, width-, and pivot-adjustable arms and soft arm caps, if selected: black plastic • Frame, seat shell, outer back, and five-arm base: plastic • On adjustable seat models: 3" seat depth adjustment and seat edge angle adjustment • Pillowed upholstery design: fabric price group 1 • Performance fabric to secure back and seat pillows • 3"-diameter, hard-composition, dual-wheel casters: black 	<ol style="list-style-type: none"> 1 Style number 2 Plastic color for frame, seat shell, outer back, and base 3 Fabric color number for upholstery on seat and back 4 Options, if selected (see below) <ul style="list-style-type: none"> ▶ See <i>Surface Materials</i>, page 282.

	Options	U.S. Price	Required to Specify
Surface Materials	Upholstery		
	• Fabric price group 1	No cost	Specify fabric color number.
	• Fabric price group 2	+\$ 20	Specify fabric color number.
	• Fabric price group 3	+\$ 40	Specify fabric color number.
	• Fabric price group 4	+\$ 55	Specify fabric color number.
	• Fabric price group 5	+\$ 70	Specify fabric color number.
	• Fabric price group 6	+\$ 85	Specify fabric color number.
	• Fabric price group 7	+\$100	Specify fabric color number.
	• Fabric price group 8	+\$125	Specify fabric color number.
	• Fabric price group 9	+\$155	Specify fabric color number.
• Fabric price group 10	+\$175	Specify fabric color number.	
• Customer's Own Material (COM)	+\$ 30	▶ See <i>Surface Materials Reference Manual</i> to specify.	
	• Steelcase leather upholstery	+\$250	Add suffix S to the style number and specify leather color number.
	• Steelcase vinyl	No cost	Add suffix S to the style number and specify vinyl color number.
	• Coach leather (without pattern)	+\$400	Add suffix Y to the style number and specify coach leather color number.
	• Customer's Own Leather (COL) or Customer's Own Vinyl (COV)	+\$100	Add suffix S to the style number and specify leather or vinyl color number.
	• Fire Code Seating (FCS)	+\$ 50	▶ See <i>Surface Materials Reference Manual</i> . Add suffix F to the style number.
	• Soil-retardant treatment applied to upholstery fabric	+\$ 17	Specify <i>with soil-retardant treatment</i> .
	Polished aluminum package		
	• Polished aluminum package on chairs with arms and 6205 Black frame finish <i>Not available with 7" pneumatic seat-height adjustment.</i>	+\$400	Add suffix C to the style number.
Fixed-Height Arms	• Rectilinear soft arm caps	-\$125	Specify <i>with rectilinear fixed soft arms</i> .
	• Rectilinear upholstered arm caps	-\$ 85	Specify <i>with rectilinear fixed upholstered arms</i> .
Independent Height-, Width-, and Pivot-Adjustable Arms	• Rectilinear upholstered arm caps	+\$ 40	Specify <i>with rectilinear height-, width-, and pivot-adjustable upholstered arms</i> .
Seat Height	• 7" pneumatic seat-height adjustment <i>Not available with polished aluminum package.</i>	+\$ 35	Specify <i>with 7" pneumatic seat-height adjustment</i> .
Seat Depth	• 3" seat depth adjustment: available on adjustable seat models only	-\$ 50	Specify <i>with seat depth adjustment only</i> .

Tip: Always add suffixes in alphabetical order when specifying options to Leap seating.

Tip: Fire Code Seating (FCS) option is available with certain upholstery fabric choices only.

▶ Page 289

▶ Detailed dimensions, page 26



For Canadian Pricing
Multiply U.S. Price by 1.38.
▶ See page 1 for details.

▶ Options continued on next page

► Options, continued

Options	U.S. Price	Required to Specify
Casters • Soft, dual-wheel casters for use on hard floors	+\$ 18	Specify <i>with soft casters</i> .

Specification Information

Full-Back
with Height-, Width-, and Pivot-Adjustable Arms



• **Style Number**
.....
.....
.....

• **U.S. Base Price**
.....
.....
.....

Full-Back
without Arms



• **Style Number**
.....
.....
.....

• **U.S. Base Price**
.....
.....
.....

Without Adjustable Seat (No Seat Depth or Seat Edge Angle)

46213129	\$1088	46213029	\$ 863
-----------------	--------	-----------------	--------

With Adjustable Seat (Seat Depth and Seat Edge Angle)

46214129	\$1238	46214029	\$1013
-----------------	--------	-----------------	--------

High-Back
with Height-, Width-, and Pivot-Adjustable Arms



• **Style Number**
.....
.....
.....

• **U.S. Base Price**
.....
.....
.....

High-Back
without Arms



• **Style Number**
.....
.....
.....

• **U.S. Base Price**
.....
.....
.....

Without Adjustable Seat (No Seat Depth or Seat Edge Angle)

46213139	\$1138	46213039	\$ 913
-----------------	--------	-----------------	--------

With Adjustable Seat (Seat Depth and Seat Edge Angle)

46214139	\$1288	46214039	\$1063
-----------------	--------	-----------------	--------



For Canadian Pricing
Multiply U.S. Price by 1.38.
► See page 1 for details.

Leap 462 Series Work Chairs

Ribbon Backframe

Bare-Back and Standard Upholstery on Seat



Standard Includes	Required to Specify
<ul style="list-style-type: none"> ▶ Need help? Product details, page 22 • Upper back force • 5" pneumatic seat-height adjustment • Variable back stop • Lower back firmness • Flexing front edge seat • Rectilinear independent height-, width-, and pivot-adjustable arms and soft arm caps, if selected: black plastic • Frame, seat shell, back, and five-arm base: plastic • On adjustable seat models: 3" seat depth adjustment and seat edge angle adjustment • Standard upholstery design on seat: fabric price group 1 • 3"-diameter, hard-composition, dual-wheel casters: black 	<ol style="list-style-type: none"> 1 Style number 2 Plastic color for frame, seat shell, back, and base 3 Fabric color number for upholstery on seat 4 Options, if selected (see below) <ul style="list-style-type: none"> ▶ See <i>Surface Materials</i>, page 282.

Options	U.S. Price	Required to Specify												
<table border="0" style="width: 100%;"> <tr> <td style="vertical-align: top; width: 30%;">Surface Materials</td> <td style="vertical-align: top;">Upholstery</td> <td></td> </tr> <tr> <td></td> <td> <ul style="list-style-type: none"> • Fabric price group 1 • Fabric price group 2 • Fabric price group 3 • Fabric price group 4 • Fabric price group 5 • Fabric price group 6 • Fabric price group 7 • Fabric price group 8 • Fabric price group 9 • Fabric price group 10 • Customer's Own Material (COM) </td> <td> <ul style="list-style-type: none"> No cost +\$ 10 +\$ 20 +\$ 28 +\$ 35 +\$ 43 +\$ 50 +\$ 63 +\$ 78 +\$ 88 +\$ 15 </td> </tr> <tr> <td></td> <td> <ul style="list-style-type: none"> • Steelcase leather upholstery • Steelcase vinyl • Customer's Own Leather (COL) or Customer's Own Vinyl (COV) • Soil-retardant treatment applied to upholstery fabric </td> <td> <ul style="list-style-type: none"> Specify fabric color number. Specify fabric color number. Specify fabric color number. Specify fabric color number. Specify fabric color number. Specify fabric color number. Specify fabric color number. Specify fabric color number. Specify fabric color number. Specify fabric color number. ▶ See <i>Surface Materials Reference Manual</i> to specify. Add suffix S to the style number and specify leather color number. Add suffix S to the style number and specify vinyl color number. Add suffix S to the style number and specify leather or vinyl color number. ▶ See <i>Surface Materials Reference Manual</i>. Specify with soil-retardant treatment. </td> </tr> <tr> <td></td> <td> <ul style="list-style-type: none"> • Polished aluminum package </td> <td> <ul style="list-style-type: none"> +\$400 </td> </tr> </table>	Surface Materials	Upholstery			<ul style="list-style-type: none"> • Fabric price group 1 • Fabric price group 2 • Fabric price group 3 • Fabric price group 4 • Fabric price group 5 • Fabric price group 6 • Fabric price group 7 • Fabric price group 8 • Fabric price group 9 • Fabric price group 10 • Customer's Own Material (COM) 	<ul style="list-style-type: none"> No cost +\$ 10 +\$ 20 +\$ 28 +\$ 35 +\$ 43 +\$ 50 +\$ 63 +\$ 78 +\$ 88 +\$ 15 		<ul style="list-style-type: none"> • Steelcase leather upholstery • Steelcase vinyl • Customer's Own Leather (COL) or Customer's Own Vinyl (COV) • Soil-retardant treatment applied to upholstery fabric 	<ul style="list-style-type: none"> Specify fabric color number. Specify fabric color number. Specify fabric color number. Specify fabric color number. Specify fabric color number. Specify fabric color number. Specify fabric color number. Specify fabric color number. Specify fabric color number. Specify fabric color number. ▶ See <i>Surface Materials Reference Manual</i> to specify. Add suffix S to the style number and specify leather color number. Add suffix S to the style number and specify vinyl color number. Add suffix S to the style number and specify leather or vinyl color number. ▶ See <i>Surface Materials Reference Manual</i>. Specify with soil-retardant treatment. 		<ul style="list-style-type: none"> • Polished aluminum package 	<ul style="list-style-type: none"> +\$400 		
Surface Materials	Upholstery													
	<ul style="list-style-type: none"> • Fabric price group 1 • Fabric price group 2 • Fabric price group 3 • Fabric price group 4 • Fabric price group 5 • Fabric price group 6 • Fabric price group 7 • Fabric price group 8 • Fabric price group 9 • Fabric price group 10 • Customer's Own Material (COM) 	<ul style="list-style-type: none"> No cost +\$ 10 +\$ 20 +\$ 28 +\$ 35 +\$ 43 +\$ 50 +\$ 63 +\$ 78 +\$ 88 +\$ 15 												
	<ul style="list-style-type: none"> • Steelcase leather upholstery • Steelcase vinyl • Customer's Own Leather (COL) or Customer's Own Vinyl (COV) • Soil-retardant treatment applied to upholstery fabric 	<ul style="list-style-type: none"> Specify fabric color number. Specify fabric color number. Specify fabric color number. Specify fabric color number. Specify fabric color number. Specify fabric color number. Specify fabric color number. Specify fabric color number. Specify fabric color number. Specify fabric color number. ▶ See <i>Surface Materials Reference Manual</i> to specify. Add suffix S to the style number and specify leather color number. Add suffix S to the style number and specify vinyl color number. Add suffix S to the style number and specify leather or vinyl color number. ▶ See <i>Surface Materials Reference Manual</i>. Specify with soil-retardant treatment. 												
	<ul style="list-style-type: none"> • Polished aluminum package 	<ul style="list-style-type: none"> +\$400 												
<table border="0" style="width: 100%;"> <tr> <td style="vertical-align: top; width: 30%;">Fixed-Height Arms</td> <td style="vertical-align: top;"> <ul style="list-style-type: none"> • Rectilinear soft arm caps • Rectilinear upholstered arm caps </td> <td style="vertical-align: top;"> <ul style="list-style-type: none"> -\$125 -\$ 85 </td> <td style="vertical-align: top;"> <ul style="list-style-type: none"> Specify with <i>rectilinear fixed soft arms</i>. Specify with <i>rectilinear fixed upholstered arms</i>. </td> </tr> </table>	Fixed-Height Arms	<ul style="list-style-type: none"> • Rectilinear soft arm caps • Rectilinear upholstered arm caps 	<ul style="list-style-type: none"> -\$125 -\$ 85 	<ul style="list-style-type: none"> Specify with <i>rectilinear fixed soft arms</i>. Specify with <i>rectilinear fixed upholstered arms</i>. 										
Fixed-Height Arms	<ul style="list-style-type: none"> • Rectilinear soft arm caps • Rectilinear upholstered arm caps 	<ul style="list-style-type: none"> -\$125 -\$ 85 	<ul style="list-style-type: none"> Specify with <i>rectilinear fixed soft arms</i>. Specify with <i>rectilinear fixed upholstered arms</i>. 											
<table border="0" style="width: 100%;"> <tr> <td style="vertical-align: top; width: 30%;">Independent Height-, Width-, and Pivot-Adjustable Arms</td> <td style="vertical-align: top;"> <ul style="list-style-type: none"> • Rectilinear upholstered arm caps </td> <td style="vertical-align: top;"> <ul style="list-style-type: none"> +\$ 40 </td> <td style="vertical-align: top;"> <ul style="list-style-type: none"> Specify with <i>rectilinear height-, width-, and pivot-adjustable upholstered arms</i>. </td> </tr> </table>	Independent Height-, Width-, and Pivot-Adjustable Arms	<ul style="list-style-type: none"> • Rectilinear upholstered arm caps 	<ul style="list-style-type: none"> +\$ 40 	<ul style="list-style-type: none"> Specify with <i>rectilinear height-, width-, and pivot-adjustable upholstered arms</i>. 										
Independent Height-, Width-, and Pivot-Adjustable Arms	<ul style="list-style-type: none"> • Rectilinear upholstered arm caps 	<ul style="list-style-type: none"> +\$ 40 	<ul style="list-style-type: none"> Specify with <i>rectilinear height-, width-, and pivot-adjustable upholstered arms</i>. 											
<table border="0" style="width: 100%;"> <tr> <td style="vertical-align: top; width: 30%;">Seat Height</td> <td style="vertical-align: top;"> <ul style="list-style-type: none"> • 7" pneumatic seat-height adjustment <i>Not available with polished aluminum package.</i> </td> <td style="vertical-align: top;"> <ul style="list-style-type: none"> +\$ 35 </td> <td style="vertical-align: top;"> <ul style="list-style-type: none"> Specify with <i>7" pneumatic seat-height adjustment</i>. </td> </tr> </table>	Seat Height	<ul style="list-style-type: none"> • 7" pneumatic seat-height adjustment <i>Not available with polished aluminum package.</i> 	<ul style="list-style-type: none"> +\$ 35 	<ul style="list-style-type: none"> Specify with <i>7" pneumatic seat-height adjustment</i>. 										
Seat Height	<ul style="list-style-type: none"> • 7" pneumatic seat-height adjustment <i>Not available with polished aluminum package.</i> 	<ul style="list-style-type: none"> +\$ 35 	<ul style="list-style-type: none"> Specify with <i>7" pneumatic seat-height adjustment</i>. 											
<table border="0" style="width: 100%;"> <tr> <td style="vertical-align: top; width: 30%;">Seat Depth</td> <td style="vertical-align: top;"> <ul style="list-style-type: none"> • 3" seat depth adjustment: available on adjustable seat models only </td> <td style="vertical-align: top;"> <ul style="list-style-type: none"> -\$ 50 </td> <td style="vertical-align: top;"> <ul style="list-style-type: none"> Specify with <i>seat depth adjustment only</i>. </td> </tr> </table>	Seat Depth	<ul style="list-style-type: none"> • 3" seat depth adjustment: available on adjustable seat models only 	<ul style="list-style-type: none"> -\$ 50 	<ul style="list-style-type: none"> Specify with <i>seat depth adjustment only</i>. 										
Seat Depth	<ul style="list-style-type: none"> • 3" seat depth adjustment: available on adjustable seat models only 	<ul style="list-style-type: none"> -\$ 50 	<ul style="list-style-type: none"> Specify with <i>seat depth adjustment only</i>. 											

▶ Options continued on next page

Tip: Always add suffixes in alphabetical order when specifying options to Leap seating.

▶ Detailed dimensions, page 26



For Canadian Pricing
Multiply U.S. Price by 1.38.
▶ See page 1 for details.

► Options, continued

Options	U.S. Price	Required to Specify
Casters • Soft, dual-wheel casters for use on hard floors	+\$18	Specify <i>with soft casters</i> .
Vest • Vest for use on bare-back: 5056 Black only	+\$40	Specify <i>with vest</i> .

Specification Information

Full-Back
with Height-, Width-, and Pivot-Adjustable Arms



• Style Number
• U.S. Base Price

Full-Back
without Arms



• Style Number
• U.S. Base Price

Without Adjustable Seat (No Seat Depth or Seat Edge Angle)

46211149	\$ 988	46211049	\$763
-----------------	--------	-----------------	-------

With Adjustable Seat (Seat Depth and Seat Edge Angle)

46212149	\$1138	46212049	\$913
-----------------	--------	-----------------	-------

High-Back
with Height-, Width-, and Pivot-Adjustable Arms



• Style Number
• U.S. Base Price

High-Back
without Arms



• Style Number
• U.S. Base Price

Without Adjustable Seat (No Seat Depth or Seat Edge Angle)

46211159	\$1038	46211059	\$813
-----------------	--------	-----------------	-------

With Adjustable Seat (Seat Depth and Seat Edge Angle)

46212159	\$1188	46212059	\$963
-----------------	--------	-----------------	-------



For Canadian Pricing
Multiply U.S. Price by 1.38.
► See page 1 for details.

Leap 462 Series Work Chairs

Ribbon Backframe

Bare-Back and Pillowed Upholstery on Seat



► Need help?
Product details,
page 22

Standard Includes

- Upper back force
- 5" pneumatic seat-height adjustment
- Variable back stop
- Lower back firmness
- Flexing front edge seat
- Rectilinear independent height-, width-, and pivot-adjustable arms and soft arm caps, if selected: black plastic
- Frame, seat shell, back, and five-arm base: plastic
- On adjustable seat models: 3" seat depth adjustment and seat edge angle adjustment
- Pillowed upholstery design on seat: fabric price group 1
- Performance fabric to secure seat pillow
- 3"-diameter, hard-composition, dual-wheel casters: black

Required to Specify

- 1 Style number
 - 2 Plastic color for frame, seat shell, back, and base
 - 3 Fabric color number for upholstery on seat
 - 4 Options, if selected (see below)
- See *Surface Materials*, page 282.

Tip: Always add suffixes in alphabetical order when specifying options to Leap seating.

	Options	U.S. Price	Required to Specify
Surface Materials	Upholstery		
	• Fabric price group 1	No cost	Specify fabric color number.
	• Fabric price group 2	+\$ 10	Specify fabric color number.
	• Fabric price group 3	+\$ 20	Specify fabric color number.
	• Fabric price group 4	+\$ 28	Specify fabric color number.
	• Fabric price group 5	+\$ 35	Specify fabric color number.
	• Fabric price group 6	+\$ 43	Specify fabric color number.
	• Fabric price group 7	+\$ 50	Specify fabric color number.
	• Fabric price group 8	+\$ 63	Specify fabric color number.
	• Fabric price group 9	+\$ 78	Specify fabric color number.
• Fabric price group 10	+\$ 88	Specify fabric color number.	
• Customer's Own Material (COM)	+\$ 15	► See <i>Surface Materials Reference Manual</i> to specify.	
	• Steelcase leather upholstery	+\$125	Add suffix S to the style number and specify leather color number.
	• Steelcase vinyl	No cost	Add suffix S to the style number and specify vinyl color number.
	• Customer's Own Leather (COL) or Customer's Own Vinyl (COV)	+\$ 50	Add suffix S to the style number and specify leather or vinyl color number.
	• Soil-retardant treatment applied to upholstery fabric	+\$ 17	► See <i>Surface Materials Reference Manual</i> . Specify <i>with soil-retardant treatment</i> .
	Polished aluminum package		
	• Polished aluminum package on chairs with arms and 6205 Black frame finish <i>Not available with 7" pneumatic seat-height adjustment.</i>	+\$400	Add suffix C to the style number.
Fixed-Height Arms	• Rectilinear soft arm caps	-\$125	Specify <i>with rectilinear fixed soft arms</i> .
	• Rectilinear upholstered arm caps	-\$ 85	Specify <i>with rectilinear fixed upholstered arms..</i>
Independent Height-, Width-, and Pivot-Adjustable Arms	• Rectilinear upholstered arm caps	+\$ 40	Specify <i>with rectilinear height-, width-, and pivot-adjustable upholstered arms</i> .
Seat Height	• 7" pneumatic seat-height adjustment <i>Not available with polished aluminum package.</i>	+\$ 35	Specify <i>with 7" pneumatic seat-height adjustment</i> .
Seat Depth	• 3" seat depth adjustment: available on adjustable seat models only	-\$ 50	Specify <i>with seat depth adjustment only</i> .

► Detailed dimensions,
page 26

► Options continued on next page



For Canadian Pricing
Multiply U.S. Price by 1.38.
► See page 1 for details.

► Options, continued

Options	U.S. Price	Required to Specify
Casters • Soft, dual-wheel casters for use on hard floors	+\$18	Specify <i>with soft casters</i> .
Vest • Vest for use on bare-back: 5056 Black only	+\$40	Specify <i>with vest</i> .

Specification Information

Full-Back
with Height-, Width-, and Pivot-Adjustable Arms



• Style Number
• U.S. Base Price

Full-Back
without Arms



• Style Number
• U.S. Base Price

Without Adjustable Seat (No Seat Depth or Seat Edge Angle)

46213149	\$1038	46213049	\$ 813
-----------------	--------	-----------------	--------

With Adjustable Seat (Seat Depth and Seat Edge Angle)

46214149	\$1188	46214049	\$ 963
-----------------	--------	-----------------	--------

High-Back
with Height-, Width-, and Pivot-Adjustable Arms



• Style Number
• U.S. Base Price

High-Back
without Arms



• Style Number
• U.S. Base Price

Without Adjustable Seat (No Seat Depth or Seat Edge Angle)

46213159	\$1088	46213059	\$ 863
-----------------	--------	-----------------	--------

With Adjustable Seat (Seat Depth and Seat Edge Angle)

46214159	\$1238	46214059	\$1013
-----------------	--------	-----------------	--------



For Canadian Pricing
Multiply U.S. Price by 1.38.
► See page 1 for details.

Leap 462 Series Full-Back Stools

Ribbon Backframe

Standard Upholstery on Back and Seat



Standard Includes		Required to Specify
<ul style="list-style-type: none"> ▶ Need help? Product details, page 22 	<ul style="list-style-type: none"> • Upper back force • 8" pneumatic seat-height adjustment • Variable back stop • Lower back firmness • Flexing front edge seat • Rectilinear independent height-, width-, and pivot-adjustable arms and soft arm caps, if selected: black plastic • Frame, seat shell, outer back, and five-arm base: plastic • Adjustable foot ring 4" • On adjustable seat models: 2¼" seat depth adjustment and seat edge angle adjustment • Standard upholstery design: fabric price group 1 • 2"-diameter, hard-composition, dual-wheel casters: black 	<ol style="list-style-type: none"> 1 Style number 2 Plastic color for frame, seat shell, outer back, and base 3 Fabric color number for upholstery on seat and back 4 Options, if selected (see below) <ul style="list-style-type: none"> ▶ See <i>Surface Materials</i>, page 282.

Options	U.S. Price	Required to Specify																																																																				
<table border="1"> <thead> <tr> <th>Surface Materials</th> <th>Upholstery</th> <th>U.S. Price</th> <th>Required to Specify</th> </tr> </thead> <tbody> <tr> <td></td> <td>• Fabric price group 1</td> <td>No cost</td> <td>Specify fabric color number.</td> </tr> <tr> <td></td> <td>• Fabric price group 2</td> <td>+\$ 20</td> <td>Specify fabric color number.</td> </tr> <tr> <td></td> <td>• Fabric price group 3</td> <td>+\$ 40</td> <td>Specify fabric color number.</td> </tr> <tr> <td></td> <td>• Fabric price group 4</td> <td>+\$ 55</td> <td>Specify fabric color number.</td> </tr> <tr> <td></td> <td>• Fabric price group 5</td> <td>+\$ 70</td> <td>Specify fabric color number.</td> </tr> <tr> <td></td> <td>• Fabric price group 6</td> <td>+\$ 85</td> <td>Specify fabric color number.</td> </tr> <tr> <td></td> <td>• Fabric price group 7</td> <td>+\$100</td> <td>Specify fabric color number.</td> </tr> <tr> <td></td> <td>• Fabric price group 8</td> <td>+\$125</td> <td>Specify fabric color number.</td> </tr> <tr> <td></td> <td>• Fabric price group 9</td> <td>+\$155</td> <td>Specify fabric color number.</td> </tr> <tr> <td></td> <td>• Fabric price group 10</td> <td>+\$175</td> <td>Specify fabric color number.</td> </tr> <tr> <td></td> <td>• Customer's Own Material (COM) or Designtex Graded-in</td> <td>+\$ 30</td> <td>Add suffix X to the style number.</td> </tr> <tr> <td></td> <td>• Steelcase leather upholstery</td> <td>+\$590</td> <td>▶ See <i>Surface Materials Reference Manual</i>. Add suffix S to the style number and specify leather color number.</td> </tr> <tr> <td></td> <td>• Steelcase vinyl</td> <td>+\$299</td> <td>Add suffix S to the style number and specify vinyl color number.</td> </tr> <tr> <td></td> <td>• Customer's Own Leather (COL) or Customer's Own Vinyl (COV)</td> <td>+\$299</td> <td>Add suffix S to the style number and specify leather or vinyl color number.</td> </tr> <tr> <td></td> <td>• Fire Code Seating (FCS)</td> <td>+\$ 50</td> <td>▶ See <i>Surface Materials Reference Manual</i>. Add suffix F to the style number.</td> </tr> <tr> <td></td> <td>• Soil-retardant treatment applied to upholstery fabric</td> <td>+\$ 17</td> <td>Specify <i>with soil-retardant treatment</i>.</td> </tr> </tbody> </table>	Surface Materials	Upholstery	U.S. Price	Required to Specify		• Fabric price group 1	No cost	Specify fabric color number.		• Fabric price group 2	+\$ 20	Specify fabric color number.		• Fabric price group 3	+\$ 40	Specify fabric color number.		• Fabric price group 4	+\$ 55	Specify fabric color number.		• Fabric price group 5	+\$ 70	Specify fabric color number.		• Fabric price group 6	+\$ 85	Specify fabric color number.		• Fabric price group 7	+\$100	Specify fabric color number.		• Fabric price group 8	+\$125	Specify fabric color number.		• Fabric price group 9	+\$155	Specify fabric color number.		• Fabric price group 10	+\$175	Specify fabric color number.		• Customer's Own Material (COM) or Designtex Graded-in	+\$ 30	Add suffix X to the style number.		• Steelcase leather upholstery	+\$590	▶ See <i>Surface Materials Reference Manual</i> . Add suffix S to the style number and specify leather color number.		• Steelcase vinyl	+\$299	Add suffix S to the style number and specify vinyl color number.		• Customer's Own Leather (COL) or Customer's Own Vinyl (COV)	+\$299	Add suffix S to the style number and specify leather or vinyl color number.		• Fire Code Seating (FCS)	+\$ 50	▶ See <i>Surface Materials Reference Manual</i> . Add suffix F to the style number.		• Soil-retardant treatment applied to upholstery fabric	+\$ 17	Specify <i>with soil-retardant treatment</i> .		
Surface Materials	Upholstery	U.S. Price	Required to Specify																																																																			
	• Fabric price group 1	No cost	Specify fabric color number.																																																																			
	• Fabric price group 2	+\$ 20	Specify fabric color number.																																																																			
	• Fabric price group 3	+\$ 40	Specify fabric color number.																																																																			
	• Fabric price group 4	+\$ 55	Specify fabric color number.																																																																			
	• Fabric price group 5	+\$ 70	Specify fabric color number.																																																																			
	• Fabric price group 6	+\$ 85	Specify fabric color number.																																																																			
	• Fabric price group 7	+\$100	Specify fabric color number.																																																																			
	• Fabric price group 8	+\$125	Specify fabric color number.																																																																			
	• Fabric price group 9	+\$155	Specify fabric color number.																																																																			
	• Fabric price group 10	+\$175	Specify fabric color number.																																																																			
	• Customer's Own Material (COM) or Designtex Graded-in	+\$ 30	Add suffix X to the style number.																																																																			
	• Steelcase leather upholstery	+\$590	▶ See <i>Surface Materials Reference Manual</i> . Add suffix S to the style number and specify leather color number.																																																																			
	• Steelcase vinyl	+\$299	Add suffix S to the style number and specify vinyl color number.																																																																			
	• Customer's Own Leather (COL) or Customer's Own Vinyl (COV)	+\$299	Add suffix S to the style number and specify leather or vinyl color number.																																																																			
	• Fire Code Seating (FCS)	+\$ 50	▶ See <i>Surface Materials Reference Manual</i> . Add suffix F to the style number.																																																																			
	• Soil-retardant treatment applied to upholstery fabric	+\$ 17	Specify <i>with soil-retardant treatment</i> .																																																																			
<table border="1"> <thead> <tr> <th>Stitched Edge Detail</th> <th>Options</th> <th>U.S. Price</th> <th>Required to Specify</th> </tr> </thead> <tbody> <tr> <td></td> <td>• Steelcase Classics Collection fabrics with stitched edge detail on back only</td> <td>+\$ 30</td> <td>Add suffix X to the style number.</td> </tr> </tbody> </table>	Stitched Edge Detail	Options	U.S. Price	Required to Specify		• Steelcase Classics Collection fabrics with stitched edge detail on back only	+\$ 30	Add suffix X to the style number.																																																														
Stitched Edge Detail	Options	U.S. Price	Required to Specify																																																																			
	• Steelcase Classics Collection fabrics with stitched edge detail on back only	+\$ 30	Add suffix X to the style number.																																																																			
<table border="1"> <thead> <tr> <th>Fixed-Height Arms</th> <th>Options</th> <th>U.S. Price</th> <th>Required to Specify</th> </tr> </thead> <tbody> <tr> <td></td> <td>• Rectilinear soft arm caps</td> <td>-\$125</td> <td>Specify <i>with rectilinear fixed soft arms</i>.</td> </tr> <tr> <td></td> <td>• Rectilinear upholstered arm caps</td> <td>-\$ 85</td> <td>Specify <i>with rectilinear fixed upholstered arms</i>.</td> </tr> </tbody> </table>	Fixed-Height Arms	Options	U.S. Price	Required to Specify		• Rectilinear soft arm caps	-\$125	Specify <i>with rectilinear fixed soft arms</i> .		• Rectilinear upholstered arm caps	-\$ 85	Specify <i>with rectilinear fixed upholstered arms</i> .																																																										
Fixed-Height Arms	Options	U.S. Price	Required to Specify																																																																			
	• Rectilinear soft arm caps	-\$125	Specify <i>with rectilinear fixed soft arms</i> .																																																																			
	• Rectilinear upholstered arm caps	-\$ 85	Specify <i>with rectilinear fixed upholstered arms</i> .																																																																			
<table border="1"> <thead> <tr> <th>Independent Height-, Width-, and Pivot-Adjustable Arms</th> <th>Options</th> <th>U.S. Price</th> <th>Required to Specify</th> </tr> </thead> <tbody> <tr> <td></td> <td>• Rectilinear upholstered arm caps</td> <td>+\$ 40</td> <td>Specify <i>with rectilinear height-, width-, and pivot-adjustable upholstered arms</i>.</td> </tr> </tbody> </table>	Independent Height-, Width-, and Pivot-Adjustable Arms	Options	U.S. Price	Required to Specify		• Rectilinear upholstered arm caps	+\$ 40	Specify <i>with rectilinear height-, width-, and pivot-adjustable upholstered arms</i> .																																																														
Independent Height-, Width-, and Pivot-Adjustable Arms	Options	U.S. Price	Required to Specify																																																																			
	• Rectilinear upholstered arm caps	+\$ 40	Specify <i>with rectilinear height-, width-, and pivot-adjustable upholstered arms</i> .																																																																			
<table border="1"> <thead> <tr> <th>Seat Depth</th> <th>Options</th> <th>U.S. Price</th> <th>Required to Specify</th> </tr> </thead> <tbody> <tr> <td></td> <td>• 2¼" seat depth adjustment: available on adjustable seat models only</td> <td>-\$ 50</td> <td>Specify <i>with seat depth adjustment only</i>.</td> </tr> </tbody> </table>	Seat Depth	Options	U.S. Price	Required to Specify		• 2¼" seat depth adjustment: available on adjustable seat models only	-\$ 50	Specify <i>with seat depth adjustment only</i> .																																																														
Seat Depth	Options	U.S. Price	Required to Specify																																																																			
	• 2¼" seat depth adjustment: available on adjustable seat models only	-\$ 50	Specify <i>with seat depth adjustment only</i> .																																																																			
<table border="1"> <thead> <tr> <th>Lumbar Height</th> <th>Options</th> <th>U.S. Price</th> <th>Required to Specify</th> </tr> </thead> <tbody> <tr> <td></td> <td>• 5" travel for additional lumbar support</td> <td>+\$50</td> <td>Specify <i>with adjustable lumbar height</i>.</td> </tr> </tbody> </table>	Lumbar Height	Options	U.S. Price	Required to Specify		• 5" travel for additional lumbar support	+\$50	Specify <i>with adjustable lumbar height</i> .																																																														
Lumbar Height	Options	U.S. Price	Required to Specify																																																																			
	• 5" travel for additional lumbar support	+\$50	Specify <i>with adjustable lumbar height</i> .																																																																			
<table border="1"> <thead> <tr> <th>Casters</th> <th>Options</th> <th>U.S. Price</th> <th>Required to Specify</th> </tr> </thead> <tbody> <tr> <td></td> <td>• Soft, dual-wheel casters for use on hard floors</td> <td>+\$18</td> <td>Specify <i>with soft casters</i>.</td> </tr> </tbody> </table>	Casters	Options	U.S. Price	Required to Specify		• Soft, dual-wheel casters for use on hard floors	+\$18	Specify <i>with soft casters</i> .																																																														
Casters	Options	U.S. Price	Required to Specify																																																																			
	• Soft, dual-wheel casters for use on hard floors	+\$18	Specify <i>with soft casters</i> .																																																																			

Tip: Use an **X** suffix when specifying COM or Designtex Graded-In. There is a \$30 U.S. upcharge plus the cost of the fabric price group selected.

Tip: The Designtex Environmental Impact collection does not require an **X** suffix unless the sewn upholstery detail is desired.

Tip: Always add suffixes in alphabetical order when specifying options to Leap seating.

Tip: Fire Code Seating (FCS) option is available with certain upholstery fabric choices only.

▶ Pages 289–290

▶ Detailed dimensions, page 26



For Canadian Pricing
Multiply U.S. Price by 1.38.
▶ See page 1 for details.

Specification Information

Full-Back
with Height-, Width-, and Pivot-
Adjustable Arms



Full-Back
without Arms



• **Style
Number**

• **U.S.
Base
Price**

• **Style
Number**

• **U.S.
Base
Price**

Without Adjustable Seat (No Seat Depth or Seat Edge Angle)

46271109

\$1175

46271009

\$ 950

With Adjustable Seat (Seat Depth and Seat Edge Angle)

46272109

\$1325

46272009

\$1100



For Canadian Pricing
Multiply U.S. Price by 1.38.
▶ See page 1 for details.

Leap 462 Series Full-Back Stools

Ribbon Backframe

Pillowed Upholstery on Back and Seat



	Standard Includes	Required to Specify
▶ Need help? Product details, page 22	<ul style="list-style-type: none"> • Upper back force • 8" pneumatic seat-height adjustment • Variable back stop • Lower back firmness • Flexing front edge seat • Rectilinear independent height-, width-, and pivot-adjustable arms and soft arm caps, if selected: black plastic • Frame, seat shell, outer back, and five-arm base: plastic • Adjustable foot ring 4" • On adjustable seat models: 2¼" seat depth adjustment and seat edge angle adjustment • Pillowed upholstery design: fabric price group 1 • Performance fabric to secure back and seat pillows • 2"-diameter, hard-composition, dual-wheel casters: black 	<ol style="list-style-type: none"> 1 Style number 2 Plastic color for frame, seat shell, outer back, and base 3 Fabric color number for upholstery on seat and back 4 Options, if selected (see below) <p>▶ See <i>Surface Materials</i>, page 282.</p>

	Options	U.S. Price	Required to Specify
Surface Materials	Upholstery <ul style="list-style-type: none"> • Fabric price group 1 • Fabric price group 2 • Fabric price group 3 • Fabric price group 4 • Fabric price group 5 • Fabric price group 6 • Fabric price group 7 • Fabric price group 8 • Fabric price group 9 • Fabric price group 10 • Customer's Own Material (COM) <ul style="list-style-type: none"> • Steelcase leather upholstery • Steelcase vinyl • Coach leather (without pattern) • Customer's Own Leather (COL) or Customer's Own Vinyl (COV) • Fire Code Seating (FCS) • Soil-retardant treatment applied to upholstery fabric 	<ul style="list-style-type: none"> No cost +\$ 20 +\$ 40 +\$ 55 +\$ 70 +\$ 85 +\$100 +\$125 +\$155 +\$175 +\$ 30 +\$250 No cost +\$400 +\$100 +\$ 50 +\$ 17 	<ul style="list-style-type: none"> Specify fabric color number. Specify fabric color number. Specify fabric color number. Specify fabric color number. Specify fabric color number. Specify fabric color number. Specify fabric color number. Specify fabric color number. Specify fabric color number. Specify fabric color number. ▶ See <i>Surface Materials Reference Manual</i> to specify. Add suffix S to the style number and specify leather color number. Add suffix S to the style number and specify vinyl color number. Add suffix Y to the style number and specify coach leather color number. Add suffix S to the style number and specify leather or vinyl color number. ▶ See <i>Surface Materials Reference Manual</i>. Add suffix F to the style number. Specify <i>with soil-retardant treatment</i>.
Fixed-Height Arms	<ul style="list-style-type: none"> • Rectilinear soft arm caps • Rectilinear upholstered arm caps 	<ul style="list-style-type: none"> -\$125 -\$ 85 	<ul style="list-style-type: none"> Specify <i>with rectilinear fixed soft arms</i>. Specify <i>with rectilinear fixed upholstered arms</i>.
Independent Height-, Width-, and Pivot-Adjustable Arms	<ul style="list-style-type: none"> • Rectilinear upholstered arm caps 	<ul style="list-style-type: none"> +\$ 40 	<ul style="list-style-type: none"> Specify <i>with rectilinear height-, width-, and pivot-adjustable upholstered arms</i>.
Seat Depth	<ul style="list-style-type: none"> • 2¼" seat depth adjustment: available on adjustable seat models only 	<ul style="list-style-type: none"> -\$ 50 	<ul style="list-style-type: none"> Specify <i>with seat depth adjustment only</i>.
Casters	<ul style="list-style-type: none"> • Soft, dual-wheel casters for use on hard floors 	<ul style="list-style-type: none"> +\$18 	<ul style="list-style-type: none"> Specify <i>with soft casters</i>.

Tip: Always add suffixes in alphabetical order when specifying options to Leap seating.

Tip: Fire Code Seating (FCS) option is available with certain upholstery fabric choices only.

▶ Pages 289–290

▶ Detailed dimensions, page 26



For Canadian Pricing
Multiply U.S. Price by 1.38.
▶ See page 1 for details.

Specification Information

Full-Back
with Height-, Width-, and Pivot-
Adjustable Arms



Full-Back
without Arms



• **Style
Number**

• **U.S.
Base
Price**

• **Style
Number**

• **U.S.
Price**

Without Adjustable Seat (No Seat Depth or Seat Edge Angle)

46273129 \$1275

46273029 \$1050

With Adjustable Seat (Seat Depth and Seat Edge Angle)

46274129 \$1425

46274029 \$1200



For Canadian Pricing
Multiply U.S. Price by 1.38.
▶ See page 1 for details.

Leap 462 Series Full-Back Stools

Ribbon Backframe

Bare-Back and Standard Upholstery on Seat



Standard Includes	Required to Specify
<ul style="list-style-type: none"> ▶ Need help? Product details, page 22 • Upper back force • 8" pneumatic seat-height adjustment • Variable back stop • Lower back firmness • Flexing front edge seat • Rectilinear independent height-, width-, and pivot-adjustable arms and soft arm caps, if selected: black plastic • Frame, seat shell, back, and five-arm base: plastic • Adjustable foot ring 4" • On adjustable seat models: 2¼" seat depth adjustment and seat edge angle adjustment • Standard upholstery design on seat: fabric price group 1 • 2"-diameter, hard-composition, dual-wheel casters: black 	<ol style="list-style-type: none"> 1 Style number 2 Plastic color for frame, seat shell, back, and base 3 Fabric color number for upholstery on seat 4 Options, if selected (see below) <p>▶ See <i>Surface Materials</i>, page 282.</p>

Tip: Always add suffixes in alphabetical order when specifying options to Leap seating.

Options	U.S. Price	Required to Specify
<p>Surface Materials</p> <p>Upholstery</p> <ul style="list-style-type: none"> • Fabric price group 1 • Fabric price group 2 • Fabric price group 3 • Fabric price group 4 • Fabric price group 5 • Fabric price group 6 • Fabric price group 7 • Fabric price group 8 • Fabric price group 9 • Fabric price group 10 • Customer's Own Material (COM) <ul style="list-style-type: none"> • Steelcase leather upholstery • Steelcase vinyl • Customer's Own Leather (COL) or Customer's Own Vinyl (COV) • Soil-retardant treatment applied to upholstery fabric 	<p>No cost</p> <p>+\$ 10</p> <p>+\$ 20</p> <p>+\$ 28</p> <p>+\$ 35</p> <p>+\$ 43</p> <p>+\$ 50</p> <p>+\$ 63</p> <p>+\$ 78</p> <p>+\$ 88</p> <p>+\$ 15</p> <p>+\$300</p> <p>+\$155</p> <p>+\$155</p> <p>+\$ 17</p>	<p>Specify fabric color number.</p> <p>Specify fabric color number.</p> <p>Specify fabric color number.</p> <p>Specify fabric color number.</p> <p>Specify fabric color number.</p> <p>Specify fabric color number.</p> <p>Specify fabric color number.</p> <p>Specify fabric color number.</p> <p>Specify fabric color number.</p> <p>Specify fabric color number.</p> <p>▶ See <i>Surface Materials Reference Manual</i> to specify.</p> <p>Add suffix S to the style number and specify leather color number.</p> <p>Add suffix S to the style number and specify vinyl color number.</p> <p>Add suffix S to the style number and specify leather or vinyl color number.</p> <p>▶ See <i>Surface Materials Reference Manual</i>. Specify <i>with soil-retardant treatment</i>.</p>
<p>Fixed-Height Arms</p> <ul style="list-style-type: none"> • Rectilinear soft arm caps • Rectilinear upholstered arm caps 	<p>-\$125</p> <p>-\$ 85</p>	<p>Specify <i>with rectilinear fixed soft arms</i>.</p> <p>Specify <i>with rectilinear fixed upholstered arms</i>.</p>
<p>Independent Height-, Width-, and Pivot-Adjustable Arms</p> <ul style="list-style-type: none"> • Rectilinear upholstered arm caps 	<p>+\$ 40</p>	<p>Specify <i>with rectilinear height-, width-, and pivot-adjustable upholstered arms</i>.</p>
<p>Seat Depth</p> <ul style="list-style-type: none"> • 2¼" seat depth adjustment: available on adjustable seat models only 	<p>-\$ 50</p>	<p>Specify <i>with seat depth adjustment only</i>.</p>
<p>Casters</p> <ul style="list-style-type: none"> • Soft, dual-wheel casters for use on hard floors 	<p>+\$ 18</p>	<p>Specify <i>with soft casters</i>.</p>
<p>Vest</p> <ul style="list-style-type: none"> • Vest for use on bare-back: 5056 Black only 	<p>+\$ 40</p>	<p>Specify <i>with vest</i>.</p>

▶ Detailed dimensions, page 26



For Canadian Pricing
Multiply U.S. Price by 1.38.
▶ See page 1 for details.

Specification Information

Full-Back
with Height-, Width-, and Pivot-
Adjustable Arms



Full-Back
without Arms



• **Style
Number**

• **U.S.
Base
Price**

• **Style
Number**

• **U.S.
Base**

Without Adjustable Seat (No Seat Depth or Seat Edge Angle)

46271149	\$1175	46271049	\$ 950
-----------------	--------	-----------------	--------

With Adjustable Seat (Seat Depth and Seat Edge Angle)

46272149	\$1325	46272049	\$1100
-----------------	--------	-----------------	--------



For Canadian Pricing
Multiply U.S. Price by 1.38.
▶ See page 1 for details.

Leap 462 Series Full-Back Stools

Ribbon Backframe

Bare-Back and Pillowed Upholstery on Seat



Standard Includes		Required to Specify
<ul style="list-style-type: none"> ▶ Need help? Product details, page 22 	<ul style="list-style-type: none"> • Upper back force • 8" pneumatic seat-height adjustment • Variable back stop • Lower back firmness • Flexing front edge seat • Rectilinear independent height-, width-, and pivot-adjustable arms and soft arm caps, if selected: black plastic • Frame, seat shell, back, and five-arm base: plastic • Adjustable foot ring 4" • On adjustable seat models: 2¼" seat depth adjustment and seat edge angle adjustment • Pillowed upholstery design on seat: fabric price group 1 • Performance fabric to secure seat pillow • 2"-diameter, hard-composition, dual-wheel casters: black 	<ol style="list-style-type: none"> 1 Style number 2 Plastic color for frame, seat shell, back, and base 3 Fabric color number for upholstery on seat 4 Options, if selected (see below) <ul style="list-style-type: none"> ▶ See <i>Surface Materials</i>, page 282.

Options	U.S. Price	Required to Specify
Surface Materials <ul style="list-style-type: none"> • Upholstery <ul style="list-style-type: none"> • Fabric price group 1 • Fabric price group 2 • Fabric price group 3 • Fabric price group 4 • Fabric price group 5 • Fabric price group 6 • Fabric price group 7 • Fabric price group 8 • Fabric price group 9 • Fabric price group 10 • Customer's Own Material (COM) • Steelcase leather upholstery • Steelcase vinyl • Customer's Own Leather (COL) or Customer's Own Vinyl (COV) • Soil-retardant treatment applied to upholstery fabric 	<ul style="list-style-type: none"> No cost +\$ 10 +\$ 20 +\$ 28 +\$ 35 +\$ 43 +\$ 50 +\$ 63 +\$ 78 +\$ 88 +\$ 15 +\$125 No cost +\$ 50 +\$ 17 	<ul style="list-style-type: none"> Specify fabric color number. Specify fabric color number. Specify fabric color number. Specify fabric color number. Specify fabric color number. Specify fabric color number. Specify fabric color number. Specify fabric color number. Specify fabric color number. Specify fabric color number. Specify fabric color number. ▶ See <i>Surface Materials Reference Manual</i> to specify. Add suffix S to the style number and specify leather color number. Add suffix S to the style number and specify vinyl color number. Add suffix S to the style number and specify leather or vinyl color number. ▶ See <i>Surface Materials Reference Manual</i>. Specify <i>with soil-retardant treatment</i>.
Fixed-Height Arms <ul style="list-style-type: none"> • Rectilinear soft arm caps • Rectilinear upholstered arm caps 	<ul style="list-style-type: none"> -\$125 -\$ 85 	<ul style="list-style-type: none"> Specify <i>with rectilinear fixed soft arms</i>. Specify <i>with rectilinear fixed upholstered arms</i>.
Independent Height-, Width-, and Pivot-Adjustable Arms <ul style="list-style-type: none"> • Rectilinear upholstered arm caps 	<ul style="list-style-type: none"> +\$ 40 	<ul style="list-style-type: none"> Specify <i>with rectilinear height-, width-, and pivot-adjustable upholstered arms</i>.
Seat Depth <ul style="list-style-type: none"> • 2¼" seat depth adjustment: available on adjustable seat models only 	<ul style="list-style-type: none"> -\$ 50 	<ul style="list-style-type: none"> Specify <i>with seat depth adjustment only</i>.
Casters <ul style="list-style-type: none"> • Soft, dual-wheel casters for use on hard floors 	<ul style="list-style-type: none"> +\$18 	<ul style="list-style-type: none"> Specify <i>with soft casters</i>.
Vest <ul style="list-style-type: none"> • Vest for use on bare-back: 5056 Black only 	<ul style="list-style-type: none"> +\$40 	<ul style="list-style-type: none"> Specify <i>with vest</i>.

Tip: Always add suffixes in alphabetical order when specifying options to Leap seating.

▶ Detailed dimensions, page 26



For Canadian Pricing
Multiply U.S. Price by 1.38.
▶ See page 1 for details.

Specification Information

Full-Back
with Height-, Width-, and Pivot-
Adjustable Arms



Full-Back
without Arms



• **Style
Number**

• **U.S.
Base
Price**

• **Style
Number**

• **U.S.
Base**

Without Adjustable Seat (No Seat Depth or Seat Edge Angle)

46273149 \$1225

46273049 \$1000

With Adjustable Seat (Seat Depth and Seat Edge Angle)

46274149 \$1375

46274049 \$1150



For Canadian Pricing
Multiply U.S. Price by 1.38.
▶ See page 1 for details.

Pillowed Upholstery Packages

Pillowed Upholstery Packages for Back and Seat

for Use on Ribbon Backframe Chairs with Pillowed Upholstery Option Only

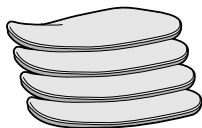
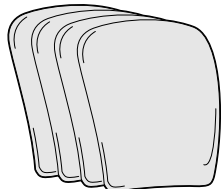

Tip: Pillow packages are sold in quantities of four. To order individual pillows, contact Customer Service Parts.

Tip: Always add suffixes in alphabetical order when specifying options to Leap seating.

Tip: To maintain FCS compliance on Leap chairs, both the original chair and the replacement seat and back cushions must be specified with the FCS option. A Leap FCS chair is identified with an FCS label on the underside of the chair.

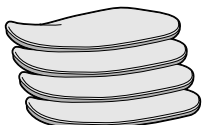
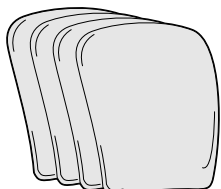

Standard Includes	Required to Specify
-------------------	---------------------

- Package of four back and four seat pillows
- Pillowed upholstery design: fabric price group 1
- Performance fabric to secure back and seat

- 1 Style number
 - 2 Fabric color number
 - 3 Plastic color number of chair (determines performance fabric color)
 - 4 Options, if selected (see below)
- ▶ See *Surface Materials*, page 282.

Surface Materials	Options	U.S. Price	Required to Specify
-------------------	---------	------------	---------------------

Surface Materials	• Fabric price group 1	No cost	Specify fabric color number.
	• Fabric price group 2	+\$ 80	Specify fabric color number.
	• Fabric price group 3	+\$ 160	Specify fabric color number.
	• Fabric price group 4	+\$ 220	Specify fabric color number.
	• Fabric price group 5	+\$ 280	Specify fabric color number.
	• Fabric price group 6	+\$ 340	Specify fabric color number.
	• Fabric price group 7	+\$ 400	Specify fabric color number.
	• Fabric price group 8	+\$ 500	Specify fabric color number.
	• Fabric price group 9	+\$ 620	Specify fabric color number.
	• Fabric price group 10	+\$ 700	Specify fabric color number.
• Customer's Own Material (COM)	+\$ 120	▶ See <i>Surface Materials Reference Manual</i> to specify.	
• Steelcase leather upholstery	+\$1000	Add suffix S to the style number and specify leather color number.	
• Steelcase vinyl	No cost	Add suffix S to the style number and specify vinyl color number.	
• Coach leather (without pattern)	+\$1600	Add suffix Y to the style number and specify coach leather color number.	
• Customer's Own Leather (COL) or Customer's Own Vinyl (COV)	+\$ 400	Add suffix S to the style number and specify leather or vinyl color number.	
• Fire Code Seating (FCS)	+\$ 50	▶ See <i>Surface Materials Reference Manual</i> . Add suffix F to the style number.	
• Soil-retardant treatment	+\$ 68	Specify <i>with soil-retardant treatment</i> .	

Specification Information			
Style Number	U.S. Base Price	Style Number	U.S. Base Price

--	--	--	--

Package of 4 Back Pillows and 4 Seat Pillows

Full-Back	High-Back
462PSTFB \$800	462PSTHB \$800

Pillowed Upholstery Packages for Back

for Use on Ribbon Backframe Chairs with Pillowed Upholstery Option Only

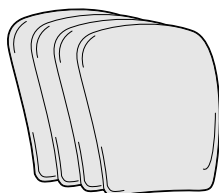

Tip: Pillow packages are sold in quantities of four. To order individual pillows, contact Customer Service Parts.

Tip: Always add suffixes in alphabetical order when specifying options to Leap seating.

Tip: To maintain FCS compliance on Leap chairs, both the original chair and the replacement seat and back cushions must be specified with the FCS option. A Leap FCS chair is identified with an FCS label on the underside of the chair.

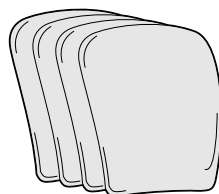

Standard Includes	Required to Specify
-------------------	---------------------

- | | |
|---|---|
| <ul style="list-style-type: none"> • Package of four back pillows • Pillowed upholstery design: fabric price group 1 • Performance fabric to secure back | <ol style="list-style-type: none"> 1 Style number 2 Fabric color number 3 Plastic color number of chair (determines performance fabric color) 4 Options, if selected (see below) <p>▶ See <i>Surface Materials</i>, page 282.</p> |
|---|---|

Options	U.S. Price	Required to Specify
---------	------------	---------------------

Surface Materials	<ul style="list-style-type: none"> • Fabric price group 1 • Fabric price group 2 • Fabric price group 3 • Fabric price group 4 • Fabric price group 5 • Fabric price group 6 • Fabric price group 7 • Fabric price group 8 • Fabric price group 9 • Fabric price group 10 • Customer's Own Material (COM) 	<ul style="list-style-type: none"> No cost +\$ 40 +\$ 80 +\$110 +\$140 +\$170 +\$200 +\$250 +\$310 +\$350 +\$ 60 	<ul style="list-style-type: none"> Specify fabric color number. Specify fabric color number. Specify fabric color number. Specify fabric color number. Specify fabric color number. Specify fabric color number. Specify fabric color number. Specify fabric color number. Specify fabric color number. Specify fabric color number. Specify fabric color number. <p>▶ See <i>Surface Materials Reference Manual</i> to specify.</p> <p>Add suffix S to the style number and specify leather color number.</p> <p>Add suffix S to the style number and specify vinyl color number.</p> <p>Add suffix S to the style number and specify leather or vinyl color number.</p> <p>▶ See <i>Surface Materials Reference Manual</i>. Add suffix F to the style number. Specify <i>with soil-retardant treatment</i>.</p>
	<ul style="list-style-type: none"> • Steelcase leather upholstery • Steelcase vinyl • Customer's Own Leather (COL) or Customer's Own Vinyl (COV) • Fire Code Seating (FCS) • Soil-retardant treatment 	<ul style="list-style-type: none"> +\$500 No cost +\$200 +\$ 50 +\$ 68 	

Specification Information

Style Number	U.S. Base Price	Style Number	U.S. Base Price

Package of 4 Back Pillows

Full-Back		High-Back	
462PFB	\$400	462PHB	\$400

For Canadian Pricing
 Multiply U.S. Price by 1.38.
 ▶ See page 1 for details.

Pillowed Upholstery Packages for Seat

for Use on Ribbon Backframe Chairs with Pillowed Upholstery Option Only



Tip: Pillow packages are sold in quantities of four. To order individual pillows, contact Customer Service Parts.

Tip: Always add suffixes in alphabetical order when specifying options to Leap seating.

Tip: To maintain FCS compliance on Leap chairs, both the original chair and the replacement seat and back cushions must be specified with the FCS option. A Leap FCS chair is identified with an FCS label on the underside of the chair.

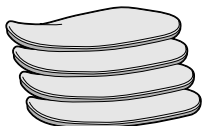

Standard Includes	Required to Specify
-------------------	---------------------

- | | |
|---|---|
| <ul style="list-style-type: none"> • Package of four seat pillows • Pillowed upholstery design: fabric price group 1 • Performance fabric to secure seat | <ol style="list-style-type: none"> 1 Style number 2 Fabric color number 3 Plastic color number of chair (determines performance fabric color) 4 Options, if selected (see below) <p>▶ See <i>Surface Materials</i>, page 282.</p> |
|---|---|

Surface Materials	Options	U.S. Price	Required to Specify
-------------------	---------	------------	---------------------

Surface Materials	• Fabric price group 1	No cost	Specify fabric color number.
	• Fabric price group 2	+\$ 40	Specify fabric color number.
	• Fabric price group 3	+\$ 80	Specify fabric color number.
	• Fabric price group 4	+\$110	Specify fabric color number.
	• Fabric price group 5	+\$140	Specify fabric color number.
	• Fabric price group 6	+\$170	Specify fabric color number.
	• Fabric price group 7	+\$200	Specify fabric color number.
	• Fabric price group 8	+\$250	Specify fabric color number.
	• Fabric price group 9	+\$310	Specify fabric color number.
	• Fabric price group 10	+\$350	Specify fabric color number.
• Customer's Own Material (COM)	+\$ 60	▶ See <i>Surface Materials Reference Manual</i> to specify.	
• Steelcase leather upholstery	+\$500	Add suffix S to the style number and specify leather color number.	
• Steelcase vinyl	No cost	Add suffix S to the style number and specify vinyl color number.	
• Customer's Own Leather (COL) or Customer's Own Vinyl (COV)	+\$200	Add suffix S to the style number and specify leather or vinyl color number.	
• Fire Code Seating (FCS)	+\$ 50	▶ See <i>Surface Materials Reference Manual</i> . Add suffix F to the style number.	
• Soil-retardant treatment	+\$ 68	Specify with soil-retardant treatment.	

Specification Information

Style Number	U.S. Base Price

Package of 4 Seat Pillows

462PST	\$400
--------	-------



For Canadian Pricing
Multiply U.S. Price by 1.38.
▶ See page 1 for details.

Vest Packages for Bare-Back

for Use on Bare-Back Ribbon Backframe Chairs

Vest Packages
for Bare-Back

Leap 462 Series

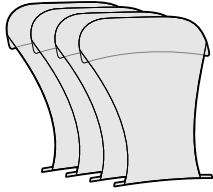

Standard Includes	Required to Specify
<ul style="list-style-type: none"> Package of four vests: 5056 Black only 	Style number

Specification Information			
Style Number	U.S. Base Price	Style Number	U.S. Base Price

Package of 4 Vests

Full-Back		High-Back	
462VFB	\$160	462VHB	\$160



For Canadian Pricing
Multiply U.S. Price by 1.38.
▶ See page 1 for details.

Leap 462 Series Work Chairs

Arch Backframe

Standard Upholstery on Back and Seat



Standard Includes		Required to Specify
<ul style="list-style-type: none"> ▶ Need help? Product details, page 22 	<ul style="list-style-type: none"> • Upper back force • 5" pneumatic seat-height adjustment • Variable back stop • Lower back firmness • Flexing front edge seat • Rectilinear independent height-, width-, and pivot-adjustable arms and soft arm caps, if selected: black plastic • Frame, seat shell, outer back, and five-arm base: plastic • On adjustable seat models: 3" seat depth adjustment and seat edge angle adjustment • Standard upholstery design: fabric price group 1 • 3"-diameter, hard-composition, dual-wheel casters: black 	<ol style="list-style-type: none"> 1 Style number 2 Plastic color for frame, seat shell, outer back, and base 3 Fabric color number for upholstery on seat 4 Options, if selected (see below) <p>▶ See <i>Surface Materials</i>, page 282.</p>

	Options	U.S. Price	Required to Specify
Surface Materials	Upholstery		
	• Fabric price group 1	No cost	Specify fabric color number.
	• Fabric price group 2	+\$ 20	Specify fabric color number.
	• Fabric price group 3	+\$ 40	Specify fabric color number.
	• Fabric price group 4	+\$ 55	Specify fabric color number.
	• Fabric price group 5	+\$ 70	Specify fabric color number.
	• Fabric price group 6	+\$ 85	Specify fabric color number.
	• Fabric price group 7	+\$100	Specify fabric color number.
	• Fabric price group 8	+\$125	Specify fabric color number.
	• Fabric price group 9	+\$155	Specify fabric color number.
• Fabric price group 10	+\$175	Specify fabric color number.	
• Customer's Own Material (COM) or Designtex Graded-In	+\$ 30	Add suffix X to the style number.	
• Steelcase leather upholstery	+\$590	▶ See <i>Surface Materials Reference Manual</i> . Add suffix S to the style number and specify leather color number.	
• Steelcase vinyl	+\$299	Add suffix S to the style number and specify vinyl color number.	
• Customer's Own Leather (COL) or Customer's Own Vinyl (COV)	+\$299	Add suffix S to the style number and specify leather or vinyl color number.	
• Fire Code Seating (FCS)	+\$ 50	▶ See <i>Surface Materials Reference Manual</i> . Add suffix F to the style number.	
• Soil-retardant treatment applied to upholstery fabric	+\$ 17	Specify with soil-retardant treatment.	
Stitched Edge Detail	• Steelcase Classics Collection fabrics with stitched edge detail on back only	+\$ 30	Add suffix X to the style number.
Fixed-Height Arms	• Rectilinear soft arm caps	-\$125	Specify with <i>rectilinear fixed soft arms</i> .
	• Rectilinear upholstered arm caps	-\$ 85	Specify with <i>rectilinear fixed upholstered arms</i> .
Independent Height-, Width-, and Pivot-Adjustable Arms	• Rectilinear upholstered arm caps	+\$ 40	Specify with <i>rectilinear height-, width-, and pivot-adjustable upholstered arms</i> .
Seat Height	• 7" pneumatic seat-height adjustment	+\$ 35	Specify with <i>7" pneumatic seat-height adjustment</i> .
Seat Depth	• 3" seat depth adjustment: available on adjustable seat models only	-\$ 50	Specify with <i>seat depth adjustment only</i> .
Lumbar Height	• 5" travel for additional lumbar support	+\$ 50	Specify with <i>adjustable lumbar height</i> .
Casters	• Soft, dual-wheel casters for use on hard floors	+\$ 18	Specify with <i>soft casters</i> .

Tip: Use an **X** suffix when specifying COM or Designtex Graded-In. There is a \$30 U.S. upcharge plus the cost of the fabric price group selected.

Tip: The Designtex Environmental Impact collection does not require an **X** suffix unless the sewn upholstery detail is desired.

Tip: Always add suffixes in alphabetical order when specifying options to Leap seating.

Tip: Fire Code Seating (FCS) option is available with certain upholstery fabric choices only.
▶ Pages 289–290

▶ Detailed dimensions, page 26



For Canadian Pricing
Multiply U.S. Price by 1.38.
▶ See page 1 for details.

Specification Information

Full-Back
with Height-, Width-, and Pivot-
Adjustable Arms



• **Style
Number**

• **U.S.
Base
Price**

Full-Back
without Arms



• **Style
Number**

• **U.S.
Base
Price**

Without Adjustable Seat (No Seat Depth or Seat Edge Angle)

4621110 \$1028

4621100 \$ 803

With Adjustable Seat (Seat Depth and Seat Edge Angle)

4621210 \$1178

4621200 \$ 953

High-Back
with Height-, Width-, and Pivot-
Adjustable Arms



• **Style
Number**

• **U.S.
Base
Price**

High-Back
without Arms



• **Style
Number**

• **U.S.
Base
Price**

Without Adjustable Seat (No Seat Depth or Seat Edge Angle)

4621111 \$1078

4621101 \$ 853

With Adjustable Seat (Seat Depth and Seat Edge Angle)

4621211 \$1228

4621201 \$1003



For Canadian Pricing
Multiply U.S. Price by 1.38.
▶ See page 1 for details.

Leap 462 Series Full-Back Stools

Arch Backframe

Standard Upholstery on Back and Seat

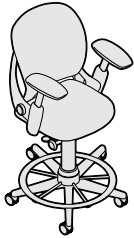

Standard Includes	Required to Specify
<p>▶ Need help? Product details, page 22</p> <ul style="list-style-type: none"> • Upper back force • 8" pneumatic seat-height adjustment • Variable back stop • Lower back firmness • Flexing front edge seat • Rectilinear independent height-, width-, and pivot-adjustable arms and soft arm caps, if selected: black plastic • Frame, seat shell, outer back, five-arm base, and foot ring: plastic • Adjustable foot ring 4" • On adjustable seat models: 2 1/4" seat depth adjustment and seat edge angle adjustment • Standard upholstery design: fabric price group 1 • 2"-diameter, hard-composition, dual-wheel casters: black 	<ol style="list-style-type: none"> 1 Style number 2 Plastic color for frame, seat shell, outer back, and foot ring 3 Fabric color number for upholstery on seat 4 Options, if selected (see below) <p>▶ See <i>Surface Materials</i>, page 282.</p>

Options	U.S. Price	Required to Specify																										
<table border="0"> <tr> <td style="vertical-align: top;">Surface Materials</td> <td> <ul style="list-style-type: none"> • Fabric price group 1 • Fabric price group 2 • Fabric price group 3 • Fabric price group 4 • Fabric price group 5 • Fabric price group 6 • Fabric price group 7 • Fabric price group 8 • Fabric price group 9 • Fabric price group 10 • Customer's Own Material (COM) or Designtex Graded-In • Steelcase leather upholstery • Steelcase vinyl • Customer's Own Leather (COL) or Customer's Own Vinyl (COV) • Fire Code Seating (FCS) • Soil-retardant treatment applied to upholstery fabric </td> <td> <p>No cost</p> <p>+\$ 20</p> <p>+\$ 40</p> <p>+\$ 55</p> <p>+\$ 70</p> <p>+\$ 85</p> <p>+\$100</p> <p>+\$125</p> <p>+\$155</p> <p>+\$175</p> <p>+\$ 30</p> <p>+\$590</p> <p>+\$299</p> <p>+\$299</p> <p>+\$ 50</p> <p>+\$ 17</p> </td> <td> <p>Specify fabric color number.</p> <p>Specify fabric color number.</p> <p>Specify fabric color number.</p> <p>Specify fabric color number.</p> <p>Specify fabric color number.</p> <p>Specify fabric color number.</p> <p>Specify fabric color number.</p> <p>Specify fabric color number.</p> <p>Specify fabric color number.</p> <p>Specify fabric color number.</p> <p>Add suffix X to the style number.</p> <p>▶ See <i>Surface Materials Reference Manual</i>.</p> <p>Add suffix S to the style number and specify leather color number.</p> <p>Add suffix S to the style number and specify vinyl color number.</p> <p>Add suffix S to the style number and specify leather or vinyl color number.</p> <p>▶ See <i>Surface Materials Reference Manual</i>.</p> <p>Add suffix F to the style number.</p> <p>Specify with soil-retardant treatment.</p> </td> </tr> <tr> <td style="vertical-align: top;">Stitched Edge Detail</td> <td> <ul style="list-style-type: none"> • Steelcase Classics Collection fabrics with stitched edge detail on back only </td> <td> <p>+\$ 30</p> </td> <td> <p>Add suffix X to the style number.</p> </td> </tr> <tr> <td style="vertical-align: top;">Fixed-Height Arms</td> <td> <ul style="list-style-type: none"> • Rectilinear soft arm caps • Rectilinear upholstered arm caps </td> <td> <p>-\$125</p> <p>-\$ 85</p> </td> <td> <p>Specify <i>with rectilinear fixed soft arms</i>.</p> <p>Specify <i>with rectilinear fixed upholstered arms</i>.</p> </td> </tr> <tr> <td style="vertical-align: top;">Independent Height-, Width-, and Pivot-Adjustable Arms</td> <td> <ul style="list-style-type: none"> • Rectilinear upholstered arm caps </td> <td> <p>+\$ 40</p> </td> <td> <p>Specify <i>with rectilinear height-, width-, and pivot-adjustable upholstered arms</i>.</p> </td> </tr> <tr> <td style="vertical-align: top;">Seat Depth</td> <td> <ul style="list-style-type: none"> • 2 1/4" seat depth adjustment: available on adjustable seat models only </td> <td> <p>-\$ 50</p> </td> <td> <p>Specify <i>with seat depth adjustment only</i>.</p> </td> </tr> <tr> <td style="vertical-align: top;">Lumbar Height</td> <td> <ul style="list-style-type: none"> • 5" travel for additional lumbar support </td> <td> <p>+\$ 50</p> </td> <td> <p>Specify <i>with adjustable lumbar height</i>.</p> </td> </tr> <tr> <td style="vertical-align: top;">Casters</td> <td> <ul style="list-style-type: none"> • Soft, dual-wheel casters for use on hard floors </td> <td> <p>+\$ 18</p> </td> <td> <p>Specify <i>with soft casters</i>.</p> </td> </tr> </table>	Surface Materials	<ul style="list-style-type: none"> • Fabric price group 1 • Fabric price group 2 • Fabric price group 3 • Fabric price group 4 • Fabric price group 5 • Fabric price group 6 • Fabric price group 7 • Fabric price group 8 • Fabric price group 9 • Fabric price group 10 • Customer's Own Material (COM) or Designtex Graded-In • Steelcase leather upholstery • Steelcase vinyl • Customer's Own Leather (COL) or Customer's Own Vinyl (COV) • Fire Code Seating (FCS) • Soil-retardant treatment applied to upholstery fabric 	<p>No cost</p> <p>+\$ 20</p> <p>+\$ 40</p> <p>+\$ 55</p> <p>+\$ 70</p> <p>+\$ 85</p> <p>+\$100</p> <p>+\$125</p> <p>+\$155</p> <p>+\$175</p> <p>+\$ 30</p> <p>+\$590</p> <p>+\$299</p> <p>+\$299</p> <p>+\$ 50</p> <p>+\$ 17</p>	<p>Specify fabric color number.</p> <p>Specify fabric color number.</p> <p>Specify fabric color number.</p> <p>Specify fabric color number.</p> <p>Specify fabric color number.</p> <p>Specify fabric color number.</p> <p>Specify fabric color number.</p> <p>Specify fabric color number.</p> <p>Specify fabric color number.</p> <p>Specify fabric color number.</p> <p>Add suffix X to the style number.</p> <p>▶ See <i>Surface Materials Reference Manual</i>.</p> <p>Add suffix S to the style number and specify leather color number.</p> <p>Add suffix S to the style number and specify vinyl color number.</p> <p>Add suffix S to the style number and specify leather or vinyl color number.</p> <p>▶ See <i>Surface Materials Reference Manual</i>.</p> <p>Add suffix F to the style number.</p> <p>Specify with soil-retardant treatment.</p>	Stitched Edge Detail	<ul style="list-style-type: none"> • Steelcase Classics Collection fabrics with stitched edge detail on back only 	<p>+\$ 30</p>	<p>Add suffix X to the style number.</p>	Fixed-Height Arms	<ul style="list-style-type: none"> • Rectilinear soft arm caps • Rectilinear upholstered arm caps 	<p>-\$125</p> <p>-\$ 85</p>	<p>Specify <i>with rectilinear fixed soft arms</i>.</p> <p>Specify <i>with rectilinear fixed upholstered arms</i>.</p>	Independent Height-, Width-, and Pivot-Adjustable Arms	<ul style="list-style-type: none"> • Rectilinear upholstered arm caps 	<p>+\$ 40</p>	<p>Specify <i>with rectilinear height-, width-, and pivot-adjustable upholstered arms</i>.</p>	Seat Depth	<ul style="list-style-type: none"> • 2 1/4" seat depth adjustment: available on adjustable seat models only 	<p>-\$ 50</p>	<p>Specify <i>with seat depth adjustment only</i>.</p>	Lumbar Height	<ul style="list-style-type: none"> • 5" travel for additional lumbar support 	<p>+\$ 50</p>	<p>Specify <i>with adjustable lumbar height</i>.</p>	Casters	<ul style="list-style-type: none"> • Soft, dual-wheel casters for use on hard floors 	<p>+\$ 18</p>	<p>Specify <i>with soft casters</i>.</p>
Surface Materials	<ul style="list-style-type: none"> • Fabric price group 1 • Fabric price group 2 • Fabric price group 3 • Fabric price group 4 • Fabric price group 5 • Fabric price group 6 • Fabric price group 7 • Fabric price group 8 • Fabric price group 9 • Fabric price group 10 • Customer's Own Material (COM) or Designtex Graded-In • Steelcase leather upholstery • Steelcase vinyl • Customer's Own Leather (COL) or Customer's Own Vinyl (COV) • Fire Code Seating (FCS) • Soil-retardant treatment applied to upholstery fabric 	<p>No cost</p> <p>+\$ 20</p> <p>+\$ 40</p> <p>+\$ 55</p> <p>+\$ 70</p> <p>+\$ 85</p> <p>+\$100</p> <p>+\$125</p> <p>+\$155</p> <p>+\$175</p> <p>+\$ 30</p> <p>+\$590</p> <p>+\$299</p> <p>+\$299</p> <p>+\$ 50</p> <p>+\$ 17</p>	<p>Specify fabric color number.</p> <p>Specify fabric color number.</p> <p>Specify fabric color number.</p> <p>Specify fabric color number.</p> <p>Specify fabric color number.</p> <p>Specify fabric color number.</p> <p>Specify fabric color number.</p> <p>Specify fabric color number.</p> <p>Specify fabric color number.</p> <p>Specify fabric color number.</p> <p>Add suffix X to the style number.</p> <p>▶ See <i>Surface Materials Reference Manual</i>.</p> <p>Add suffix S to the style number and specify leather color number.</p> <p>Add suffix S to the style number and specify vinyl color number.</p> <p>Add suffix S to the style number and specify leather or vinyl color number.</p> <p>▶ See <i>Surface Materials Reference Manual</i>.</p> <p>Add suffix F to the style number.</p> <p>Specify with soil-retardant treatment.</p>																									
Stitched Edge Detail	<ul style="list-style-type: none"> • Steelcase Classics Collection fabrics with stitched edge detail on back only 	<p>+\$ 30</p>	<p>Add suffix X to the style number.</p>																									
Fixed-Height Arms	<ul style="list-style-type: none"> • Rectilinear soft arm caps • Rectilinear upholstered arm caps 	<p>-\$125</p> <p>-\$ 85</p>	<p>Specify <i>with rectilinear fixed soft arms</i>.</p> <p>Specify <i>with rectilinear fixed upholstered arms</i>.</p>																									
Independent Height-, Width-, and Pivot-Adjustable Arms	<ul style="list-style-type: none"> • Rectilinear upholstered arm caps 	<p>+\$ 40</p>	<p>Specify <i>with rectilinear height-, width-, and pivot-adjustable upholstered arms</i>.</p>																									
Seat Depth	<ul style="list-style-type: none"> • 2 1/4" seat depth adjustment: available on adjustable seat models only 	<p>-\$ 50</p>	<p>Specify <i>with seat depth adjustment only</i>.</p>																									
Lumbar Height	<ul style="list-style-type: none"> • 5" travel for additional lumbar support 	<p>+\$ 50</p>	<p>Specify <i>with adjustable lumbar height</i>.</p>																									
Casters	<ul style="list-style-type: none"> • Soft, dual-wheel casters for use on hard floors 	<p>+\$ 18</p>	<p>Specify <i>with soft casters</i>.</p>																									

Tip: Use an **X** suffix when specifying COM or Designtex Graded-In. There is a \$30 U.S. upcharge plus the cost of the fabric price group selected.

Tip: The Designtex Environmental Impact collection does not require an **X** suffix unless the sewn upholstery detail is desired.

Tip: Always add suffixes in alphabetical order when specifying options to Leap seating.

Tip: Fire Code Seating (FCS) option is available with certain upholstery fabric choices only.

▶ Pages 289–290

▶ Detailed dimensions, page 26



For Canadian Pricing
Multiply U.S. Price by 1.38.
▶ See page 1 for details.

Specification Information

Full-Back
with Height-, Width-, and Pivot-
Adjustable Arms



Full-Back
without Arms



• **Style
Number**

• **U.S.
Base
Price**

• **Style
Number**

• **U.S.
Base
Price**

Without Adjustable Seat (No Seat Depth or Seat Edge Angle)

4627110

\$1205

4627100

\$ 980

With Adjustable Seat (Seat Depth and Seat Edge Angle)

4627210

\$1355

4627200

\$1130



For Canadian Pricing
Multiply U.S. Price by 1.38.
▶ See page 1 for details.



Understanding and Specifying Leap 464 Series WorkLounge Work Chairs

Understanding Leap 464 Series WorkLounge

Details	62
Dimensions	64

Specifying Criterion 464 Series WorkLounge

WorkLounge and Ottoman	66
Coach Edition Leather WorkLounge and Ottoman	68

Work Chairs

Highly adjustable task seating offers maximum personalization for people who sit most of the day performing repetitive tasks. By making a series of simple adjustments, you can customize the chair to your body, preferences, and tasks. These chairs provide continuous, stable, task-oriented comfort, and can be quickly adjusted to support you in upright, forward, and reclining work postures.

- Leap 462 Series
- Leap 464 Series WorkLounge
- Criterion 453 Series
- Think 465 Series
- Drive 461 Series
- Jersey Series
- Sensor 458 Series

Adjustability Features

► See page 11 for a comparison to other chairs. **Leap 464 Series**

Mechanisms

Natural glide ●

Seat Adjustments

Pneumatic height ●

Back Adjustments

Lower back firmness ●

Upper back tension ●

Variable back stop ●

Headrest with flip-up pillow ●

Leap 464 Series WorkLounge

WorkLounge—a chair designed especially for people who like to work in a deep, reclined posture.

Headrest and flip-up pillow provide neck and head support.

Live back moves with the shape of the user's spine as sitting positions change.

Fixed arms have extra padding to provide forearm support and comfort.

Outer back is fully upholstered.

Ribbon backframe is standard.

Lower back firmness changes the amount of firmness user feels in lower back. Requires only two complete turns.

Upper back force requires only five complete turns and accommodates a broader range of users by allowing user to change the rate of increase in force as the user reclines.

Variable back stop with five positions is standard.

Seat height adjusts within a 3" range with a pneumatic adjustment mechanism.

Extra thick seat cushion provides extra comfort.

Five-arm base is standard with glides. 3" hard or soft casters are available as options.

Polished aluminum is standard on ribbon backframe, arm supports, base, and casters.

Ottoman quickly and easily converts from a footrest to an auxiliary work table.

Work table, with top up, is 25"H from the floor.

Footrest is cushioned and upholstered. Footrest surface is 15"H from the floor.

Polished aluminum is standard on post and four-arm base.

Four-arm base is standard with two glides and two hard, dual-wheel casters.

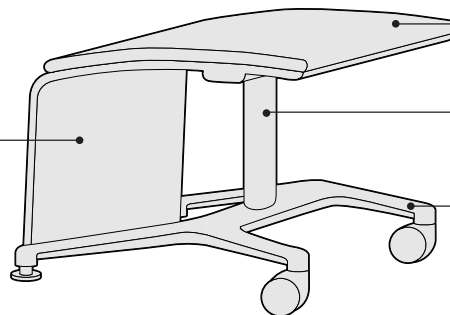
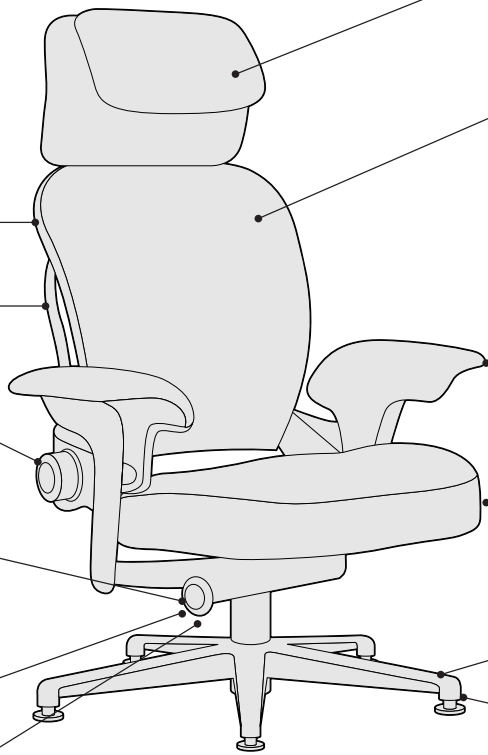

Product Details

Adjustability instructions are included with every chair and ottoman.

Controls under the seat include tactile braille designators.

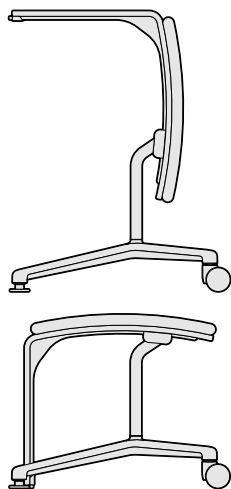

Ottoman easily converts between two positions. With the top up, it is a work table; with the top down it is a footrest. Locking pivot mechanism holds each position in place.

Adjustment Features

Seat Adjustments

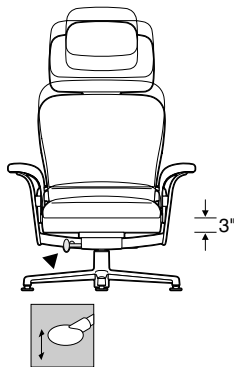

Seat height adjusts pneumatically. To lower, hold handle up while seated. To raise, hold handle up and keep your weight off the chair. This feature is standard. Range of adjustability is 3" from 15"H–18"H with standard glides and 17"H–20"H with optional casters.

Back Adjustments

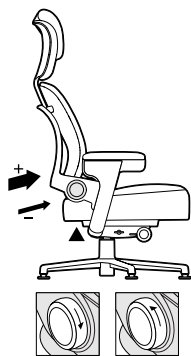

Lower back firmness adjusts by turning knob two complete turns. Forward increases firmness. Backward decreases firmness. This feature is standard.

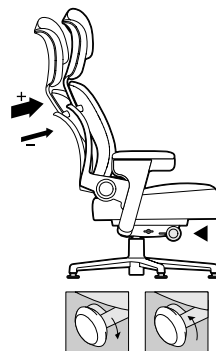

Upper back force adjusts by turning knob five complete turns. Turn knob forward to increase rate of tension; backward to decrease. This feature is standard.

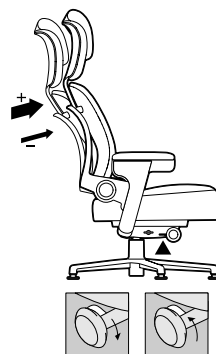

Variable back stop. Rotate handle up or down to set recline angle. Lean back to desired back angle. Five stops are available. This feature is standard.
Tip: To stop in upright position, remove weight from back and rotate lever up.

Other Features

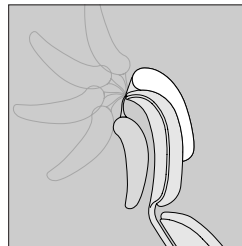

Flip-up pillow can be positioned for use on headrest or placed over the backside of headrest when not in use. This feature is standard.

Glides are standard.

Casters are optional. 3" polished aluminum hard- or soft-wheel casters are available.

Surface Materials

▶ See surface materials on page 282 for specific availability or refer to the *Surface Materials Reference Manual* for further information.

Upholstery

- Designtex Wool Suede Too
- Elmo Rustical Leather
- Coach Leather

Hard components

(Seat shell, glides, and casters)

- 6205 Black

Polished aluminum

is standard on chair and ottoman. Polished aluminum is applied to ribbon backframe, arm supports, base, and casters of chair. Ottoman has polished aluminum on post and base.

Programs & Services

▶ See the *Surface Materials Reference Manual* for further detail about programs and services offered for seating.

The Customer's Own Material (COM & COL) Program

offers the opportunity for customers to select fabrics and leather that are not offered through the standard Steelcase surface materials program for use on Steelcase products. Avoid pattern fabrics and heavily grained leathers. Through the COM & COL program, Steelcase will test your materials for application on Steelcase products. Once approved, you can place your order. Steelcase will facilitate the entire ordering process and give you a production schedule. Steelcase will order the COM & COL fabric and leather directly from the textile manufacturer. For up-to-date information regarding fabric test results for all COM & COL fabrics and details regarding yardage requirements for most Seating lines, visit the COM Web site. To locate the COM Web site:

- Visit www.steelcase.com
- Click on "Knowledge & Design"
- Select "Customer's Own Material"

Dimensions

▶ Page 64

Resources

Printed Materials

- ▶ Leap WorkLounge and Ottoman Brochure (S11526)
- ▶ Leap WorkLounge Hangtag (LP-00052)
- ▶ Leap WorkLounge Ottoman Hangtag (LP-00054)
- ▶ Leap Brochure (S11478)
- ▶ Why Leap (S11014)
- ▶ Leap Overview Positioning Piece (S11016)
- ▶ Leap White Paper Packets (S11019)
- ▶ Leap Quick Reference Pocket Card (S11042)
- ▶ Leap User Guide (S11236)
- ▶ Seating Overview (03-0003368)

Computer Tools

- ▶ Electronic User Disk (S2305)—Windows
- ▶ Leap CD-ROM (S11015)
- ▶ www.steelcase.com

Dimensions

Leap 464 Series

	Overall Depth	Width	Height	Seat Depth	Functional Seat Depth	Seat Width	Seat Height from Floor	Back Width	Back Height from Seat
Leap 464 Series									
WorkLounge									
	26 1/2"	31 1/2"	43 1/2" to 46 1/2" with glides 45 1/2" to 48 1/2" with casters	21 3/4"	18 1/2"	20"	15" to 18" with glides 17" to 20" with casters	20 1/2"	30"
Ottoman									
	19"	18 1/2"	15"	N.A.	N.A.	16 3/4"	15"	N.A.	N.A..

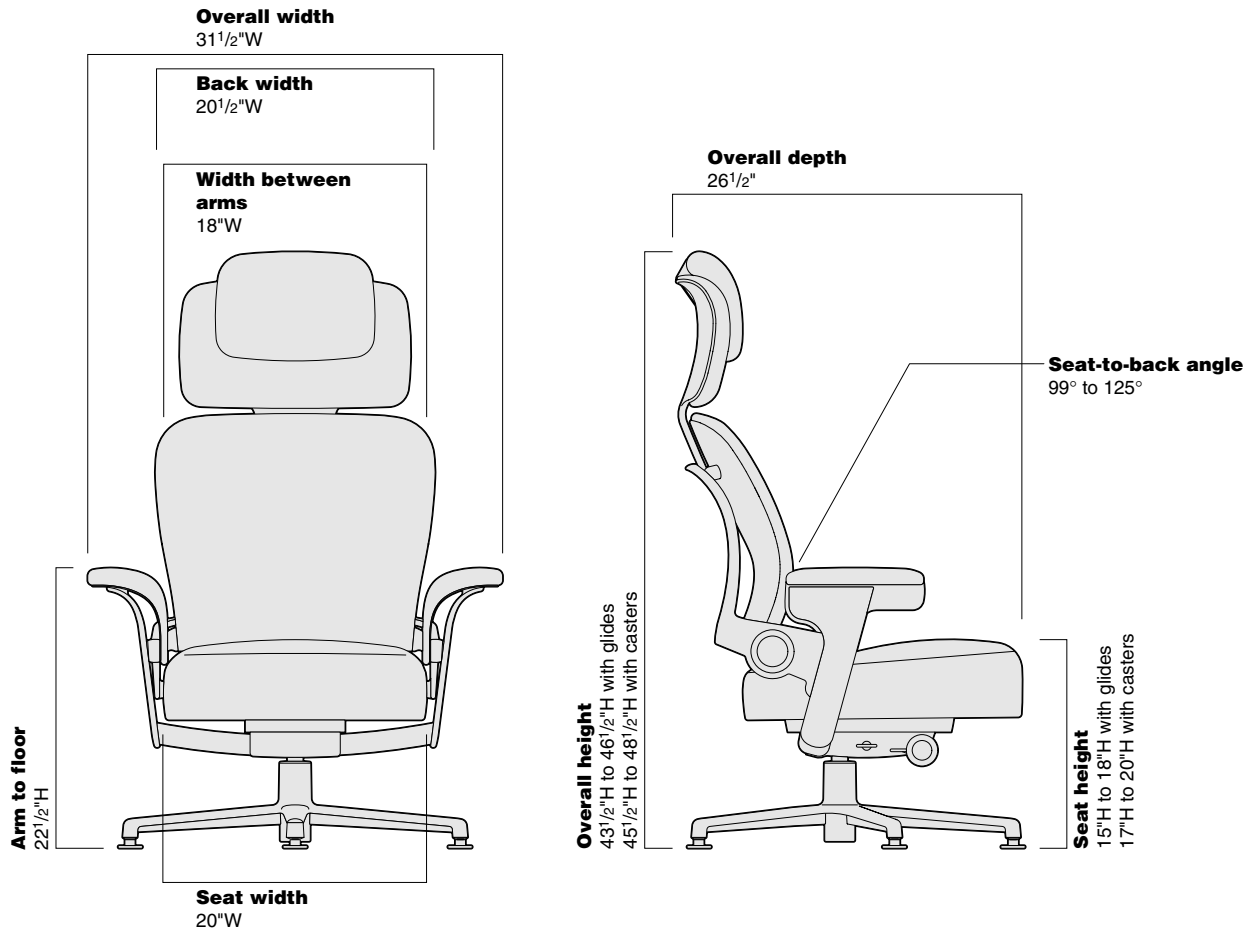

Lumbar Flex Zone	Width Between Arms	Arm to Floor	Arm Height from Seat	Angle Between Seat and Back	Table Height from Floor
------------------	--------------------	--------------	----------------------	-----------------------------	-------------------------

WorkLounge

5¼" to 10¼"	18"	22½"	8¼"	99°–125°	N.A.
-------------	-----	------	-----	----------	------

Ottoman

N.A.	N.A.	N.A.	N.A.	N.A.	25"
------	------	------	------	------	-----

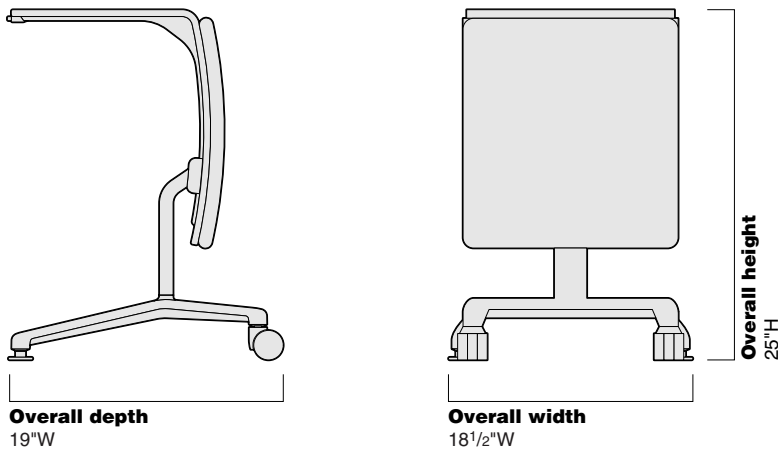
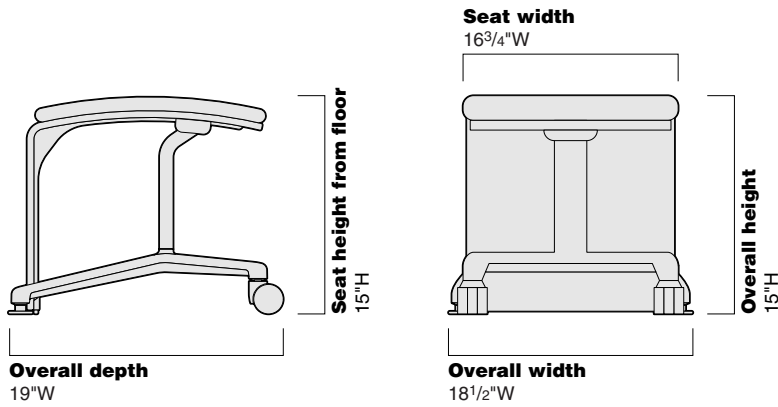

Leap 464 Series WorkLounge and Ottoman

Leap 464 Series WorkLounge

Ribbon Backframe



	Standard Includes	Required to Specify
▶ Need help? Product details, page 62	<ul style="list-style-type: none"> Fully upholstered back, seat, arms, headrest, and flip-up pillow: Designtex Wool Suede Too Upper back force Variable back stop Lower back firmness Fixed, non-adjustable arms 3" pneumatic seat-height adjustment Seat and back components: black plastic only Ribbon backframe, arm supports and five-arm base: polished aluminum only Glides: black with stainless steel inserts. 	<ol style="list-style-type: none"> Style number Fabric color number for upholstery on back, seat, arms, headrest, and flip-up pillow Options, if selected (see below) <ul style="list-style-type: none"> ▶ See <i>Surface Materials</i>, page 282.

	Options	U.S. Price	Required to Specify
Surface Materials	• Designtex Wool Suede Too	No cost	Specify with 59DG and fabric color number. ▶ See <i>Surface Materials</i> , page 282.
	• Elmo Rustical leather	+\$550	Specify with 59DK and leather color number. ▶ See <i>Surface Materials</i> , page 282.
	• Customer's Own Material (COM)	+\$ 30	▶ See <i>Surface Materials Reference Manual</i> to specify.
	• Customer's Own Leather (COL)	+\$ 30	▶ See <i>Surface Materials Reference Manual</i> to specify.
Casters	• 3" hard-composition, dual-wheel casters for use on carpet: polished aluminum and black	+\$ 55	Specify with hard casters.
	• 3" soft, dual-wheel casters for use on hard floors: polished aluminum and black	+\$ 55	Specify with soft casters.

Specification Information

Style Number	U.S. Base Price
464LOUNGE	\$2350

▶ Detailed dimensions, page 64



For Canadian Pricing
Multiply U.S. Price by 1.38.
▶ See page 1 for details.

Leap 464 Series Ottoman



	Standard Includes	Required to Specify
▶ Need help? Product details, page 62	<ul style="list-style-type: none"> Upholstery on footrest: Designtex Wool Suede Too Work table and footrest shell: black plastic only Post and four-arm base: polished aluminum Two glides: black with stainless steel inserts Two 2"-diameter, hard-composition, dual-wheel casters: black 	<ol style="list-style-type: none"> Style number Fabric color number for upholstery on footrest Options, if selected (see below) ▶ See <i>Surface Materials</i> , page 282.

	Options	U.S. Price	Required to Specify
Surface Materials	• Designtex Wool Suede Too	No cost	Specify with 59DG and fabric color number.
	• Elmo Rustical leather	+\$125	▶ See <i>Surface Materials</i> , page 282. Specify with 59DK and leather color number.
	• Customer's Own Material (COM)	+\$ 30	▶ See <i>Surface Materials</i> , page 282.
	• Customer's Own Leather (COL)	+\$ 30	▶ See <i>Surface Materials Reference Manual</i> to specify. ▶ See <i>Surface Materials Reference Manual</i> to specify.

Specification Information

Style Number	U.S. Base Price
464OTTOMAN	\$700

▶ Detailed dimensions,
page 64



For Canadian Pricing
Multiply U.S. Price by 1.38.
▶ See page 1 for details.

Leap 464 Series Coach Edition Leather WorkLounge and Ottoman

Leap 464 Series Coach Edition Leather WorkLounge

Ribbon Backframe



Standard Includes		Required to Specify
<ul style="list-style-type: none"> ▶ Need help? Product details, page 62 	<ul style="list-style-type: none"> Fully upholstered back, seat, lumbar pillow, arms, headrest, and flip-up pillow: Coach leather Upper back force Variable back stop Lower back firmness Fixed, non-adjustable arms 3" pneumatic seat-height adjustment Seat and back components: black plastic only Ribbon backframe, arm supports and five-arm base: polished aluminum only Glides: black with stainless steel inserts. Coach Edition lumbar pillow 	<ul style="list-style-type: none"> 1 Style number 2 Coach leather color number for upholstery on back, seat, lumbar pillow, arms, headrest, and flip-up pillow (with matching or contrasting thread stitching) 3 Options, if selected (see below) <ul style="list-style-type: none"> ▶ See <i>Surface Materials</i>, page 282.

Options	U.S. Price	Required to Specify
Casters		
<ul style="list-style-type: none"> 3" hard-composition, dual-wheel casters for use on carpet: polished aluminum and black 	+\$55	Specify <i>with hard casters</i> .
<ul style="list-style-type: none"> 3" soft, dual-wheel casters for use on hard floors: polished aluminum and black 	+\$55	Specify <i>with soft casters</i> .

Specification Information	
Style Number	U.S. Base Price
464COACHL	\$3600
.	.
.	.

▶ Detailed dimensions, page 64

 **For Canadian Pricing**
 Multiply U.S. Price by 1.38.
 ▶ See page 1 for details.

Leap 464 Series Coach Edition Leather Ottoman



Standard Includes		Required to Specify
<ul style="list-style-type: none"> ▶ Need help? Product details, page 62 	<ul style="list-style-type: none"> • Upholstery on footrest: Coach leather • Work table and footrest shell: black plastic only • Post and four-arm base: polished aluminum • Two glides: black with stainless steel inserts • Two 2"-diameter, hard-composition, dual-wheel casters: black 	<ul style="list-style-type: none"> 1 Style number 2 Coach leather color number for upholstery on footrest (with matching or contrasting thread stitching) ▶ See <i>Surface Materials</i>, page 282.

Specification Information

Style Number	U.S. Price
464COACHO	\$900

▶ Detailed dimensions, page 64



For Canadian Pricing
Multiply U.S. Price by 1.38.
▶ See page 1 for details.



Understanding and Specifying Criterion 453 Series Work Chairs

Understanding Criterion 453 Series

Details	72
Dimensions	76

Specifying Criterion 453 Series

High-Back Work Chairs	78
Mid-Back Work Chairs	80
High-Back Stools	82
Mid-Back Stools	84
Plus High-Back Work Chairs	86

Work Chairs

Highly adjustable task seating offers maximum personalization for people who sit most of the day performing repetitive tasks. By making a series of simple adjustments, you can customize the chair to your body, preferences, and tasks. These chairs provide continuous, stable, task-oriented comfort, and can be quickly adjusted to support you in upright, forward, and reclining work postures.

- Leap 462 Series
- Leap 464 Series WorkLounge
- Criterion 453 Series
- Think 465 Series
- Drive 461 Series
- Jersey Series
- Sensor 458 Series

Adjustability Features

▶ See page 11 for a comparison to other chairs.

	Criterion	Criterion Plus
Mechanisms		
Advanced swivel tilt	●	●
Seat Adjustments		
Pneumatic height	●	●
Seat angle	●	●
Seat depth	●	●
Back Adjustments		
Lumbar height	●	●
Back tension	●	●
Variable back stop	●	
Upright back lock		●
Back height	●	●
Arm Adjustments		
Arm height	●	●
Arm width	●	●
Arm pivot	●	
Other Features		
Foot ring height on stool	●	

Criterion 453 Series

Criterion is a high-performance chair, ideal for users who sit for long periods of time. As one of the world's best-selling chairs with a broad range of adjustments, Criterion meets the long-term comfort needs of today's diverse workforce.

Outer back and outer seat is plastic. Fully upholstered outer back is an option.

Arm height adjusts independently within a 4" range to help relieve upper back and shoulder fatigue.

Seat depth adjusts within a 3" range and is available as an option.

Seat height adjusts within a 5" range with a pneumatic adjustment mechanism.

Five-arm base is standard.

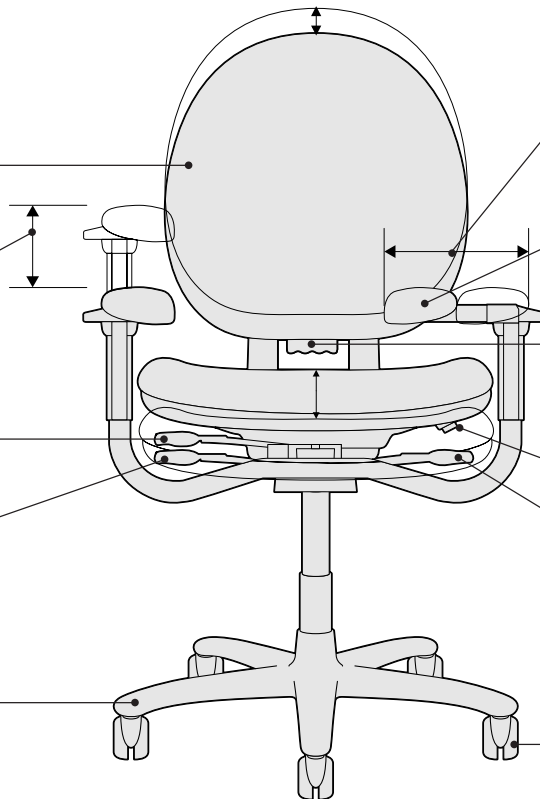

Arm width adjusts within a 4" range for each arm to provide forearm support in neutral position for 5th to 95th percentile office workers.

Arm caps can pivot independently 14° in and 21° out to accommodate individual user preferences.

Back height adjusts up and down within a 2" range to help ensure healthful back posture.

Variable back stop is standard.

Seat angle adjusts forward, upright, and reclined to suit user. Seat angle is standard.

Casters have hard, dual-wheels that roll smoothly on carpets. Soft, dual-wheel casters are available for use on hard floors or chair mats.

Product Details



Three basic sizes are available—high-back, mid-back, and Plus. All are offered with and without arms. High-back and mid-back are also available as stools.

Criterion features a seat angle adjustment which allows the seat angle to function in a fixed or articulating mode. Variable back stop will lock the back in an upright position or allow the user to set a specific back stop position which the chair will recline to.

Criterion Plus has an upright back lock and offers a wider seat with more space between the arms to accommodate workers who need a larger chair. The Criterion Plus chair is tested to hold up to 500 lbs. under normal use.

Adjustment Features

Seat Adjustments

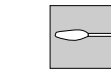
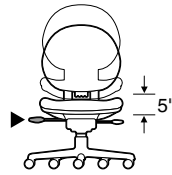

Seat height adjusts pneumatically. To lower, hold handle up while seated. To raise, hold handle up and keep your weight off the chair. Range of adjustability is 5" from 16"H to 21"H.



Seat angle adjusts by pulling handle up and shifting your weight to alter seat angle. Release handle to lock. This feature is standard.

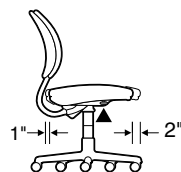

Seat depth adjusts by pulling handle up. Slide seat forward or back to accommodate various leg lengths. Release handle to lock. This feature is optional.

Back Adjustments

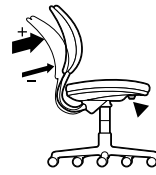

Back tension adjusts by turning knob. Turn knob clockwise to increase tension, counterclockwise to decrease. This feature is standard.

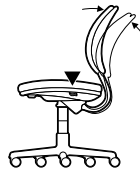

Variable back stop. Hold switch forward to recline. Lean back to desired back angle. Release switch to set tilt range.
Tip: To lock in upright position, remove weight from back and release switch.

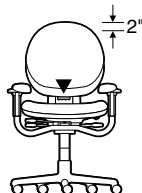

Back height adjusts within a 2" range by pulling handle forward while moving chair back up or down. Release handle to lock chair back in position. This feature is standard.

Arm Adjustments

Arms are available fixed, height-adjustable, height- and width-adjustable, and height-, width-, and pivot-adjustable.

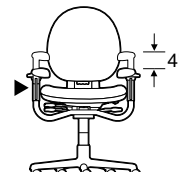

Arm height adjusts independently within a range of 4" on all adjustable arm models. Squeeze triggers in while moving arms up or down. Releasing triggers locks arms in position.

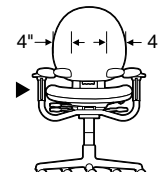

Arm width adjusts independently on chairs with the height- and width-adjustable option. Grasp arm and move in or out. Arm will stay where positioned.

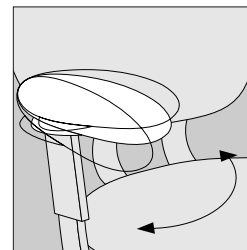

Arms pivot independently on models with height-, width-, and pivot-adjustable arms. Grasp arm and push front to left or right. Pivot adjustment width range is 10¾" to 18¼".

Other Features

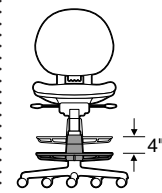

Foot ring height on stools adjusts by first lifting ring and rotating it counterclockwise to unlock it. Then raise or lower ring up to 4" to desired position before rotating it clockwise to lock it.

Alternative casters and glides are available for specific applications, including soft-wheel casters for hard floors.

Glides are 2"H and interchangeable with casters.

Surface Materials

▶ See surface materials on page 282 for specific availability or refer to the *Surface Materials Reference Manual* for further information.

Upholstery

- Fabric
- Fabric with soil-retardant treatment (option)
- Vinyl

Hard components

(base, arms, plastic arm caps, outer back, outer seat, and foot ring)

- Monochromatic color from list of seating plastic color numbers will apply to all hard components.

Outer back and outer seat

- Plastic color to match color of other “hard components”
- Fully upholstered outer back with plastic color outer seat

Arms

- Soft vinyl arm caps to match the plastic color of the other “hard components”
- Upholstered arm caps

Foot ring on stools

- Plastic color to match other “hard components”
- 9201 Polished Chrome

Glides

- Stainless steel only

All Steelcase seating with standard upholstery fabrics

complies with requirements of the BIFMA First Generation Voluntary Upholstered Furniture Flammability Standard, as well as the State of California Technical Bulletin 117. All standard seating is labeled to be in compliance with California TB117.

Programs & Services

▶ See the *Surface Materials Reference Manual* for further detail about programs and services offered for seating.

The Customer’s Own Material (COM) Program

offers the opportunity for customers to select fabrics that are not offered through the standard Steelcase surface materials program for use on Steelcase products. Through the COM program, Steelcase will test your materials for application on Steelcase products. Once approved, you can place your order. Steelcase will facilitate the entire ordering process and give you a production schedule. Steelcase will order the COM fabric directly from the textile manufacturer. For up-to-date information regarding fabric test results for all COM fabrics and details regarding yardage requirements for most Seating lines, visit the COM Web site. To locate the COM Web site:

- Visit www.steelcase.com
- Click on “Knowledge & Design”
- Select “Customer’s Own Material”

Soil retardants are treatments that provide long-term soil and stain resistance to a fabric without affecting the shade or the integrity of the fabric. The following Steelcase Textiles are available pre-treated with soil retardant. (You do not need to select the soil-retardant option for these fabrics and incur the \$17 upcharge.)

- Canzoné
- Cavalcade
- Jacks
- Link
- Regis
- Rook
- Roulette
- Skittles
- Spyder
- Sweepstakes

Soil-retardant treatment is available on all other seating fabrics at an additional \$17 U.S. per seating unit. To order this option, please select “Soil-Retardant Treatment” under “Optional Accessories.”

For soil-retardant treatment on COMs, please select “Soil-Retardant Treatment” under “Optional Accessories.” Minimums or additional yardage may be required. Please contact the vendor directly for specific information.

Extended lead times may be necessary for this service.

Contact your Steelcase Sales Service representative at 1.888.STEELCASE (1.888.783.3522).

Fire Codes

▶ See pages 289–290 for upholstery fabrics available for use with FCS modification.

Steelcase offers Fire Code Seating modification (FCS) on nearly all seating models. The most rigorous fire codes in the nation have been developed in California, and the Steelcase FCS modification is designed to meet those codes. Fire Code Seating (FCS) indicates that a product is constructed to meet the strict fire code requirements of high public occupancy areas such as theaters, meeting rooms, and lobbies. The FCS standards will meet both the State of California Home Furnishing Technical Bulletin 133 (Cal TB 133) and Boston Fire Code (BFC). Boston adopted the California Home Furnishing Technical Bulletin TB 133 test standard in 1992.

Local codes may have special requirements for upholstery.

Dimensions

▶ Page 76

Resources

Printed Materials

- ▶ Criterion Brochure (S11524)
- ▶ Criterion Plus Sheet (S2396)
- ▶ Criterion Testimonial Sheet (S10846)
- ▶ Seating Overview (03-0003368)

Video and Audio Materials

- ▶ Criterion User Video (S70427)

Computer Tools

- ▶ Interactive User Guide available on www.steelcase.com
- ▶ Electronic User Disk (S2305)—Windows

Dimensions

Criterion 453 Series

	Overall Depth	Width	Height	Seat Depth	Functional Seat Depth	Seat Width	Seat Height from Floor	Back Width	Back Height from Seat
Criterion 453 Series									
High-Back Work Chairs	22½"-25½"	27½"	37½"-44½"	19½"	16¼"*	19½"	16"-21"	18"	22"-24"
Mid-Back Work Chairs	22½"-25½"	27½"	34"-41"	19½"	16¼"*	19½"	16"-21"	18"	19½"-21½"
High-Back Stools	22½"-25½"	27½"	46"-53"	19½"	16¼"*	19½"	25"-30"	18"	22"-24"
Mid-Back Stools	22½"-25½"	27½"	43"-50"	19½"	16¼"*	19½"	25"-30"	18"	19½"-21½"
Plus High-Back Work Chairs	22½"-25½"	31½"	38"-45"	19¾"	18¼"	23"	17"-22"	22"	23"-25"

*Models with adjustable seat depth 15¼"-18¼".

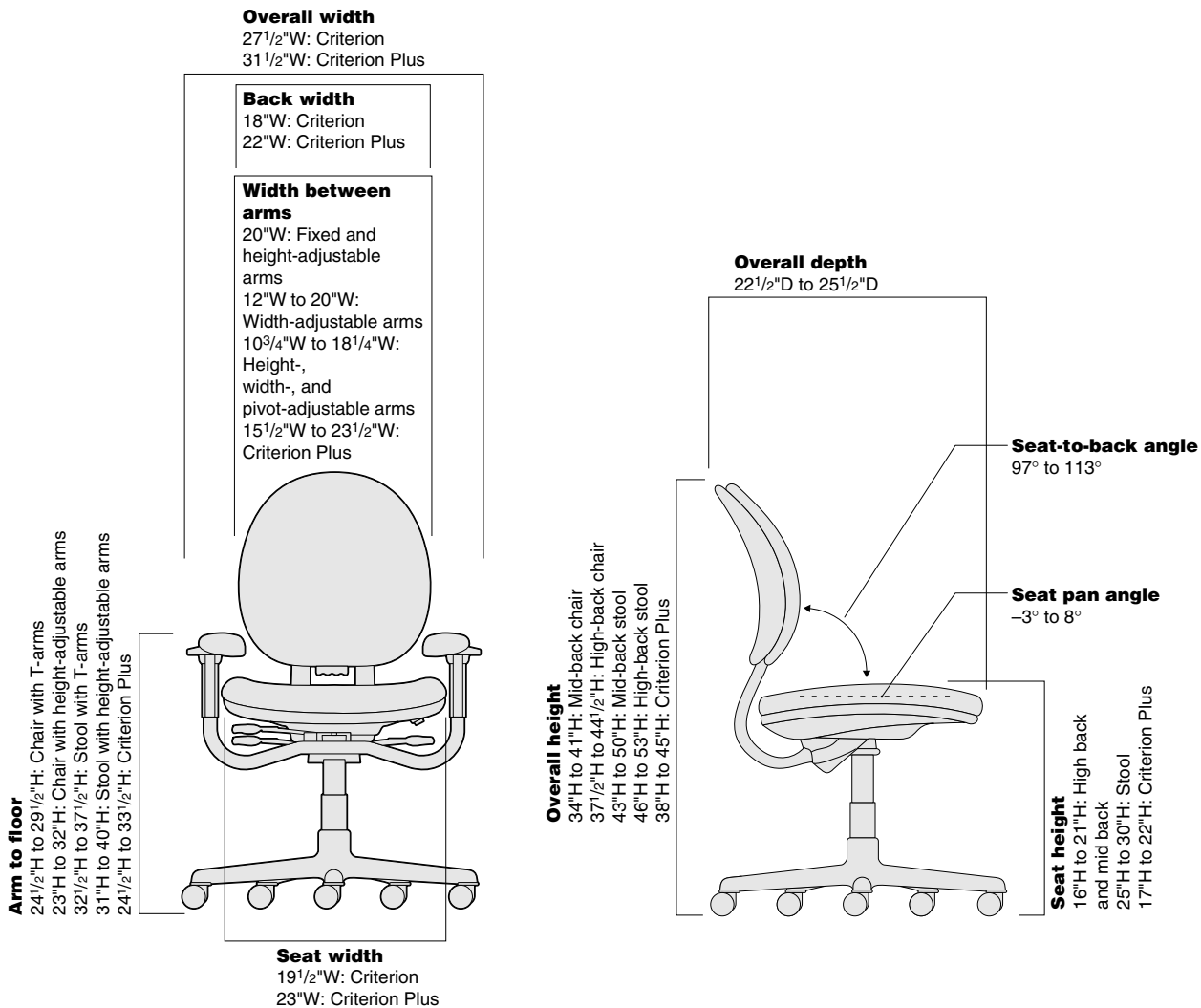

• Back Lumbar Height	• Width Between Fixed-Height and Adjustable-Height Arms	• Width Between Height- and Width-Adjustable Arms	• Width Between Height-, Width-, and Pivot-Adjustable Arms	• Arm to Floor	• Arm Height from Seat	• Arm Cap Pivot Range	• Seat Pan Angle	• Angle Between Seat and Back	• Foot Ring Width	• Foot Ring Height
High-Back Work Chairs										
8"	20"	12"-20"	10 ³ / ₄ "-18 ¹ / ₄ "	23"-32"	7"-11"	35°	-3°-+8°	97°-113°	N.A.	N.A.
Mid-Back Work Chairs										
8"	20"	12"-20"	10 ³ / ₄ "-18 ¹ / ₄ "	23"-32"	7"-11"	35°	-3°-+8°	97°-113°	N.A.	N.A.
High-Back Stools										
8"	20"	12"-20"	10 ³ / ₄ "-18 ¹ / ₄ "	31"-40"	7"-11"	35°	-3°-+8°	97°-113°	19 ¹ / ₂ "	9"-13"
Mid-Back Stools										
8"	20"	12"-20"	10 ³ / ₄ "-18 ¹ / ₄ "	31"-40"	7"-11"	35°	-3°-+8°	97°-113°	19 ¹ / ₂ "	9"-13"
Plus High-Back Work Chairs										
9"	23 ¹ / ₂ "	15 ¹ / ₂ "-23 ¹ / ₂ "	N.A.	24 ¹ / ₂ "-33 ¹ / ₂ "	7 ¹ / ₂ "-11 ¹ / ₂ "	N.A.	-3°-+8°	97°-113°	N.A.	N.A.

Criterion 453 Series High-Back Work Chairs



Standard Includes		Required to Specify
<ul style="list-style-type: none"> ▶ Need help? Product details, page 72 	<ul style="list-style-type: none"> • Back height adjustment • Seat angle adjustment • Variable back stop • Back tension adjustment • Arms, if selected: plastic color to match base • Outer back and outer seat: plastic color • Upholstery: fabric price group 1 • Five-arm base: plastic color • 2½"-diameter, hard composition, dual-wheel casters: plastic color to match base 	<ol style="list-style-type: none"> 1 Style number 2 Plastic color number for base, outer back, outer seat, arms, and casters 3 Fabric color number for upholstery 4 Options, if selected (see below) <ul style="list-style-type: none"> ▶ See <i>Surface Materials</i>, page 282.

Tip: Always add suffixes in alphabetical order when specifying options to Criterion seating.

Tip: Fire Code Seating (FCS) option is available only on models with both adjustable seat depth (**D** suffix) and 6205 Black plastic components.
▶ See pages 289–290 for upholstery fabric choices.

Options	U.S. Price	Required to Specify
Surface Materials	Upholstery <ul style="list-style-type: none"> • Fabric price group 1 No cost • Fabric price group 2 +\$ 20 • Fabric price group 3 +\$ 40 • Fabric price group 4 +\$ 55 • Fabric price group 5 +\$ 70 • Fabric price group 6 +\$ 85 • Fabric price group 7 +\$100 • Fabric price group 8 +\$125 • Fabric price group 9 +\$155 • Fabric price group 10 +\$175 • Seating vinyl +\$ 35 <p><i>Not available on upholstered outer back or upholstered arm cap models.</i></p> <ul style="list-style-type: none"> • Customer's Own Material (COM) +\$ 30 • Fire Code Seating (FCS) +\$ 50 • Soil-retardant treatment applied to upholstery fabric +\$ 17 	Specify fabric color number. Specify fabric color number. Specify fabric color number. Specify fabric color number. Specify fabric color number. Specify fabric color number. Specify fabric color number. Specify fabric color number. Specify fabric color number. Add suffix V to the style number and specify seating vinyl color number.
	Fully upholstered <ul style="list-style-type: none"> • Outer back +\$ 50 	Add suffix B to the style number.
Casters	<ul style="list-style-type: none"> • Soft, dual-wheel casters for use on hard floors +\$ 18 	Specify <i>with soft casters</i> .
Glides	<ul style="list-style-type: none"> • Plastic glide with stainless steel cap No cost 	Specify <i>with GLD453</i> .

▶ See *Surface Materials Reference Manual* to specify.
Add suffix **F** to the style number.
Specify *with soil-retardant treatment*.

Specification Information

Height-, Width-, and Pivot-Adjustable Arms



• Style Number	• U.S. Base Price
.....

Soft Arm Caps

Pneumatic

4535331P \$909

Pneumatic with Adjustable Seat Depth

4535331DP \$984

▶ Specification Information continued on next page

▶ Detailed dimensions, page 76



For Canadian Pricing
Multiply U.S. Price by 1.38.
▶ See page 1 for details.

Criterion 453 Series Mid-Back Work Chairs



Standard Includes		Required to Specify
<ul style="list-style-type: none"> ▶ Need help? Product details, page 72 	<ul style="list-style-type: none"> • Back height adjustment • Seat angle adjustment • Variable back stop • Back tension adjustment • Arms, if selected: plastic color to match base • Outer back and outer seat: plastic color • Upholstery: fabric price group 1 • Five-arm base: plastic color • 2½"-diameter, hard composition, dual-wheel casters: plastic color to match base 	<ol style="list-style-type: none"> 1 Style number 2 Plastic color number for base, outer back, outer seat, arms, and casters 3 Fabric color number for upholstery 4 Options, if selected (see below) <p>▶ See <i>Surface Materials</i>, page 282.</p>

Tip: Always add suffixes in alphabetical order when specifying options to Criterion seating.

Tip: Fire Code Seating (FCS) option is available only on models with both adjustable seat depth (**D** suffix) and 6205 Black plastic components.
▶ See pages 289–290 for upholstery fabric choices.

Options	U.S. Price	Required to Specify
Surface Materials	Upholstery <ul style="list-style-type: none"> • Fabric price group 1 No cost • Fabric price group 2 +\$ 20 • Fabric price group 3 +\$ 40 • Fabric price group 4 +\$ 55 • Fabric price group 5 +\$ 70 • Fabric price group 6 +\$ 85 • Fabric price group 7 +\$100 • Fabric price group 8 +\$125 • Fabric price group 9 +\$155 • Fabric price group 10 +\$175 • Seating vinyl +\$ 35 <p><i>Not available on upholstered outer back or upholstered arm cap models.</i></p> <ul style="list-style-type: none"> • Customer's Own Material (COM) +\$ 30 • Fire Code Seating (FCS) +\$ 50 • Soil-retardant treatment applied to upholstery fabric +\$ 17 	<ul style="list-style-type: none"> Specify fabric color number. Specify fabric color number. Specify fabric color number. Specify fabric color number. Specify fabric color number. Specify fabric color number. Specify fabric color number. Specify fabric color number. Specify fabric color number. Specify fabric color number. Add suffix V to the style number and specify seating vinyl color number. <p>▶ See <i>Surface Materials Reference Manual</i> to specify. Add suffix F to the style number. Specify <i>with soil-retardant treatment</i>.</p>
	Fully upholstered <ul style="list-style-type: none"> • Outer back +\$ 50 	<ul style="list-style-type: none"> Add suffix B to the style number.
Casters	<ul style="list-style-type: none"> • Soft, dual-wheel casters for use on hard floors +\$ 18 	<ul style="list-style-type: none"> Specify <i>with soft casters</i>.
Glides	<ul style="list-style-type: none"> • Plastic glide with stainless steel cap No cost 	<ul style="list-style-type: none"> Specify <i>with GLD453</i>.

Specification Information

Height-, Width-, and Pivot-Adjustable Arms



• Style Number	• U.S. Base Price
.....

Soft Arm Caps

Pneumatic

4535330P \$865

Pneumatic with Adjustable Seat Depth

4535330DP \$940

▶ Specification Information continued on next page

▶ Detailed dimensions, page 76



For Canadian Pricing
Multiply U.S. Price by 1.38.
▶ See page 1 for details.

► Specification Information, continued

Specification Information

Height- and Width Adjustable Arms



• Style
Number
• U.S.
Base
Price

Height-Adjustable Arms



• Style
Number
• U.S.
Base
Price

Fixed-Height Arms



• Style
Number
• U.S.
Base
Price

Soft Arm Caps

Pneumatic

4535330W	\$ 905	4535330H	\$815	4535330	\$755
-----------------	--------	-----------------	-------	----------------	-------

Pneumatic with Adjustable Seat Depth

4535330DW	\$ 980	4535330DH	\$890	4535330D	\$830
------------------	--------	------------------	-------	-----------------	-------

Upholstered Arm Caps

Pneumatic

4535310W	\$ 955	4535310H	\$865	4535310	\$805
-----------------	--------	-----------------	-------	----------------	-------

Pneumatic with Adjustable Seat Depth

4535310DW	\$1030	4535310DH	\$940	4535310D	\$880
------------------	--------	------------------	-------	-----------------	-------

Without Arms



• Style
Number
• U.S.
Base
Price

Pneumatic

4535300	\$ 640
----------------	--------

Pneumatic with Adjustable Seat Depth

4535300D	\$ 715
-----------------	--------

 **For Canadian Pricing**
Multiply U.S. Price by 1.38.
► See page 1 for details.

Criterion 453 Series High-Back Stools



Standard Includes		Required to Specify
<ul style="list-style-type: none"> ▶ Need help? Product details, page 72 	<ul style="list-style-type: none"> • Back height adjustment • Seat angle adjustment • Variable back stop • Back tension adjustment • Arms, if selected: plastic color to match base • Outer back and outer seat: plastic color • Upholstery: fabric price group 1 • Five-arm base: plastic color • Foot ring: plastic color • 2½"-diameter, hard composition, dual-wheel casters: plastic color to match base 	<ol style="list-style-type: none"> 1 Style number 2 Plastic color number for base, foot ring, outer back, outer seat, arms, and casters 3 Fabric color number for upholstery 4 Options, if selected (see below) <p>▶ See <i>Surface Materials</i>, page 282.</p>

Options	U.S. Price	Required to Specify
Surface Materials Upholstery <ul style="list-style-type: none"> • Fabric price group 1 • Fabric price group 2 • Fabric price group 3 • Fabric price group 4 • Fabric price group 5 • Fabric price group 6 • Fabric price group 7 • Fabric price group 8 • Fabric price group 9 • Fabric price group 10 • Seating vinyl <p><i>Not available on upholstered outer back or upholstered arm cap models.</i></p> <ul style="list-style-type: none"> • Customer's Own Material (COM) • Fire Code Seating (FCS) • Soil-retardant treatment applied to upholstery fabric 	No cost +\$ 20 +\$ 40 +\$ 55 +\$ 70 +\$ 85 +\$100 +\$125 +\$155 +\$175 +\$ 35 +\$ 30 +\$ 50 +\$ 17	Specify fabric color number. Specify fabric color number. Specify fabric color number. Specify fabric color number. Specify fabric color number. Specify fabric color number. Specify fabric color number. Specify fabric color number. Specify fabric color number. Specify fabric color number. Add suffix V to the style number and specify seating vinyl color number. ▶ See <i>Surface Materials Reference Manual</i> to specify. Add suffix F to the style number. Specify <i>with soil-retardant treatment</i> . Add suffix B to the style number. Specify <i>with 9201 Polished Chrome foot ring</i> .
Fully upholstered <ul style="list-style-type: none"> • Outer back 	+\$ 50	Add suffix B to the style number.
Height-adjustable foot ring <ul style="list-style-type: none"> • Polished Chrome foot ring 	+\$ 29	Specify <i>with 9201 Polished Chrome foot ring</i> .
Casters <ul style="list-style-type: none"> • Soft, dual-wheel casters for use on hard floors 	+\$ 18	Specify <i>with soft casters</i> .
Glides <ul style="list-style-type: none"> • Plastic glide with stainless steel cap 	No cost	Specify <i>with GLD453</i> .

Tip: Always add suffixes in alphabetical order when specifying options to Criterion seating.

Tip: Fire Code Seating (FCS) option is available only on models with both adjustable seat depth (**D** suffix) and 6205 Black plastic components.
 ▶ See pages 289–290 for upholstery fabric choices.

Specification Information

Height-, Width-, and Pivot-Adjustable Arms



• Style Number
 • U.S. Base Price

▶ Detailed dimensions, page 76



For Canadian Pricing
 Multiply U.S. Price by 1.38.
 ▶ See page 1 for details.

Soft Arm Caps

Pneumatic

4537331P \$1096

Pneumatic with Adjustable Seat Depth

4537331DP \$1171

► Specification Information, continued

Specification Information

Height- and Width-Adjustable Arms



• **Style Number**
• **U.S. Base Price**

Height-Adjustable Arms



• **Style Number**
• **U.S. Base Price**

Fixed-Height Arms



• **Style Number**
• **U.S. Base Price**

Soft Arm Caps

Pneumatic

4537331W	\$1136	4537331H	\$1046	4537331	\$ 986
-----------------	--------	-----------------	--------	----------------	--------

Pneumatic with Adjustable Seat Depth

4537331DW	\$1211	4537331DH	\$1121	4537331D	\$1061
------------------	--------	------------------	--------	-----------------	--------

Upholstered Arm Caps

Pneumatic

4537311W	\$1186	4537311H	\$1096	4537311	\$1036
-----------------	--------	-----------------	--------	----------------	--------

Pneumatic with Adjustable Seat Depth

4537311DW	\$1261	4537311DH	\$1171	4537311D	\$1111
------------------	--------	------------------	--------	-----------------	--------

Without Arms

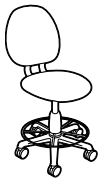

• **Style Number**
• **U.S. Base Price**

Pneumatic

4537301	\$ 871
----------------	--------

Pneumatic with Adjustable Seat Depth

4537301D	\$ 946
-----------------	--------

 **For Canadian Pricing**
Multiply U.S. Price by 1.38.
► See page 1 for details.

Criterion 453 Series Mid-Back Stools



	Standard Includes	Required to Specify
▶ Need help? Product details, page 72	<ul style="list-style-type: none"> • Back height adjustment • Seat angle adjustment • Variable back stop • Back tension adjustment • Arms, if selected: plastic color to match base • Outer back and outer seat: plastic color • Upholstery: fabric price group 1 • Five-arm base: plastic color • Foot ring: plastic color • 2½"-diameter, hard composition, dual-wheel casters: plastic color to match base 	1 Style number 2 Plastic color number for base, foot ring, outer back, outer seat, arms, and casters 3 Fabric color number for upholstery 4 Options, if selected (see below) ▶ See <i>Surface Materials</i> , page 282.

Tip: Always add suffixes in alphabetical order when specifying options to Criterion seating.

Tip: Fire Code Seating (FCS) option is available only on models with both adjustable seat depth (**D** suffix) and 6205 Black plastic components.
▶ See pages 289–290 for upholstery fabric choices.

	Options	U.S. Price	Required to Specify
Surface Materials	Upholstery		
	• Fabric price group 1	No cost	Specify fabric color number.
	• Fabric price group 2	+\$ 20	Specify fabric color number.
	• Fabric price group 3	+\$ 40	Specify fabric color number.
	• Fabric price group 4	+\$ 55	Specify fabric color number.
	• Fabric price group 5	+\$ 70	Specify fabric color number.
	• Fabric price group 6	+\$ 85	Specify fabric color number.
	• Fabric price group 7	+\$100	Specify fabric color number.
	• Fabric price group 8	+\$125	Specify fabric color number.
	• Fabric price group 9	+\$155	Specify fabric color number.
• Fabric price group 10	+\$175	Specify fabric color number.	
• Seating vinyl	+\$ 35	Add suffix V to the style number and specify seating vinyl color number.	
	<i>Not available on upholstered outer back or upholstered arm cap models.</i>		
	• Customer's Own Material (COM)	+\$ 30	▶ See <i>Surface Materials Reference Manual</i> to specify.
	• Fire Code Seating (FCS)	+\$ 50	Add suffix F to the style number.
	• Soil-retardant treatment applied to upholstery fabric	+\$ 17	Specify <i>with soil-retardant treatment</i> .
	Fully upholstered		
	• Outer back	+\$ 50	Add suffix B to the style number.
	Height-adjustable foot ring		
	• Polished Chrome foot ring	+\$ 29	Specify <i>with 9201 Polished Chrome foot ring</i> .
Casters	• Soft, dual-wheel casters for use on hard floors	+\$ 18	Specify <i>with soft casters</i> .
Glides	• Plastic glide with stainless steel cap	No cost	Specify <i>with GLD453</i> .

Specification Information

Height-, Width-, and Pivot-Adjustable Arms



• Style Number
• U.S. Base Price

▶ Detailed dimensions, page 76



For Canadian Pricing
Multiply U.S. Price by 1.38.
▶ See page 1 for details.

Soft Arm Caps

Pneumatic

4537330P \$1052

Pneumatic with Adjustable Seat Depth

4537330DP \$1127

► Specification Information, continued

Specification Information

Height- and Width-Adjustable Arms



• **Style Number**
• **U.S. Base Price**

Height-Adjustable Arms



• **Style Number**
• **U.S. Base Price**

Fixed-Height Arms



• **Style Number**
• **U.S. Base Price**

Soft Arm Caps

Pneumatic

4537330W	\$1092	4537330H	\$1002	4537330	\$ 942
-----------------	--------	-----------------	--------	----------------	--------

Pneumatic with Adjustable Seat Depth

4537330DW	\$1167	4537330DH	\$1077	4537330D	\$1017
------------------	--------	------------------	--------	-----------------	--------

Upholstered Arm Caps

Pneumatic

4537310W	\$1142	4537310H	\$1052	4537310	\$ 992
-----------------	--------	-----------------	--------	----------------	--------

Pneumatic with Adjustable Seat Depth

4537310DW	\$1217	4537310DH	\$1127	4537310D	\$1067
------------------	--------	------------------	--------	-----------------	--------

Without Arms

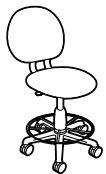

• **Style Number**
• **U.S. Base Price**

Pneumatic

4537300	\$ 827
----------------	--------

Pneumatic with Adjustable Seat Depth

4537300D	\$ 902
-----------------	--------



For Canadian Pricing
Multiply U.S. Price by 1.38.
► See page 1 for details.

Criterion Plus 453 Series High-Back Work Chairs



Tip: Criterion Plus is available with a fully-upholstered outer back only.

Tip: The Criterion Plus models are not available with vinyl upholstery.

Tip: Height-, width-, and pivot-adjustable arms are not available on Criterion Plus.

Tip: Fire Code Seating (FCS) option is available with certain upholstery fabric choices only.
▶ Pages 289–290

Standard Includes		Required to Specify
▶ Need help? Product details, page 72	<ul style="list-style-type: none"> • Back height adjustment • Seat angle adjustment • Manual seat depth adjustment • Back tension adjustment • Upright back lock • Arms, if selected: plastic color to match base • Upholstery: fabric price group 1 • Outer back: upholstery • Outer seat: plastic color • Five-arm base: plastic color • 2½"-diameter, hard composition, dual-wheel casters: plastic color to match base 	<ol style="list-style-type: none"> 1 Style number 2 Plastic color number for base, outer seat, arms, and casters 3 Fabric color number for upholstery 4 Options, if selected (see below) <p>▶ See <i>Surface Materials</i>, page 282.</p>

Options	U.S. Price	Required to Specify
Surface Materials	Upholstery	
	<ul style="list-style-type: none"> • Fabric price group 1 • Fabric price group 2 • Fabric price group 3 • Fabric price group 4 • Fabric price group 5 • Fabric price group 6 • Fabric price group 7 • Fabric price group 8 • Fabric price group 9 • Fabric price group 10 • Customer's Own Material (COM) • Steelcase leather upholstery • Fire Code Seating (FCS) • Soil-retardant treatment applied to upholstery fabric 	<ul style="list-style-type: none"> No cost +\$ 20 +\$ 40 +\$ 55 +\$ 70 +\$ 85 +\$100 +\$125 +\$155 +\$175 +\$ 30 +\$266 +\$ 50 +\$ 17
		<ul style="list-style-type: none"> Specify fabric color number. Specify fabric color number. Specify fabric color number. Specify fabric color number. Specify fabric color number. Specify fabric color number. Specify fabric color number. Specify fabric color number. Specify fabric color number. Specify fabric color number. Specify fabric color number. ▶ See <i>Surface Materials Reference Manual</i> to specify. Specify leather color number. Add suffix F to the style number. Specify <i>with soil-retardant treatment</i>.
Casters	<ul style="list-style-type: none"> • Soft, dual-wheel casters for use on hard floors 	<ul style="list-style-type: none"> +\$ 18 <p>Specify <i>with soft casters</i>.</p>

▶ Detailed dimensions,
page 76



For Canadian Pricing
Multiply U.S. Price by 1.38.
▶ See page 1 for details.

Specification Information

Height- and Width-Adjustable Arms



• Style Number
• U.S. Base Price

Height-Adjustable Arms



• Style Number
• U.S. Base Price

Fixed-Height Arms



• Style Number
• U.S. Base Price

Soft Arm Caps

Pneumatic

4539331BW \$1526

4539331BH \$1476

4539331B \$1416

Upholstered Arm Caps

Pneumatic

4539311BW \$1576

4539311BH \$1526

4539311B \$1466

Without Arms



• Style Number
• U.S. Base Price

Pneumatic

4539301B \$1301



For Canadian Pricing
Multiply U.S. Price by 1.38.
▶ See page 1 for details.



Understanding and Specifying Think 465 Series Work Chairs

Understanding Think 465 Series

Details	90
Dimensions	94

Specifying Think 465 Series

Design Packages

3D Knit on Back with Vibe Standard Upholstery on Seat	96
3D Knit on Back with Vibe Sewn Upholstery on Seat	97

Work Chairs with Arms

3D Knit with Standard Upholstery on Seat	98
3D Knit with Sewn Upholstery on Seat	100
Standard Upholstery	102
Sewn Upholstery	104

Work Chairs, Armless

3D Knit with Standard Upholstery on Seat	106
3D Knit with Sewn Upholstery on Seat	108
Standard Upholstery	110
Sewn Upholstery	112

Work Chairs

Highly adjustable task seating offers maximum personalization for people who sit most of the day performing repetitive tasks. By making a series of simple adjustments, you can customize the chair to your body, preferences, and tasks. These chairs provide continuous, stable, task-oriented comfort, and can be quickly adjusted to support you in upright, forward, and reclining work postures.

- Leap 462 Series
- Leap 464 Series WorkLounge
- Criterion 453 Series
- Think 465 Series
- Drive 461 Series
- Jersey Series
- Sensor 458 Series

Adjustability Features

► See page 11 for a comparison to other chairs. **Think 465 Series**

Mechanisms

Your Power™ ●

Seat Adjustments

Pneumatic height ●

Seat edge flex ●

Seat depth ●

Back Adjustments

Lumbar height ●

Arm Adjustments

Arm depth ●

Arm height ●

Arm pivot ●

Other Features

Soft-wheel casters ●

Think 465 Series

Width-adjustable arms feature will be available in 2005.

Think—the chair with a brain and a conscience.

Back frame and seat shell are plastic.

Arm caps can pivot independently 30° in and 15° out to accommodate individual user preferences.

Lumbar height adjusts over 5" to provide additional lower back support and is available as an option.

Your Preference back control provides four settings for the user's personal preference and work style.

Seat height adjusts within a 5" range with a pneumatic adjustment mechanism. A 4" range is available as an option.

Casters have hard, dual-wheels that roll smoothly on carpets. They are 2½" for increased mobility. Soft, dual-wheel casters are available as an option for use on hard floors or chair mats.

Arm height can adjust independently within a 4" range to help relieve upper back and shoulder fatigue.

Arm depth can retract 3" to allow user to get closer to the worksurface.

Seat edge flex naturally tilts to relieve pressure under the user's thighs.

Seat depth adjusts within a 3" range to accommodate users of varying leg lengths.

Five-arm base is available in plastic or polished aluminum.

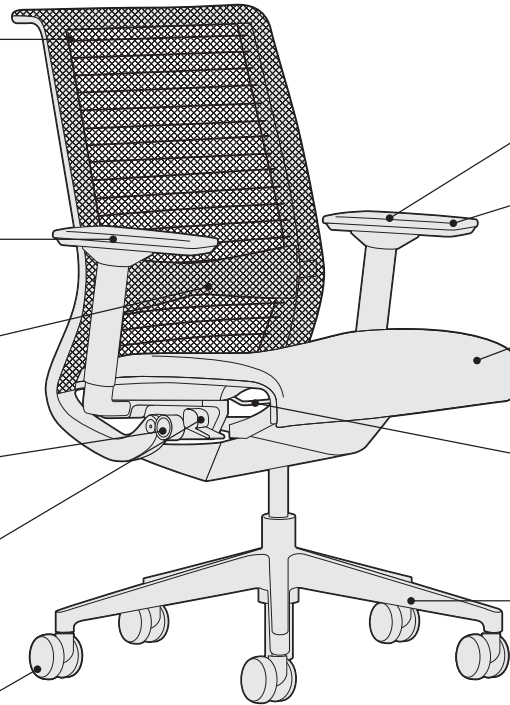

Product Details

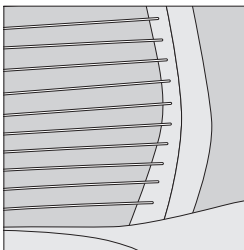

Your Profile™ seat and back have flexors that dynamically and independently follow the movements of the user.

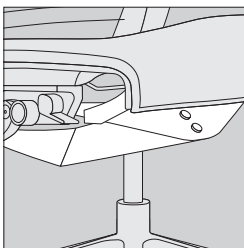

Your Power™ mechanism is weight-activated, with a natural fluid motion that keeps users oriented to their work.



Your Preference™ back control has four settings that allow for the user's personal preference and work style.

Chairs are available without arms, with fixed arms, or with height-depth and pivot-adjustable arms.

Two design packages are available for the Think chair—one highly adjustable package and the other with limited adjustability. 3D Knit is on the back and Designtex Vibe is on the seat. Plastic color choice for frame, seat shell, and base may be specified.

Adjustability instructions are included with every chair.

Adjustment Features

Seat Adjustments

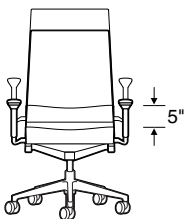

Seat height adjusts pneumatically. To lower, hold handle up while seated. To raise, hold handle up and keep your weight off the chair. Standard range of adjustability is 5" from 16"H to 21"H. A 4" range of adjustability (15"H to 19"H) is available as an option.

Seat edge flexes out of the way relieving pressure under the user's thighs. The combination of seat flexors with a passive front seat edge flex helps properly support the angle of the user's leg and thigh without compromising pelvic support.

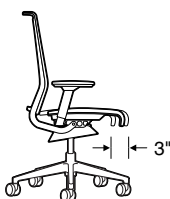

Seat depth adjusts 3" (15"–18") by pulling handle up. Slide seat forward or back to accommodate various leg lengths. Release handle to lock.

Back Adjustments

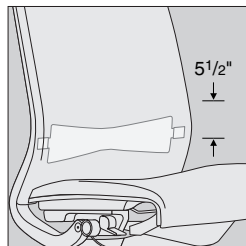

Lumbar height adjusts 5 1/2" (3" to 8 1/2" from seat) by grabbing exposed tabs and sliding the lumbar support up or down. Available as an option on work chairs.



Weight-activated setting

Boosted setting



Mid-stop recline setting

Upright setting

Your Preference™ control has four settings: (1) weight-activated setting; (2) boosted setting that has approximately 20% more resistance than your body is providing; (3) mid-stop recline setting; and (4) an upright setting.

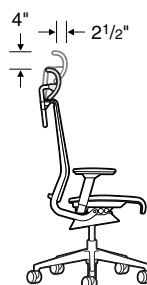

Headrest (option) adjusts 4" vertically and 2 1/2" horizontally (front to back) to support the head and neck of the user in both upright and recline postures. Whether ordered initially or at a later date, the headrest ships in its own carton and must be field-installed.

Arm Adjustments

Height-, pivot-, and depth-adjustable arms come standard on all arm models of chairs. Fixed arms are an option. Also available armless.

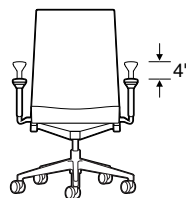

Arm height adjusts independently within a range of 4" (7"–11" from the seat). Push button on outside and under arm cap in while moving arms up or down. Releasing buttons locks arms in position.

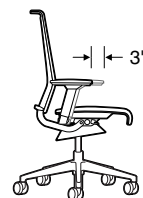

Arm depth adjusts by sliding armcaps back 3" and locking them into position. The spring-loaded mechanism allows for simple and easy armcap retrieval. Armcaps adjust independently within a 3" range.

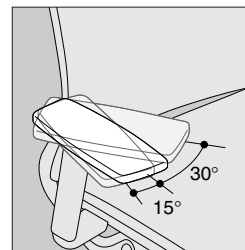

Arms pivot independently within a 45° range, 30° in and 15° out. *Tip: Arms may be tool-adjusted inward 1" to accommodate the user's preference.*

Other Features

Soft-wheel casters for hard floors are available for specific applications.

Surface Materials

▶ See surface materials on page 282 for specific availability or refer to the *Surface Materials Reference Manual* for further information.

Upholstery

- Fabric
- Fabric with soil-retardant treatment (option)
- 3D Knit (back only)
- Leather
- Vinyl

Hard components

(frame, seat shell, base, and arm uprights)

- 6205 Black
- 6694 Slate

Polished aluminum base

is standard on some models.

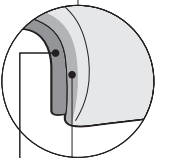

Foundation fabric

Plastic seat shell

On standard-upholstery, the foundation fabric (which is a default of the specified plastic color) is partially visible on the sides of the seat and back cushions.

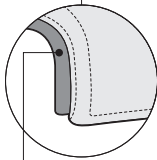

Plastic seat shell

On sewn-upholstery, the upholstery specified on the seat and back is also found on the sides of the seat and back cushions with a boxed stitch detail. Leather and vinyl require sewn upholstery. Fabric can be specified with standard or sewn upholstery.

All Steelcase seating with standard upholstery fabrics complies with requirements of the BIFMA First Generation Voluntary Upholstered Furniture Flammability Standard, as well as the State of California Technical Bulletin 117. All standard seating is labeled to be in compliance with California TB117.

Programs & Services

▶ See the *Surface Materials Reference Manual* for further detail about programs and services offered for seating.

The Customer's Own Material (COM) Program

offers the opportunity for customers to select fabrics that are not offered through the standard Steelcase surface materials program for use on Steelcase products. Through the COM program, Steelcase will test your materials for application on Steelcase products. Once approved, you can place your order. Steelcase will facilitate the entire ordering process and give you a production schedule. Steelcase will order the COM fabric directly from the textile manufacturer. For up-to-date information regarding fabric test results for all COM fabrics and details regarding yardage requirements for most Seating lines, visit the COM Web site. To locate the COM Web site:

- Visit www.steelcase.com
- Click on "Knowledge & Design"
- Select "Customer's Own Material"

Soil retardants are treatments that provide long-term soil and stain resistance to a fabric without affecting the shade or the integrity of the fabric. The following Steelcase Textiles are available pre-treated with soil retardant. (You do not need to select the soil-retardant option for these fabrics and incur the \$17 upcharge.)

- Canzoné
- Cavalcade
- Jacks
- Link
- Regis
- Rook
- Roulette
- Skittles
- Spyder
- Sweepstakes

Soil-retardant treatment is available on all other seating fabrics at an additional \$17 U.S. per seating unit. To order this option, please select "Soil-Retardant Treatment" under "Optional Accessories."

For soil-retardant treatment on COMs, please select "Soil-Retardant Treatment" under "Optional Accessories." Minimums or additional yardage may be required. Please contact the vendor directly for specific information.

Extended lead times may be necessary for this service.

Contact your Steelcase Sales Service representative at 1.888.STEELCASE (1.888.783.3522).

Fire Codes

▶ See pages 289–290 for upholstery fabrics available for use with FCS modification.

Steelcase offers Fire Code Seating modification (FCS) on nearly all seating models.

The most rigorous fire codes in the nation have been developed in California, and the Steelcase FCS modification is designed to meet those codes. Fire Code Seating (FCS) indicates that a product is constructed to meet the strict fire code requirements of high public occupancy areas such as theaters, meeting rooms, and lobbies. The FCS standards will meet both the State of California Home Furnishing Technical Bulletin 133 (Cal TB 133) and Boston Fire Code (BFC). Boston adopted the California Home Furnishing Technical Bulletin TB 133 test standard in 1992.

FCS testing for the Think chairs is in process. Results will be published in the next release.

Local codes may have special requirements for upholstery.

Dimensions

▶ Page 94

Resources

Printed Materials

- ▶ Think Product Brochure (04-0011844)
- ▶ Think Environmental Brochure (04-0011852)
- ▶ Think Environmental Product Declaration (EPD) (04-0012421) (PDF only)
- ▶ Think Pocket Sales Card (04-0011847)
- ▶ Think Customer Powerpoint (Slides/Script) (04-0011848)
- ▶ Think Hang Tag (04-0011853)
- ▶ Seating Sales & Dealer Guide (update) (03-0003909)
- ▶ Think National Ad Reprint (04-0011856)

Audiovisual Materials

- ▶ Think Design Story—Video (04-0011845)
- ▶ Think Design Story—DVD (04-0011846)
- ▶ Think Model Sales Presentation—DVD (04-0012577)
- ▶ Think Model Sales Presentation—VHS (04-0012578)
- ▶ Think Model Sales Presentation—audio CD (04-0012579)

Dimensions

Think 465 Series

Features	Overall Depth	Width	Height	Seat Depth	Functional Seat Depth	Seat Width	Seat Height from Floor	Back Width	Back Height from Seat	Lumbar Height from Seat
Think 465 Series										
Arms	22" to 25"	24 ³ / ₄ "	38 ³ / ₄ " to 43 ³ / ₄ "	18"	15" to 18"	19 ¹ / ₄ "	16" to 21" (15" to 19" optional)	19"	22 ³ / ₄ "	3" to 8 ¹ / ₂ "

*Arms may be tool-adjusted inward 1" to accommodate the user's preference.

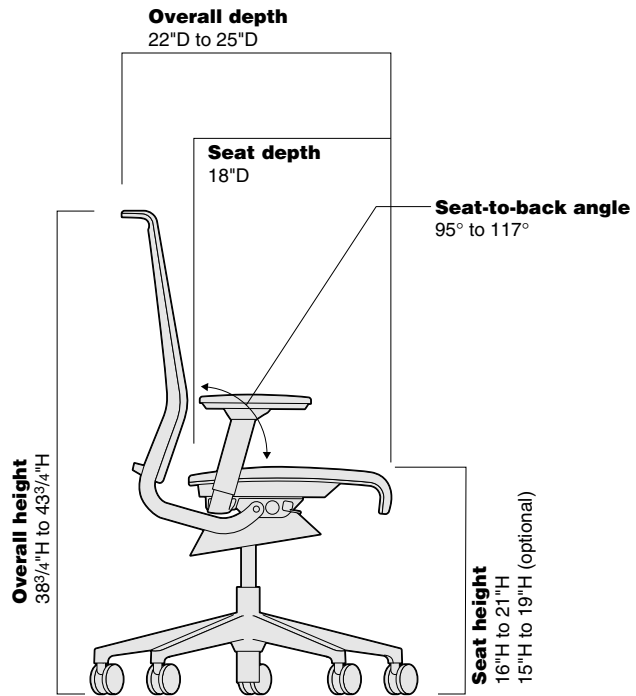
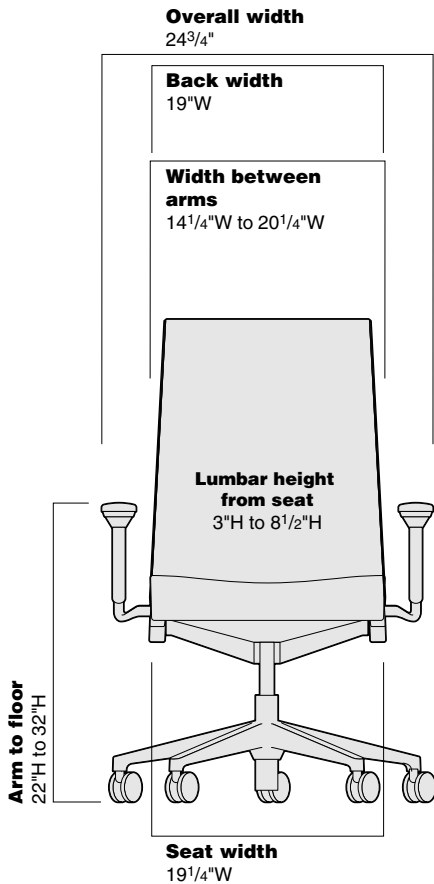

• Width • Between • Adjustable • Arms	• Width • Between • Fixed • Arms	• Arm • to • Floor	• Arm • Height • from • Seat	• Arm • Height • from Seat • for Fixed • Arms	• Arm Cap • Pivot • Range	• Angle • Between • Seat and • Back	• Weight	• Headrest • Height • Adjustment • Range	• Headrest • Depth • Adjustment • Range
14¼" to 20¼"	19¾"	22" to 32"	7" to 11"	9"	45°	95° to 117°	32	4"	2½"

*Arms may be tool-adjusted inward 1" to accommodate the user's preference.

Think 465 Series Design Package Work Chairs

with Arms

3D Knit on Back with Vibe Standard Upholstery on Seat



Standard Includes		Required to Specify
<ul style="list-style-type: none"> ▶ Need help? Product details, page 90 	<ul style="list-style-type: none"> • 5" pneumatic seat-height adjustment (16"–21") • Your Preference™ control • Seat edge flex • Frame, seat shell, and five-arm base: plastic • 3" seat depth adjustment • Height, pivot, depth-adjustable arms • 3D Knit on back and Designtex Vibe on seat • Standard upholstery design on seat • 2½"-diameter, hard-composition, dual-wheel casters: black • 5" lumbar height adjustment 	<ul style="list-style-type: none"> 1 Style number 2 Plastic color for frame, seat shell, and base 3 3D Knit color for back 4 Fabric color number for upholstery on seat ▶ See <i>Surface Materials</i>, page 282.

Specification Information	
• Style Number	• U.S. Price
465THINKS4U	\$950

▶ Detailed dimensions, page 94



For Canadian Pricing
 Multiply U.S. Price by 1.38.
 ▶ See page 1 for details.

Think 465 Series Design Package Work Chairs

Think 465 Series Design
Package Work Chairs

with Arms

3D Knit on Back with Vibe Sewn Upholstery on Seat



Standard Includes		Required to Specify
<ul style="list-style-type: none"> ▶ Need help? Product details, page 90 	<ul style="list-style-type: none"> • 5" pneumatic seat-height adjustment (16"–21") • Your Preference™ control • Seat edge flex • Frame and seat shell: plastic • Polished Aluminum base • 3" seat depth adjustment • Fixed arms • 3D Knit on back and Designtex Vibe on seat • Sewn upholstery design on seat • 2½"-diameter, hard-composition, dual-wheel casters: black 	<ul style="list-style-type: none"> 1 Style number 2 Plastic color for frame and seat shell 3 3D Knit color for back 4 Fabric color number for upholstery on seat ▶ See <i>Surface Materials</i>, page 282.

Specification Information	
• Style Number	• U.S. Price
465THINK	\$950

▶ Detailed dimensions, page 94



For Canadian Pricing
Multiply U.S. Price by 1.38.
▶ See page 1 for details.

Think 465 Series Work Chairs

with Arms

3D Knit with Standard Upholstery on Seat



Standard Includes		Required to Specify
<ul style="list-style-type: none"> ▶ Need help? Product details, page 90 	<ul style="list-style-type: none"> • 5" pneumatic seat-height adjustment (16"–21") • Your Preference™ control • Seat edge flex • Frame, seat shell, and five-arm base • 3" seat depth adjustment • Height, pivot, depth-adjustable arms • 3D Knit on back • Standard upholstery design on seat: fabric price group 1 • 2½"-diameter, hard-composition, dual-wheel casters: black 	<ol style="list-style-type: none"> 1 Style number 2 Plastic color for frame, seat shell, and base 3 3D Knit color for back 4 Fabric color number for upholstery on seat 5 Options, if selected (see below) <ul style="list-style-type: none"> ▶ See <i>Surface Materials</i>, page 282.

Options	U.S. Price	Required to Specify
Surface Materials <ul style="list-style-type: none"> • Upholstery • Fabric price group 1 • Fabric price group 2 • Fabric price group 3 • Fabric price group 4 • Fabric price group 5 • Fabric price group 6 • Fabric price group 7 • Fabric price group 8 • Fabric price group 9 • Fabric price group 10 • Customer's Own Material (COM) • Soil-retardant treatment applied to upholstery fabric 	No cost +\$ 10 +\$ 20 +\$ 28 +\$ 35 +\$ 43 +\$ 50 +\$ 63 +\$ 78 +\$ 88 +\$ 15 +\$ 17	Specify fabric color number. Specify fabric color number. Specify fabric color number. Specify fabric color number. Specify fabric color number. Specify fabric color number. Specify fabric color number. Specify fabric color number. Specify fabric color number. Specify fabric color number. Specify fabric color number. Specify fabric color number. ▶ See <i>Surface Materials Reference Manual</i> . Specify with soil-retardant treatment.
Arms <ul style="list-style-type: none"> • Fixed arms 	-\$100	Specify with fixed arms.
Seat Height <ul style="list-style-type: none"> • 4" pneumatic seat-height adjustment (15"–19") 	No cost	Specify with 4" pneumatic seat-height adjustment.
Lumbar Height <ul style="list-style-type: none"> • 5" travel for additional lumbar support 	+\$ 30	Specify with adjustable lumbar height.
Casters <ul style="list-style-type: none"> • Soft, dual-wheel casters for use on hard floors 	+\$ 18	Specify with soft casters.

Specification Information

Assembled



• Style Number
• U.S. Base Price

Ready to Assemble (Cartoned)



• Style Number
• U.S. Base Price

Plastic Base

Without Headrest

46513100	\$920	46513101	\$920
----------	-------	----------	-------

▶ Specification Information continued on next page

▶ Detailed dimensions, page 94



For Canadian Pricing
Multiply U.S. Price by 1.38.
▶ See page 1 for details.

Think 465 Series Work Chairs

with Arms

3D Knit with Sewn Upholstery on Seat



	Standard Includes	Required to Specify
▶ Need help? Product details, page 90	<ul style="list-style-type: none"> • 5" pneumatic seat-height adjustment (16"–21") • Your Preference™ control • Seat edge flex • Frame, seat shell, and five-arm base • 3" seat depth adjustment • Height, pivot, depth-adjustable arms • 3D Knit on back • Sewn upholstery design on seat: fabric price group 1 • 2½"-diameter, hard-composition, dual-wheel casters: black 	<ol style="list-style-type: none"> 1 Style number 2 Plastic color for frame, seat shell, and base 3 3D Knit color for back 4 Fabric color number for upholstery on seat 5 Options, if selected (see below) <p>▶ See <i>Surface Materials</i>, page 282.</p>

	Options	U.S. Price	Required to Specify
Surface Materials	Upholstery <ul style="list-style-type: none"> • Fabric price group 1 • Fabric price group 2 • Fabric price group 3 • Fabric price group 4 • Fabric price group 5 • Fabric price group 6 • Fabric price group 7 • Fabric price group 8 • Fabric price group 9 • Fabric price group 10 • Steelcase leather upholstery • Customer's Own Material (COM), Customer's Own Vinyl (COV), or Customer's Own Leather (COL) • Soil-retardant treatment applied to upholstery fabric 	No cost +\$ 10 +\$ 20 +\$ 28 +\$ 35 +\$ 43 +\$ 50 +\$ 63 +\$ 78 +\$ 88 +\$140 +\$ 15 +\$ 17	Specify fabric color number. Specify fabric color number. Specify fabric color number. Specify fabric color number. Specify fabric color number. Specify fabric color number. Specify fabric color number. Specify fabric color number. Specify fabric color number. Specify fabric color number. Specify leather color number. ▶ See <i>Surface Materials Reference Manual</i> . Specify with soil-retardant treatment.
Arms	<ul style="list-style-type: none"> • Fixed arms 	–\$100	Specify with fixed arms.
Seat Height	<ul style="list-style-type: none"> • 4" pneumatic seat-height adjustment (15"–19") 	No cost	Specify with 4" pneumatic seat-height adjustment.
Lumbar Height	<ul style="list-style-type: none"> • 5" travel for additional lumbar support 	+\$ 30	Specify with adjustable lumbar height.
Casters	<ul style="list-style-type: none"> • Soft, dual-wheel casters for use on hard floors 	+\$ 18	Specify with soft casters.

Specification Information

Assembled



• Style Number
• U.S. Base Price

Ready to Assemble (Cartoned)



• Style Number
• U.S. Base Price

Plastic Base

Without Headrest

46512100	\$950	46512101	\$950
-----------------	-------	-----------------	-------

▶ Specification Information continued on next page

▶ Detailed dimensions, page 94



For Canadian Pricing
Multiply U.S. Price by 1.38.
▶ See page 1 for details.

Specification Information

Assembled



• **Style
Number**
.....
.....
.....

• **U.S.
Base
Price**
.....
.....
.....

Ready to Assemble (Cartoned)



• **Style
Number**
.....
.....
.....

• **U.S.
Base
Price**
.....
.....
.....

Plastic Base

With Headrest

46512110 \$1100

.....
.....
.....

46512111 \$1100

.....
.....
.....

Assembled



• **Style
Number**
.....
.....
.....

• **U.S.
Base
Price**
.....
.....
.....

Ready to Assemble (Cartoned)



• **Style
Number**
.....
.....
.....

• **U.S.
Base
Price**
.....
.....
.....

Aluminum Base

Without Headrest

46522100 \$1050

.....
.....
.....

46522101 \$1050

.....
.....
.....

Assembled



• **Style
Number**
.....
.....
.....

• **U.S.
Base
Price**
.....
.....
.....

Ready to Assemble (Cartoned)



• **Style
Number**
.....
.....
.....

• **U.S.
Base
Price**
.....
.....
.....

Aluminum Base

With Headrest

46522110 \$1200

.....
.....
.....

46522111 \$1200

.....
.....
.....

Think 465 Series



For Canadian Pricing
Multiply U.S. Price by 1.38.
▶ See page 1 for details.

Think 465 Series Work Chairs



with Arms
Standard Upholstery



Standard Includes		Required to Specify
<ul style="list-style-type: none"> ▶ Need help? Product details, page 90 	<ul style="list-style-type: none"> • 5" pneumatic seat-height adjustment (16"–21") • Your Preference™ control • Seat edge flex • Frame, seat shell, and five-arm base • 3" seat depth adjustment • Height, pivot, depth-adjustable arms • Standard upholstery design: fabric price group 1 • 2½"-diameter, hard-composition, dual-wheel casters: black 	<ol style="list-style-type: none"> 1 Style number 2 Plastic color for frame, seat shell, and base 3 Fabric color number for upholstery on seat and back 4 Options, if selected (see below) <ul style="list-style-type: none"> ▶ See <i>Surface Materials</i>, page 282.

Options	U.S. Price	Required to Specify
Surface Materials Upholstery <ul style="list-style-type: none"> • Fabric price group 1 • Fabric price group 2 • Fabric price group 3 • Fabric price group 4 • Fabric price group 5 • Fabric price group 6 • Fabric price group 7 • Fabric price group 8 • Fabric price group 9 • Fabric price group 10 • Customer's Own Material (COM) • Soil-retardant treatment applied to upholstery fabric 	<ul style="list-style-type: none"> No cost +\$ 20 +\$ 40 +\$ 55 +\$ 70 +\$ 85 +\$100 +\$125 +\$155 +\$175 +\$ 30 +\$ 17 	<ul style="list-style-type: none"> Specify fabric color number. Specify fabric color number. Specify fabric color number. Specify fabric color number. Specify fabric color number. Specify fabric color number. Specify fabric color number. Specify fabric color number. Specify fabric color number. Specify fabric color number. ▶ See <i>Surface Materials Reference Manual</i>. Specify with soil-retardant treatment.
Arms <ul style="list-style-type: none"> • Fixed arms 	<ul style="list-style-type: none"> –\$100 	<ul style="list-style-type: none"> Specify with fixed arms.
Seat Height <ul style="list-style-type: none"> • 4" pneumatic seat-height adjustment (15"–19") 	<ul style="list-style-type: none"> No cost 	<ul style="list-style-type: none"> Specify with 4" pneumatic seat-height adjustment.
Lumbar Height <ul style="list-style-type: none"> • 5" travel for additional lumbar support 	<ul style="list-style-type: none"> +\$ 30 	<ul style="list-style-type: none"> Specify with adjustable lumbar height.
Casters <ul style="list-style-type: none"> • Soft, dual-wheel casters for use on hard floors 	<ul style="list-style-type: none"> +\$ 18 	<ul style="list-style-type: none"> Specify with soft casters.

Specification Information

Assembled		Ready to Assemble (Cartoned)	
			
• Style Number	• U.S. Base Price	• Style Number	• U.S. Base Price
.....

Plastic Base

Without Headrest			
46510100	\$880	46510101	\$880
.....

▶ Specification Information continued on next page

▶ Detailed dimensions, page 94



For Canadian Pricing
Multiply U.S. Price by 1.38.
▶ See page 1 for details.

Specification Information

Assembled



• **Style
Number**
.....
.....
.....

• **U.S.
Base
Price**
.....
.....
.....

Ready to Assemble (Cartoned)



• **Style
Number**
.....
.....
.....

• **U.S.
Base
Price**
.....
.....
.....

Plastic Base

With Headrest

46510110 \$1030
.....
.....

46510111 \$1030
.....
.....

Assembled



• **Style
Number**
.....
.....
.....

• **U.S.
Base
Price**
.....
.....
.....

Ready to Assemble (Cartoned)



• **Style
Number**
.....
.....
.....

• **U.S.
Base
Price**
.....
.....
.....

Aluminum Base

Without Headrest

46520100 \$ 980
.....
.....

46520101 \$ 980
.....
.....

Assembled



• **Style
Number**
.....
.....
.....

• **U.S.
Base
Price**
.....
.....
.....

Ready to Assemble (Cartoned)



• **Style
Number**
.....
.....
.....

• **U.S.
Base
Price**
.....
.....
.....

Aluminum Base

With Headrest

46520110 \$1130
.....
.....

46520111 \$1130
.....
.....

Think 465 Series



For Canadian Pricing
Multiply U.S. Price by 1.38.
▶ See page 1 for details.

Think 465 Series Work Chairs

with Arms
Sewn Upholstery



Standard Includes		Required to Specify
<ul style="list-style-type: none"> ▶ Need help? Product details, page 90 	<ul style="list-style-type: none"> • 5" pneumatic seat-height adjustment (16"–21") • Your Preference™ control • Seat edge flex • Frame, seat shell, and five-arm base • 3" seat depth adjustment • Height, pivot, depth-adjustable arms • Sewn upholstery design: fabric price group 1 • 2½"-diameter, hard-composition, dual-wheel casters: black 	<ol style="list-style-type: none"> 1 Style number 2 Plastic color for frame, seat shell, outer back, and base 3 Fabric color number for upholstery on seat and back 4 Options, if selected (see below) <ul style="list-style-type: none"> ▶ See <i>Surface Materials</i>, page 282.

Options	U.S. Price	Required to Specify						
<table border="0"> <tr> <td>Surface Materials</td> <td>Upholstery</td> <td></td> </tr> <tr> <td></td> <td> <ul style="list-style-type: none"> • Fabric price group 1 • Fabric price group 2 • Fabric price group 3 • Fabric price group 4 • Fabric price group 5 • Fabric price group 6 • Fabric price group 7 • Fabric price group 8 • Fabric price group 9 • Fabric price group 10 • Steelcase leather upholstery • Customer's Own Material (COM), Customer's Own Vinyl (COV), or Customer's Own Leather (COL) • Soil-retardant treatment applied to upholstery fabric </td> <td> <ul style="list-style-type: none"> No cost +\$ 20 +\$ 40 +\$ 55 +\$ 70 +\$ 85 +\$100 +\$125 +\$155 +\$175 +\$275 +\$ 30 +\$ 17 </td> </tr> </table>	Surface Materials	Upholstery			<ul style="list-style-type: none"> • Fabric price group 1 • Fabric price group 2 • Fabric price group 3 • Fabric price group 4 • Fabric price group 5 • Fabric price group 6 • Fabric price group 7 • Fabric price group 8 • Fabric price group 9 • Fabric price group 10 • Steelcase leather upholstery • Customer's Own Material (COM), Customer's Own Vinyl (COV), or Customer's Own Leather (COL) • Soil-retardant treatment applied to upholstery fabric 	<ul style="list-style-type: none"> No cost +\$ 20 +\$ 40 +\$ 55 +\$ 70 +\$ 85 +\$100 +\$125 +\$155 +\$175 +\$275 +\$ 30 +\$ 17 		<ul style="list-style-type: none"> Specify fabric color number. Specify fabric color number. Specify fabric color number. Specify fabric color number. Specify fabric color number. Specify fabric color number. Specify fabric color number. Specify fabric color number. Specify fabric color number. Specify fabric color number. Specify leather color number. ▶ See <i>Surface Materials Reference Manual</i>. Specify with soil-retardant treatment.
Surface Materials	Upholstery							
	<ul style="list-style-type: none"> • Fabric price group 1 • Fabric price group 2 • Fabric price group 3 • Fabric price group 4 • Fabric price group 5 • Fabric price group 6 • Fabric price group 7 • Fabric price group 8 • Fabric price group 9 • Fabric price group 10 • Steelcase leather upholstery • Customer's Own Material (COM), Customer's Own Vinyl (COV), or Customer's Own Leather (COL) • Soil-retardant treatment applied to upholstery fabric 	<ul style="list-style-type: none"> No cost +\$ 20 +\$ 40 +\$ 55 +\$ 70 +\$ 85 +\$100 +\$125 +\$155 +\$175 +\$275 +\$ 30 +\$ 17 						
Arms	<ul style="list-style-type: none"> • Fixed arms 	–\$100	Specify with fixed arms.					
Seat Height	<ul style="list-style-type: none"> • 4" pneumatic seat-height adjustment (15"–19") 	No cost	Specify with 4" pneumatic seat-height adjustment.					
Lumbar Height	<ul style="list-style-type: none"> • 5" travel for additional lumbar support 	+\$ 30	Specify with adjustable lumbar height.					
Casters	<ul style="list-style-type: none"> • Soft, dual-wheel casters for use on hard floors 	+\$ 18	Specify with soft casters.					

Specification Information

Assembled



• Style Number
• U.S. Base Price

Ready to Assemble (Cartoned)



• Style Number
• U.S. Base Price

Plastic Base

Without Headrest

46511100	\$940	46511101	\$940
-----------------	-------	-----------------	-------

▶ Specification Information continued on next page

▶ Detailed dimensions, page 94



For Canadian Pricing
Multiply U.S. Price by 1.38.
▶ See page 1 for details.

Specification Information

Assembled



• **Style Number**
.....
.....
.....

• **U.S. Base Price**
.....
.....
.....

Ready to Assemble (Cartoned)



• **Style Number**
.....
.....
.....

• **U.S. Base Price**
.....
.....
.....

Plastic Base

With Headrest

46511110 \$1090
.....
.....

46511111 \$1090
.....
.....

Assembled



• **Style Number**
.....
.....
.....

• **U.S. Base Price**
.....
.....
.....

Ready to Assemble (Cartoned)



• **Style Number**
.....
.....
.....

• **U.S. Base Price**
.....
.....
.....

Aluminum Base

Without Headrest

46521100 \$1040
.....
.....

46521101 \$1040
.....
.....

Assembled



• **Style Number**
.....
.....
.....

• **U.S. Base Price**
.....
.....
.....

Ready to Assemble (Cartoned)



• **Style Number**
.....
.....
.....

• **U.S. Base Price**
.....
.....
.....

Aluminum Base

With Headrest

46521110 \$1190
.....
.....

46521111 \$1190
.....
.....

Think 465 Series



For Canadian Pricing
Multiply U.S. Price by 1.38.
▶ See page 1 for details.

Think 465 Series Work Chairs

Armless



3D Knit with Standard Upholstery on Seat



Standard Includes		Required to Specify
<ul style="list-style-type: none"> ▶ Need help? Product details, page 90 	<ul style="list-style-type: none"> • 5" pneumatic seat-height adjustment (16"–21") • Your Preference™ control • Seat edge flex • Frame, seat shell, and five-arm base • 3" seat depth adjustment • 3D Knit on back • Standard upholstery design on seat: fabric price group 1 • 2½"-diameter, hard-composition, dual-wheel casters: black 	<ol style="list-style-type: none"> 1 Style number 2 Plastic color for frame, seat shell, and base 3 3D Knit color for back 4 Fabric color number for upholstery on seat 5 Options, if selected (see below) <ul style="list-style-type: none"> ▶ See <i>Surface Materials</i>, page 282.

Options	U.S. Price	Required to Specify
Surface Materials Upholstery <ul style="list-style-type: none"> • Fabric price group 1 • Fabric price group 2 • Fabric price group 3 • Fabric price group 4 • Fabric price group 5 • Fabric price group 6 • Fabric price group 7 • Fabric price group 8 • Fabric price group 9 • Fabric price group 10 • Customer's Own Material (COM) • Soil-retardant treatment applied to upholstery fabric 	No cost +\$10 +\$20 +\$28 +\$35 +\$43 +\$50 +\$63 +\$78 +\$88 +\$15 +\$17	Specify fabric color number. Specify fabric color number. Specify fabric color number. Specify fabric color number. Specify fabric color number. Specify fabric color number. Specify fabric color number. Specify fabric color number. Specify fabric color number. Specify fabric color number. Specify fabric color number. ▶ See <i>Surface Materials Reference Manual</i> . Specify with soil-retardant treatment.
Seat Height <ul style="list-style-type: none"> • 4" pneumatic seat-height adjustment (15"–19") 	No cost	Specify with 4" pneumatic seat-height adjustment.
Lumbar Height <ul style="list-style-type: none"> • 5" travel for additional lumbar support 	+\$30	Specify with adjustable lumbar height.
Casters <ul style="list-style-type: none"> • Soft, dual-wheel casters for use on hard floors 	+\$18	Specify with soft casters.

Specification Information

Assembled		Ready to Assemble (Cartoned)	
			
• Style Number	• U.S. Base Price	• Style Number	• U.S. Base Price

Plastic Base

Without Headrest			
46513000	\$720	46513001	\$720

▶ Specification Information continued on next page

▶ Detailed dimensions, page 94



For Canadian Pricing
 Multiply U.S. Price by 1.38.
 ▶ See page 1 for details.

Think 465 Series Work Chairs



Armless

3D Knit with Sewn Upholstery on Seat



Standard Includes		Required to Specify
<ul style="list-style-type: none"> ▶ Need help? Product details, page 90 	<ul style="list-style-type: none"> • 5" pneumatic seat-height adjustment (16"–21") • Your Preference™ control • Seat edge flex • Frame, seat shell, and five-arm base • 3" seat depth adjustment • 3D Knit on back • Sewn upholstery design on seat: fabric price group 1 • 2½"-diameter, hard-composition, dual-wheel casters: black 	<ol style="list-style-type: none"> 1 Style number 2 Plastic color for frame, seat shell, and base 3 3D Knit color for back 4 Fabric color number for upholstery on seat 5 Options, if selected (see below) <ul style="list-style-type: none"> ▶ See <i>Surface Materials</i>, page 282.

Options	U.S. Price	Required to Specify						
<table border="0"> <tr> <td>Surface Materials</td> <td>Upholstery</td> <td></td> </tr> <tr> <td></td> <td> <ul style="list-style-type: none"> • Fabric price group 1 • Fabric price group 2 • Fabric price group 3 • Fabric price group 4 • Fabric price group 5 • Fabric price group 6 • Fabric price group 7 • Fabric price group 8 • Fabric price group 9 • Fabric price group 10 • Steelcase leather upholstery • Customer's Own Material (COM), Customer's Own Vinyl (COV), or Customer's Own Leather (COL) • Soil-retardant treatment applied to upholstery fabric </td> <td> <ul style="list-style-type: none"> No cost +\$ 10 +\$ 20 +\$ 28 +\$ 35 +\$ 43 +\$ 50 +\$ 63 +\$ 78 +\$ 88 +\$140 +\$ 15 +\$ 17 </td> </tr> </table>	Surface Materials	Upholstery			<ul style="list-style-type: none"> • Fabric price group 1 • Fabric price group 2 • Fabric price group 3 • Fabric price group 4 • Fabric price group 5 • Fabric price group 6 • Fabric price group 7 • Fabric price group 8 • Fabric price group 9 • Fabric price group 10 • Steelcase leather upholstery • Customer's Own Material (COM), Customer's Own Vinyl (COV), or Customer's Own Leather (COL) • Soil-retardant treatment applied to upholstery fabric 	<ul style="list-style-type: none"> No cost +\$ 10 +\$ 20 +\$ 28 +\$ 35 +\$ 43 +\$ 50 +\$ 63 +\$ 78 +\$ 88 +\$140 +\$ 15 +\$ 17 		<ul style="list-style-type: none"> Specify fabric color number. Specify fabric color number. Specify fabric color number. Specify fabric color number. Specify fabric color number. Specify fabric color number. Specify fabric color number. Specify fabric color number. Specify fabric color number. Specify fabric color number. Specify leather color number. ▶ See <i>Surface Materials Reference Manual</i>. Specify with soil-retardant treatment.
Surface Materials	Upholstery							
	<ul style="list-style-type: none"> • Fabric price group 1 • Fabric price group 2 • Fabric price group 3 • Fabric price group 4 • Fabric price group 5 • Fabric price group 6 • Fabric price group 7 • Fabric price group 8 • Fabric price group 9 • Fabric price group 10 • Steelcase leather upholstery • Customer's Own Material (COM), Customer's Own Vinyl (COV), or Customer's Own Leather (COL) • Soil-retardant treatment applied to upholstery fabric 	<ul style="list-style-type: none"> No cost +\$ 10 +\$ 20 +\$ 28 +\$ 35 +\$ 43 +\$ 50 +\$ 63 +\$ 78 +\$ 88 +\$140 +\$ 15 +\$ 17 						
Seat Height	<ul style="list-style-type: none"> • 4" pneumatic seat-height adjustment (15"–19") 	No cost	Specify with 4" pneumatic seat-height adjustment.					
Lumbar Height	<ul style="list-style-type: none"> • 5" travel for additional lumbar support 	+\$ 30	Specify with adjustable lumbar height.					
Casters	<ul style="list-style-type: none"> • Soft, dual-wheel casters for use on hard floors 	+\$ 18	Specify with soft casters.					

Specification Information			
Assembled		Ready to Assemble (Cartoned)	
			
• Style Number	• U.S. Base Price	• Style Number	• U.S. Base Price

Plastic Base			
Without Headrest			
46512000	\$750	46512001	\$750

▶ Detailed dimensions, page 94

▶ Specification Information continued on next page



For Canadian Pricing
 Multiply U.S. Price by 1.38.
 ▶ See page 1 for details.

Specification Information

Assembled



• **Style Number**
• **U.S. Base Price**

Ready to Assemble (Cartoned)



• **Style Number**
• **U.S. Base Price**

Plastic Base

With Headrest

46512010 \$ 900

46512011 \$ 900

Assembled



• **Style Number**
• **U.S. Base Price**

Ready to Assemble (Cartoned)



• **Style Number**
• **U.S. Base Price**

Aluminum Base

Without Headrest

46522000 \$ 850

46522001 \$ 850

Assembled



• **Style Number**
• **U.S. Base Price**

Ready to Assemble (Cartoned)



• **Style Number**
• **U.S. Base Price**

Aluminum Base

With Headrest

46522010 \$1000

46522011 \$1000

Think 465 Series



For Canadian Pricing
Multiply U.S. Price by 1.38.
▶ See page 1 for details.

Think 465 Series Work Chairs



Armless
Standard Upholstery



Standard Includes		Required to Specify
<ul style="list-style-type: none"> ▶ Need help? Product details, page 90 	<ul style="list-style-type: none"> • 5" pneumatic seat-height adjustment (16"–21") • Your Preference™ control • Seat edge flex • Frame, seat shell, and five-arm base • 3" seat depth adjustment • Standard upholstery design: fabric price group 1 • 2½"-diameter, hard-composition, dual-wheel casters: black 	<ol style="list-style-type: none"> 1 Style number 2 Plastic color for frame, seat shell, and base 3 Fabric color number for upholstery on seat and back 4 Options, if selected (see below) <ul style="list-style-type: none"> ▶ See <i>Surface Materials</i>, page 282.

Options	U.S. Price	Required to Specify
Surface Materials <ul style="list-style-type: none"> • Fabric price group 1 • Fabric price group 2 • Fabric price group 3 • Fabric price group 4 • Fabric price group 5 • Fabric price group 6 • Fabric price group 7 • Fabric price group 8 • Fabric price group 9 • Fabric price group 10 • Customer's Own Material (COM) • Soil-retardant treatment applied to upholstery fabric 	No cost +\$ 20 +\$ 40 +\$ 55 +\$ 70 +\$ 85 +\$100 +\$125 +\$155 +\$175 +\$ 30 +\$ 17	Specify fabric color number. Specify fabric color number. Specify fabric color number. Specify fabric color number. Specify fabric color number. Specify fabric color number. Specify fabric color number. Specify fabric color number. Specify fabric color number. Specify fabric color number. Specify fabric color number. ▶ See <i>Surface Materials Reference Manual</i> . Specify with soil-retardant treatment.
Seat Height <ul style="list-style-type: none"> • 4" pneumatic seat-height adjustment (15"–19") 	No cost	Specify with 4" pneumatic seat-height adjustment.
Lumbar Height <ul style="list-style-type: none"> • 5" travel for additional lumbar support 	+\$ 30	Specify with adjustable lumbar height.
Casters <ul style="list-style-type: none"> • Soft, dual-wheel casters for use on hard floors 	+\$ 18	Specify with soft casters.

Specification Information

Assembled		Ready to Assemble (Cartoned)	
			
• Style Number	• U.S. Base Price	• Style Number	• U.S. Base Price

Plastic Base

Without Headrest			
46510000	\$680	46510001	\$680

▶ Specification Information continued on next page

▶ Detailed dimensions, page 94

For Canadian Pricing
 Multiply U.S. Price by 1.38.
 ▶ See page 1 for details.

Specification Information

Assembled



• Style
Number

• U.S.
Base
Price

Ready to Assemble (Cartoned)



• Style
Number

• U.S.
Base
Price

Plastic Base

With Headrest

46510010 \$830

46510011 \$830

Assembled



• Style
Number

• U.S.
Base
Price

Ready to Assemble (Cartoned)



• Style
Number

• U.S.
Base
Price

Aluminum Base

Without Headrest

46520000 \$780

46520001 \$780

Assembled



• Style
Number

• U.S.
Base
Price

Ready to Assemble (Cartoned)



• Style
Number

• U.S.
Base
Price

Aluminum Base

With Headrest

46520010 \$930

46520011 \$930



For Canadian Pricing
Multiply U.S. Price by 1.38.
▶ See page 1 for details.

Think 465 Series Work Chairs

Armless
Sewn Upholstery



Standard Includes		Required to Specify
<ul style="list-style-type: none"> ▶ Need help? Product details, page 90 	<ul style="list-style-type: none"> • 5" pneumatic seat-height adjustment (16"-21") • Your Preference™ control • Seat edge flex • Frame, seat shell, and five-arm base • 3" seat depth adjustment • Sewn upholstery design: fabric price group 1 • 2½"-diameter, hard-composition, dual-wheel casters: black 	<ol style="list-style-type: none"> 1 Style number 2 Plastic color for frame, seat shell, outer back, and base 3 Fabric color number for upholstery on seat and back 4 Options, if selected (see below) <ul style="list-style-type: none"> ▶ See <i>Surface Materials</i>, page 282.

Options	U.S. Price	Required to Specify
Surface Materials Upholstery <ul style="list-style-type: none"> • Fabric price group 1 • Fabric price group 2 • Fabric price group 3 • Fabric price group 4 • Fabric price group 5 • Fabric price group 6 • Fabric price group 7 • Fabric price group 8 • Fabric price group 9 • Fabric price group 10 • Steelcase leather upholstery • Customer's Own Material (COM), Customer's Own Vinyl (COV), or Customer's Own Leather (COL) • Soil-retardant treatment applied to upholstery fabric 	No cost +\$ 20 +\$ 40 +\$ 55 +\$ 70 +\$ 85 +\$100 +\$125 +\$155 +\$175 +\$275 +\$ 30 +\$ 17	Specify fabric color number. Specify fabric color number. Specify fabric color number. Specify fabric color number. Specify fabric color number. Specify fabric color number. Specify fabric color number. Specify fabric color number. Specify fabric color number. Specify fabric color number. Specify leather color number. ▶ See <i>Surface Materials Reference Manual</i> . Specify with soil-retardant treatment.
Seat Height <ul style="list-style-type: none"> • 4" pneumatic seat-height adjustment (15"-19") 	No cost	Specify with 4" pneumatic seat-height adjustment.
Lumbar Height <ul style="list-style-type: none"> • 5" travel for additional lumbar support 	+\$ 30	Specify with adjustable lumbar height.
Casters <ul style="list-style-type: none"> • Soft, dual-wheel casters for use on hard floors 	+\$ 18	Specify with soft casters.

Specification Information

Assembled



• Style Number
• U.S. Base Price

Ready to Assemble (Cartoned)



• Style Number
• U.S. Base Price

Plastic Base

Without Headrest

46511000	\$740	46511001	\$740
----------	-------	----------	-------

▶ Specification Information continued on next page

▶ Detailed dimensions, page 94



For Canadian Pricing
Multiply U.S. Price by 1.38.
▶ See page 1 for details.

Specification Information

Assembled



• Style
Number

• U.S.
Base
Price

Ready to Assemble (Cartoned)



• Style
Number

• U.S.
Base
Price

Plastic Base

With Headrest

46511010 \$890

46511011 \$890

Assembled



• Style
Number

• U.S.
Base
Price

Ready to Assemble (Cartoned)



• Style
Number

• U.S.
Base
Price

Aluminum Base

Without Headrest

46521000 \$840

46521001 \$840

Assembled



• Style
Number

• U.S.
Base
Price

Ready to Assemble (Cartoned)



• Style
Number

• U.S.
Base
Price

Aluminum Base

With Headrest

46521010 \$990

46521011 \$990

Think 465 Series



For Canadian Pricing
Multiply U.S. Price by 1.38.
▶ See page 1 for details.



Understanding and Specifying Drive 461 Series Work Chairs

Understanding Drive 461 Series

Details	116
Dimensions	120

Specifying Drive 461 Series

Work Chairs	122
-------------	-----

Work Chairs

Highly adjustable task seating offers maximum personalization for people who sit most of the day performing repetitive tasks. By making a series of simple adjustments, you can customize the chair to your body, preferences, and tasks. These chairs provide continuous, stable, task-oriented comfort, and can be quickly adjusted to support you in upright, forward, and reclining work postures.

- Leap 462 Series
- Leap 464 Series
- Criterion 453 Series
- Think 465 Series
- Drive 461 Series
- Jersey Series
- Sensor 458 Series

Adjustability Features

▶ See page 11 for a comparison to other chairs.

Drive 461 Series

Mechanisms

Synchro-tilt	●
--------------	---

Seat Adjustments

Pneumatic height	●
------------------	---

Seat angle	●
------------	---

Seat depth	●
------------	---

Back Adjustments

Lumbar height	●
---------------	---

Back tension	●
--------------	---

Upright back lock	●
-------------------	---

Arm Adjustments

Arm height	●
------------	---

Arm width	●
-----------	---

Arm pivot	●
-----------	---

Drive 461 Series

Drive is high-performance seating for value-driven customers. Intuitive controls, high-comfort ratings, a versatile statement of line, and a wide range of adjustments make it a great solution for anywhere in the office.

Outer back and outer seat is plastic. Fully upholstered outer back is an option.

Lumbar adjusts up and down within a 4" range to help ensure healthful back posture.

Arm height adjusts independently within a 4" range to help relieve upper back and shoulder fatigue.

Face plate is plastic and will match base color.

Upright back lock allows user to lock the back in a full upright position or release it for full-tilt motion.

Casters have hard, dual-wheels that roll smoothly on carpets. Soft, dual-wheel casters are available for use on hard floors or chair mats.

Five-arm base is steel with plastic cap.

Arm width adjusts within a 3" range for each arm to provide forearm support in neutral position for 5th to 95th percentile users.

Arm caps can pivot independently to accommodate user preferences.

Seat depth adjusts within a 3" range and is an option on all models. Adjustment paddle is located on left side of chair.

Seat angle adjusts forward, upright, and reclined to suit user.

Seat height adjusts within a 5" range with a pneumatic adjustment mechanism.

Product Details



Two basic back heights are available—full-back and mid-back. Both are offered with and without arms.

Drive offers multiple arm options.

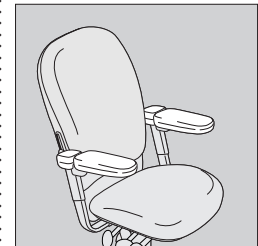

Height- and width-adjustable T-arms

- Height- and width-adjustable T-arms are standard on all chairs with arms.



Independent height-, width-, and pivot-adjustable arms

- Telescoping arms with height, width, and pivot adjustability are an option.

Adjustment Features

Seat Adjustments

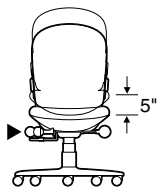

Seat height adjusts pneumatically.

To raise, lift your weight off the seat and pull lever up. To lower chair, remain seated and pull lever up.



Seat angle adjusts

by pulling paddle and shifting your weight to alter seat angle. Release paddle to lock.



Seat depth adjustment.

Lift paddle under left side of seat. Slide seat forward or backward. Release paddle.

Back Adjustments

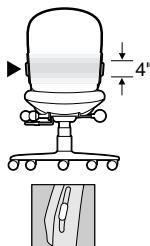

Lumbar adjustment.

Lean forward to slide handle up or down with both hands to desired position.

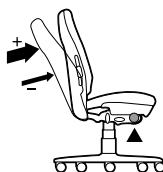

Back tension adjustment.

Turn knob forward to increase tension, backwards to decrease.

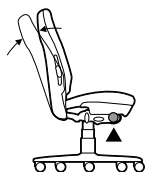

Upright back lock.

To release, lean forward and pull toward back. To lock, lean forward and push toward front.

Arm Adjustments

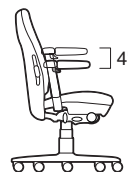

Arm height.

Lift trigger, raise or lower to desired height.

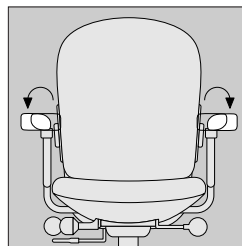

Arm width on standard T-arm.

Grasp arm caps, flip them over.

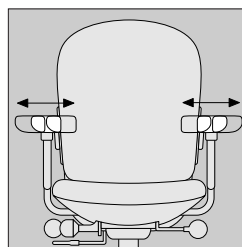

Arm width on rounded telescoping height, width, and pivot arm.

Grasp arm caps and move in or out. Arm will stay where positioned.

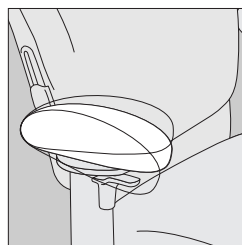

Arms pivot independently. Grasp arm and push from front to left or right.

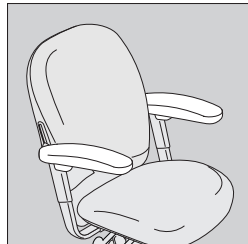

Height-adjustable T-arms

- Height-adjustable T-arms are an option.

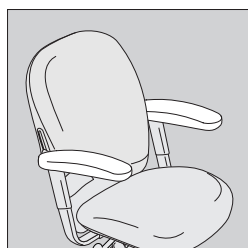

Fixed T-Arms

- Fixed T-Arms are an option.

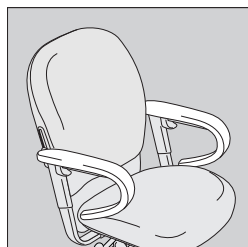

Loop arms

- Height-adjustable loop arms are an option.
- Fixed loop arms are an option.

Surface Materials

► See surface materials on page 282 for specific availability or refer to the *Surface Materials Reference Manual* for further information.

Upholstery

- Fabric
- Fabric with soil-retardant treatment (option)
- Leather

Hard components

(base, arms, plastic arm caps, outer back, outer seat, and face plate)

- Monochromatic color from list of seating plastic color numbers will apply to all hard components.

Outer back and outer seat

- Plastic color to match color of other "hard components"
- Fully upholstered outer back

Arms

- Plastic color arm caps to match the plastic color of the other "hard components"

All Steelcase seating with standard upholstery fabrics

complies with requirements of the BIFMA First Generation Voluntary Upholstered Furniture Flammability Standard, as well as the State of California Technical Bulletin 117. All standard seating is labeled to be in compliance with California TB117.

Programs & Services

▶ See the *Surface Materials Reference Manual* for further detail about programs and services offered for seating.

The Customer's Own Material (COM) Program

offers the opportunity for customers to select fabrics that are not offered through the standard Steelcase surface materials program for use on Steelcase products. Through the COM program, Steelcase will test your materials for application on Steelcase products. Once approved, you can place your order. Steelcase will facilitate the entire ordering process and give you a production schedule. Steelcase will order the COM fabric directly from the textile manufacturer. For up-to-date information regarding fabric test results for all COM fabrics and details regarding yardage requirements for most Seating lines, visit the COM Web site. To locate the COM Web site:

- Visit www.steelcase.com
- Click on "Knowledge & Design"
- Select "Customer's Own Material"

Soil retardants are treatments that provide long-term soil and stain resistance to a fabric without affecting the shade or the integrity of the fabric. The following Steelcase Textiles are available pre-treated with soil retardant. (You do not need to select the soil-retardant option for these fabrics and incur the \$17 upcharge.)

- Canzoné
- Cavalcade
- Jacks
- Link
- Regis
- Rook
- Roulette
- Skittles
- Spyder
- Sweepstakes

Soil-retardant treatment is available on all other seating fabrics at an additional \$17 U.S. per seating unit. To order this option, please select "Soil-Retardant Treatment" under "Optional Accessories."

For soil-retardant treatment on COMs, please select "Soil-Retardant Treatment" under "Optional Accessories." Minimums or additional yardage may be required. Please contact the vendor directly for specific information.

Extended lead times may be necessary for this service.

Contact your Steelcase Sales Service representative at 1.888.STEELCASE (1.888.783.3522).

Fire Codes

▶ See pages 289–290 for upholstery fabrics available for use with FCS modification.

Steelcase offers Fire Code Seating modification (FCS) on nearly all seating models. The most rigorous fire codes in the nation have been developed in California, and the Steelcase FCS modification is designed to meet those codes. Fire Code Seating (FCS) indicates that a product is constructed to meet the strict fire code requirements of high public occupancy areas such as theaters, meeting rooms, and lobbies. The FCS standards will meet both the State of California Home Furnishing Technical Bulletin 133 (Cal TB 133) and Boston Fire Code (BFC). Boston adopted the California Home Furnishing Technical Bulletin TB 133 test standard in 1992.

Local codes may have special requirements for upholstery.

Dimensions

▶ Page 120

Resources

Printed Materials

- ▶ Drive Brochure (S10625)
- ▶ Seating Overview (03-0003368)
- ▶ Drive User Guide (S11264)

Computer Tools

- ▶ Interactive User Guide available on www.steelcase.com
- ▶ Electronic User Disk (S10615)

Dimensions

Drive 461 Series

Features	Overall Depth	Width	Height	Fixed Seat Depth	Adjustable Seat Depth	Seat Width	Seat Height from Floor	Back Width	Back Height from Seat
----------	---------------	-------	--------	------------------	-----------------------	------------	------------------------	------------	-----------------------

Drive 461 Series

Full-Back Work Chairs

Arms	27 ³ / ₈ "	26"	37 ¹ / ₂ "–42 ¹ / ₂ "	16 ³ / ₄ "	16"–19"	20"	15 ¹ / ₂ "–20 ¹ / ₂ "	18 ¹ / ₂ "	23 ¹ / ₂ "
Without Arms	27 ³ / ₈ "	19 ¹ / ₂ "	37 ¹ / ₂ "–42 ¹ / ₂ "	16 ³ / ₄ "	16"–19"	20"	15 ¹ / ₂ "–20 ¹ / ₂ "	18 ¹ / ₂ "	23 ¹ / ₂ "

Mid-Back Work Chairs

Arms	27 ³ / ₈ "	26"	33 ¹ / ₂ "–38 ¹ / ₂ "	16 ³ / ₄ "	16"–19"	20"	15 ¹ / ₂ "–20 ¹ / ₂ "	18 ¹ / ₂ "	19 ¹ / ₂ "
Without Arms	27 ³ / ₈ "	19 ¹ / ₂ "	33 ¹ / ₂ "–38 ¹ / ₂ "	16 ³ / ₄ "	16"–19"	20"	15 ¹ / ₂ "–20 ¹ / ₂ "	18 ¹ / ₂ "	19 ¹ / ₂ "

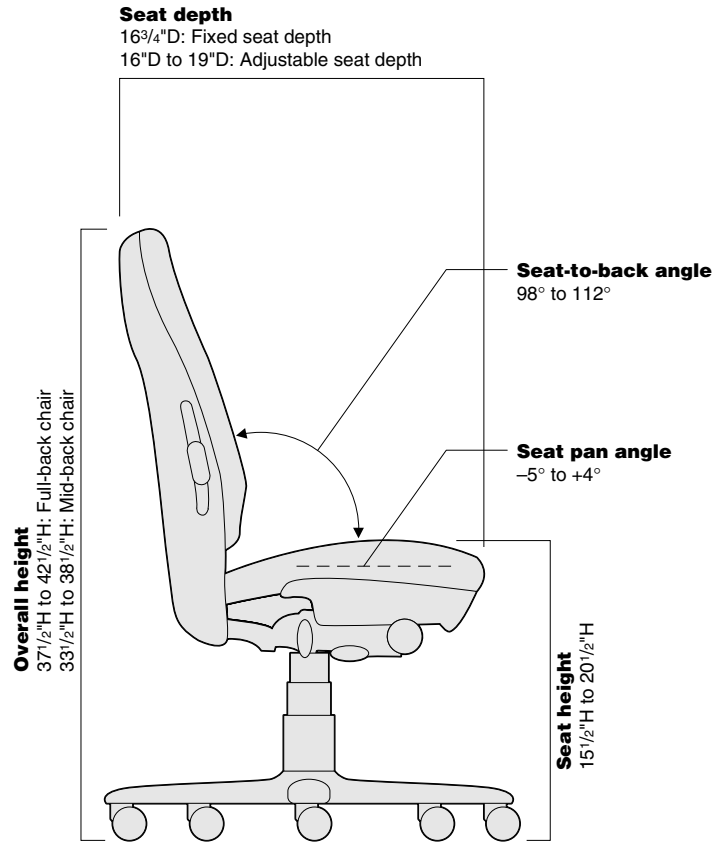
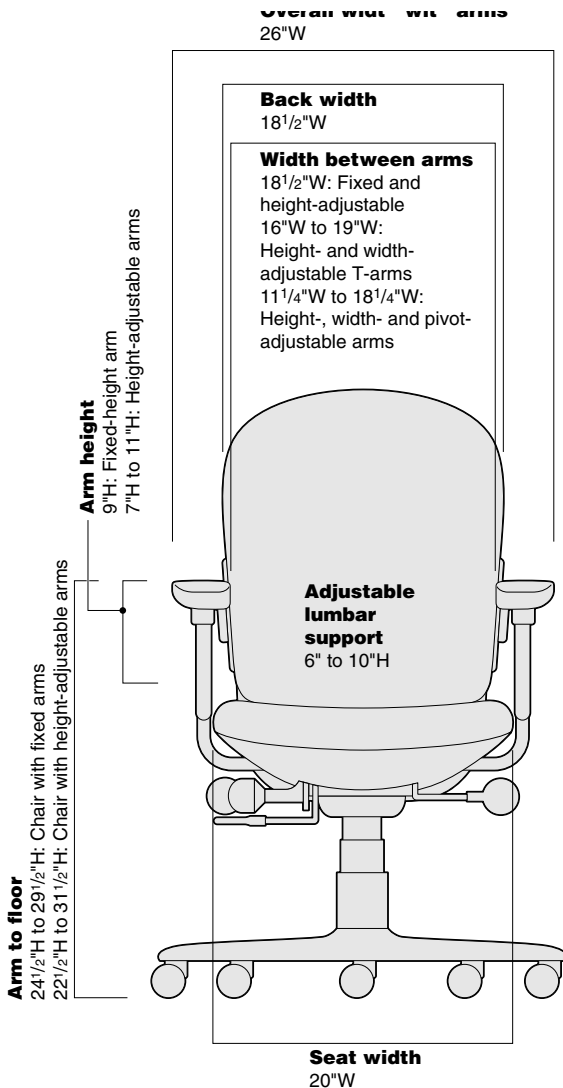

• Back Lumbar Height	• Arm to Floor	• Adjustable Arm Height from Seat	• Fixed Arm Height from Seat	• Width Between Fixed and Height-Adjustable Arms	• Width Between Height-Adjustable T-Arms	• Width Between Height-, Width- and Pivot-Adjustable Arm	• Seat Pan Angle	• Angle Between Seat and Back
Full-Back Work Chairs								
6"-10"	22"-33"	7"-11"	9"	18½"	16"-19"	11¼"-18¼"	-5°-+4°	98°-112°
6"-10"	N.A.	N.A.	N.A.	N.A.	N.A.	N.A.	-5°-+4°	98°-112°
Mid-Back Work Chairs								
6"-10"	22"-33"	7"-11"	9"	18½"	16"-19"	11¼"-18¼"	-5°-+4°	98°-112°
6"-10"	N.A.	N.A.	N.A.	N.A.	N.A.	N.A.	-5°-+4°	98°-112°

Drive 461 Series Work Chairs



	Standard Includes	Required to Specify
▶ Need help? Product details, page 116	<ul style="list-style-type: none"> • Synchro-tilt mechanism • Upright back lock • Lumbar adjustment • 5" seat height range • Pneumatic height adjustment • Height- and width-adjustable T-Arms, if selected: plastic color to match base • Outer back and outer seat: plastic • Upholstery: fabric price group 1 • Five-arm base: plastic color • 2½"-diameter, hard composition, dual-wheel casters: plastic color to match base 	<ol style="list-style-type: none"> 1 Style number 2 Plastic color number for base, outer back, outer seat, arms, and casters 3 Fabric color number for upholstery 4 Options, if selected (see below) <p>▶ See <i>Surface Materials</i>, page 282.</p>

	Options	U.S. Price	Required to Specify
Surface Materials	Upholstery <ul style="list-style-type: none"> • Fabric price group 1 • Fabric price group 2 • Fabric price group 3 • Fabric price group 4 • Fabric price group 5 • Fabric price group 6 • Fabric price group 7 • Fabric price group 8 • Fabric price group 9 • Fabric price group 10 • Customer's Own Material (COM) • Steelcase leather upholstery • Customer's Own Leather (COL) • Fire Code Seating (FCS) • Soil-retardant treatment applied to upholstery fabric 	No cost +\$ 20 +\$ 40 +\$ 55 +\$ 70 +\$ 85 +\$100 +\$125 +\$155 +\$175 +\$ 30 +\$530 +\$299 +\$ 50 +\$ 17	Specify fabric color number. Specify fabric color number. Specify fabric color number. Specify fabric color number. Specify fabric color number. Specify fabric color number. Specify fabric color number. Specify fabric color number. Specify fabric color number. Specify fabric color number. Specify fabric color number. ▶ See <i>Surface Materials Reference Manual</i> to specify. Add suffix S to the style number and specify leather color number for upholstery. Add suffix S to the style number. ▶ See <i>Surface Materials Reference Manual</i> to specify. Add suffix F to style number. Specify <i>with soil-retardant treatment</i> .
	Fully upholstered <ul style="list-style-type: none"> • Fabric fully upholstered outer back • Steelcase leather fully upholstered outer back • Customer's Own Leather (COL) 	+\$125 +\$925 +\$465	Add suffix U to style number. Add suffix SU to the style number and specify leather color number. Add suffix SU to the style number. ▶ See <i>Surface Materials Reference Manual</i> to specify.
	Rounded Arm Caps <ul style="list-style-type: none"> • Independent height-, width-, and pivot-adjustable 	+\$ 30	Specify <i>with height-, width-, and pivot-adjustable arms</i> .
	T-Arms <ul style="list-style-type: none"> • Independent height-adjustable • Fixed height 	-\$ 59 -\$ 91	Specify <i>with height-adjustable T-arms</i> . Specify <i>with fixed T-arms</i> .
	Loop Arms <ul style="list-style-type: none"> • Independent height-adjustable • Fixed height 	-\$ 20 -\$ 91	Specify <i>with height-adjustable loop arms</i> . Specify <i>with fixed loop arms</i> .
	Casters <ul style="list-style-type: none"> • Soft, dual-wheel casters for use on hard floors (2½") 	+\$ 18	Specify <i>with soft casters</i> .

Tip: Always add suffixes in alphabetical order when specifying options to Drive seating.

Tip: Fire Code Seating (FCS) option is available with certain upholstery fabric choices only.
▶ Pages 289–290

▶ Detailed dimensions, page 120



For Canadian Pricing
Multiply U.S. Price by 1.38.
▶ See page 1 for details.

Specification Information

Arms with Soft Arm Caps



• Style
Number

• U.S.
Base
Price

Without Arms



• Style
Number

• U.S.
Base
Price

Full-Back Work Chairs

Back Lock, Seat Angle, Seat Depth

4611411	\$860	4611401	\$690
----------------	-------	----------------	-------

Back Lock, Seat Depth

4611311	\$811	4611301	\$641
----------------	-------	----------------	-------

Back Lock, Seat Angle

4611211	\$810	4611201	\$640
----------------	-------	----------------	-------

Back Lock

4611111	\$761	4611101	\$591
----------------	-------	----------------	-------

Arms with Soft Arm Caps



• Style
Number

• U.S.
Base
Price

Without Arms



• Style
Number

• U.S.
Base
Price

Mid-Back Work Chairs

Back Lock, Seat Angle, Seat Depth

4611410	\$850	4611400	\$680
----------------	-------	----------------	-------

Back Lock, Seat Depth

4611310	\$801	4611300	\$631
----------------	-------	----------------	-------

Back Lock, Seat Angle

4611210	\$800	4611200	\$630
----------------	-------	----------------	-------

Back Lock

4611110	\$751	4611100	\$581
----------------	-------	----------------	-------



For Canadian Pricing
Multiply U.S. Price by 1.38.
▶ See page 1 for details.



Understanding and Specifying Jersey Series Work Chair

Understanding Jersey Series

Details	126
Dimensions	130

Specifying Jersey Series

Work Chairs	132
Multi-Use Chairs	134

Work Chairs

Highly adjustable task seating offers maximum personalization for people who sit most of the day performing repetitive tasks. By making a series of simple adjustments, you can customize the chair to your body, preferences, and tasks. These chairs provide continuous, stable, task-oriented comfort, and can be quickly adjusted to support you in upright, forward, and reclining work postures.

- Leap 462 Series
- Leap 464 Series WorkLounge
- Criterion 453 Series
- Drive 461 Series
- Jersey Series
- Sensor 458 Series

Adjustability Features

▶ See page 11 for a comparison to other chairs.

Jersey Series

Mechanisms

Synchro-tilt	●
--------------	---

Seat Adjustments

Pneumatic height	●
------------------	---

Seat angle	●
------------	---

Seat depth	●
------------	---

Back Adjustments

Back tension	●
--------------	---

Upright back lock	●
-------------------	---

Arm Adjustments

Arm height	●
------------	---

Arm width	●
-----------	---

Arm pivot	●
-----------	---

Jersey Series

Jersey features a double mesh back in a unique ergonomic "S" shape to conform to each user for comfort and support.

Arm height adjusts independently within a 4" range to help relieve upper back and shoulder fatigue.

Arm width adjusts within a 3" range for each arm to provide forearm support in a neutral position.

Arm caps can pivot independently to accommodate user preferences.

Seat height adjusts 4½", from 16" to 20½", with a pneumatic adjustment mechanism.

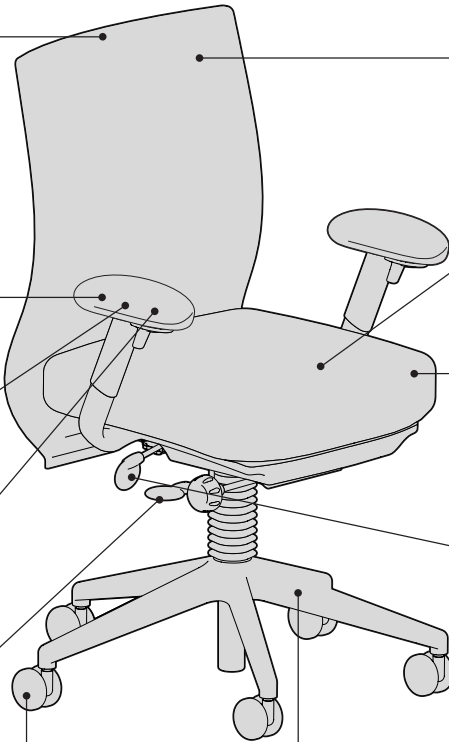

Mesh back is available in 8 colors and is standard on all models. Jersey pullover is optional.

Seat depth adjusts within a 3" range and is an option on all models.

Seat angle adjusts forward, upright, and reclined to suit user.

Upright back lock allows user to lock the back in a full upright position or release it for full-tilt motion.

Five-arm base is plastic on 6205 Black frame models. Base is aluminum on 4799 Platinum models.

Casters have hard, dual-wheels that roll smoothly on carpets. Soft, dual-wheel casters are available for use on hard floors or chair mats.

Product Details



Jersey work chairs are available armless, with fixed arms, with height and maintenance width-adjustable arms, and with height-, width-, and pivot-adjustable arms.

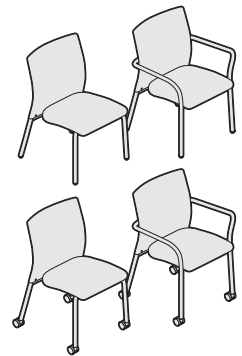

Multi-use chairs are available with or without arms and with or without casters.

Adjustment Features

Seat Adjustments

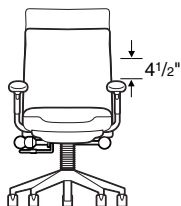

Seat height adjusts pneumatically.

To raise chair, lift body weight up, and pull lever up. To lower chair, remain seated and pull lever up.



Seat angle adjustment.

Pull lever back and hold, shift seat to desired angle, and release lever to lock.

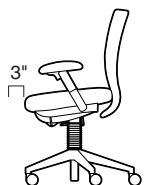

Seat depth adjustment.

Pull lever forward and hold, shift seat forward or back, and release lever to lock.

Back Adjustments



Back tension adjustment.

To decrease tension, turn counterclockwise. To increase tension, turn clockwise.



Upright back lock.

To release, lean forward and pull toward back. To lock, lean forward and push toward front.

Arm Adjustments

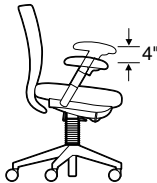

Arm height.

Pull trigger up and hold, pull arm up or push down, and release trigger to lock

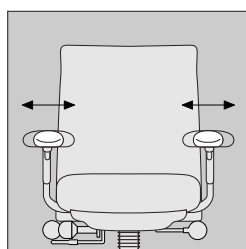

Arm width on rounded telescoping height, width, and pivot arm.

Grasp arm caps and move in or out. Arm will stay where positioned.

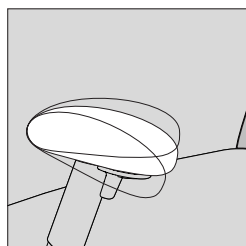

Arms pivot independently. Grasp arm and push from front to left or right.

Maintenance arm width adjustment.

Loosen and remove screws, slide arm bracket in. Replace and tighten screws.

Surface Materials

▶ See surface materials on page 282 for specific availability or refer to the *Surface Materials Reference Manual* for further information.

Upholstery

- Fabric or leather on seat
- Mesh on back standard
- Jersey pullover on back optional

Hard components

(base, arms, plastic arm caps, outer seat)

- Black

Platinum frame

(base and arm uprights) available as an option

Arms

- Black

All Steelcase seating with standard upholstery fabrics

complies with requirements of the BIFMA First Generation Voluntary Upholstered Furniture Flammability Standard, as well as the State of California Technical Bulletin 117. All standard seating is labeled to be in compliance with California TB117.

Programs & Services

▶ See the *Surface Materials Reference Manual* for further detail about programs and services offered for seating.

The Customer's Own Material (COM) Program

offers the opportunity for customers to select fabrics that are not offered through the standard Steelcase surface materials program for use on Steelcase products. Through the COM program, Steelcase will test your materials for application on Steelcase products. Once approved, you can place your order. Steelcase will facilitate the entire ordering process and give you a production schedule. Steelcase will order the COM fabric directly from the textile manufacturer. For up-to-date information regarding fabric test results for all COM fabrics and details regarding yardage requirements for most Seating lines, visit the COM Web site. To locate the COM Web site:

- Visit www.steelcase.com
- Click on "Knowledge & Design"
- Select "Customer's Own Material"

Dimensions

▶ Page 130

Resources

Printed Materials

- ▶ Jersey Brochure (03-0000684)
- ▶ Seating Overview (03-0003368)

Computer Tools

- ▶ User Guide available on www.steelcase.com

Shipping

Jersey chairs are cartoned assembled only. Uncartoned shipments are not available.

Dimensions

Jersey Series

Features	Overall Depth	Width	Height	Functional Seat Depth	Seat Width	Seat Height from Floor	Back Width	Back Height from Seat
Jersey Series								
Work Chairs								
Pneumatic	25"	26 ¹ / ₄ "	35 ¹ / ₂ "-40"	17"*	20"	16"-20 ¹ / ₂ "	20"	18"
Multi-Use Chairs								
4-Leg with Arms	24"	24"	34"	17"	17 ¹ / ₂ "	17 ¹ / ₂ "	19"	15 ¹ / ₂ "
4-Leg Armless	24"	17 ¹ / ₂ "	34"	17"	17 ¹ / ₂ "	17 ¹ / ₂ "	19"	15 ¹ / ₂ "

*Models with seat depth measures 16³/₄"-20"

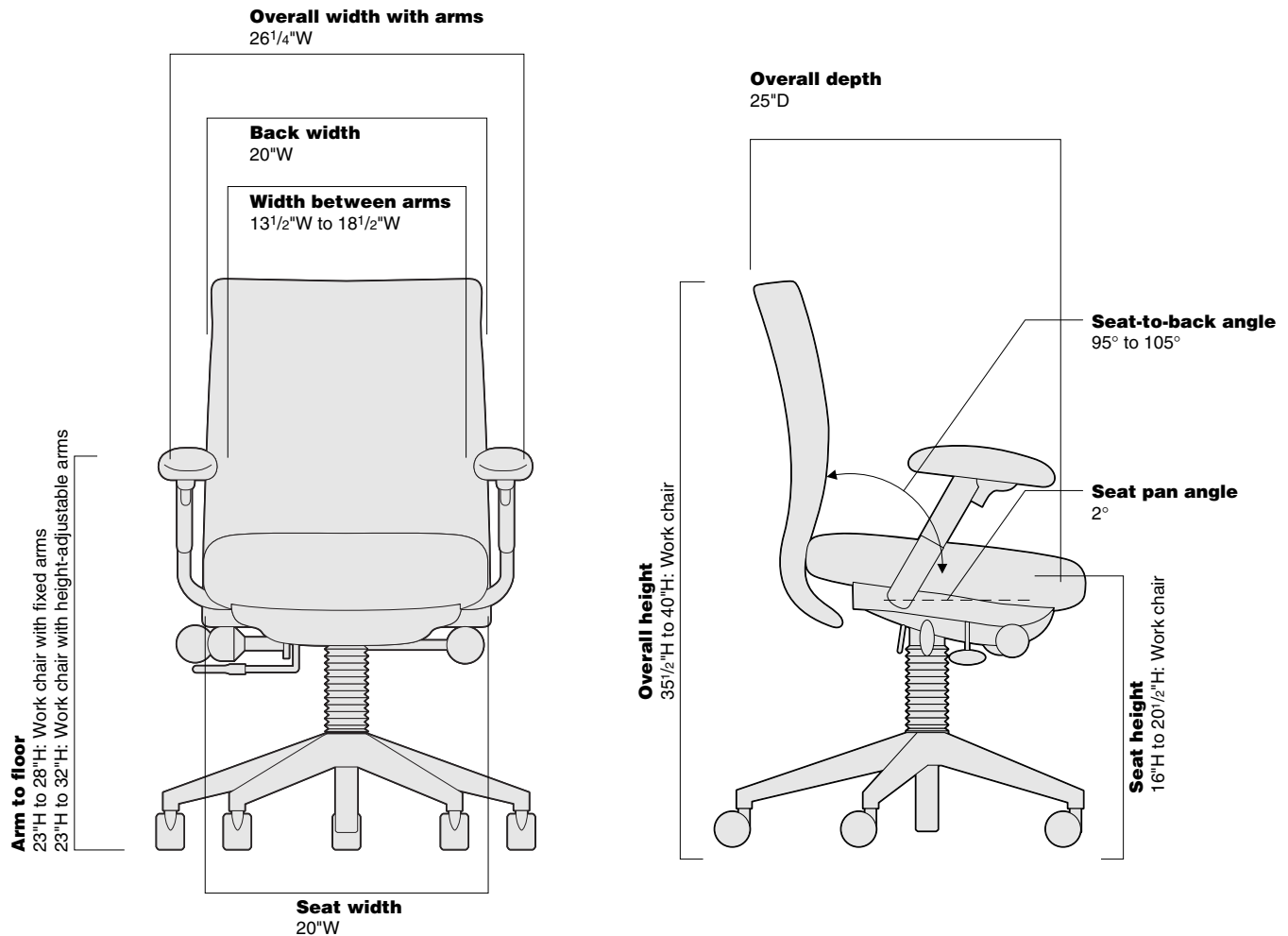

• Width • Between • Arms	• Arm to • Floor • Fixed • Arm	• Arm to • Floor • Height Adj • Arm	• Arm • Height • from Seat • Fixed Arm	• Arm • Height • from Seat • Adj-Height • Arm	• Seat • Pan • Angle	• Angle • Between • Seat and • Back
--------------------------------	---	--	---	---	----------------------------	--

Work Chairs

13½"-18½"	23"-28"	23"-32"	9"	7"-11"	2°	95°-105°
-----------	---------	---------	----	--------	----	----------

Multi-Use Chairs

21⅝"	25½"	N.A.	7½"	N.A.	2°	N.A.
N.A.	N.A.	N.A.	N.A.	N.A.	N.A.	N.A.

Jersey Series Work Chairs

Work Chair, Fabric



Tip: Arms, if specified, will match frame color (6205 Black standard, 4799 Platinum optional).

Standard Includes	Required to Specify
<ul style="list-style-type: none"> Need help? Product details, page 126 Synchro-tilt mechanism Pneumatic height adjustment Upright back lock Tilt tension Back: mesh Seat: fabric Five-arm base: reinforced black plastic Hard dual-wheel casters: black 	<ol style="list-style-type: none"> Style number Mesh color number for back: <ul style="list-style-type: none"> T084 Black T085 Grey T086 White T087 Yellow T088 Orange T089 Red T090 Green T091 Blue Fabric number for seat Options, if selected (see below)

Options	U.S. Price	Required to Specify
Surface Materials	<ul style="list-style-type: none"> 4799 Platinum frame with aluminum base 	+\$ 50 Specify with 4799 Platinum frame.
Fabric Seat	<ul style="list-style-type: none"> Jersey black fabric Buzz2 Customer's Own Material (COM) 	No cost No cost +\$ 30 Specify with 5011. Specify fabric color number. ▶ See <i>Surface Materials Reference Manual</i> to specify.
Jersey Pullover	<ul style="list-style-type: none"> Stretch pullover 	+\$ 69 Specify with jersey pullover and select color number: T092 Black T095 Yellow T096 Orange T097 Red T098 Green T099 Blue
Seating Mechanism	<ul style="list-style-type: none"> Deluxe synchro-tilt mechanism: provides seat depth and seat angle 	+\$ 70 Specify with deluxe synchro-tilt mechanism.
Fixed-Height Arms	<ul style="list-style-type: none"> Fixed-height, maintenance width-adjustable arms 	+\$ 70 Specify with fixed-height, maintenance width-adjustable arms.
Height-Adjustable Arms	<ul style="list-style-type: none"> Height- and maintenance width-adjustable arms 	+\$100 Specify with height- and maintenance width-adjustable arms.
Height-, Width-, and Pivot-Adjustable Arms	<ul style="list-style-type: none"> Height-, width-, and pivot-adjustable arms 	+\$115 Specify with height-, width-, and pivot-adjustable arms.
Casters	<ul style="list-style-type: none"> Soft dual-wheel casters for use on hard floors 	+\$ 25 Specify with soft casters.

Specification Information

Style Number	U.S. Base Price
TS38301	\$645

▶ Detailed dimensions, page 130



For Canadian Pricing
Multiply U.S. Price by 1.38.
▶ See page 1 for details.

Work Chair, Leather



Tip: Arms, if specified, will match frame color (6205 Black standard, 4799 Platinum optional).

Standard Includes	Required to Specify
<ul style="list-style-type: none"> Need help? Product details, page 126 Synchro-tilt mechanism Pneumatic height adjustment Upright back lock Tilt tension Back: mesh Seat: black leather Five-arm base: reinforced black plastic Hard dual-wheel casters: black 	<ul style="list-style-type: none"> 1 Style number 2 Mesh color number for back: <ul style="list-style-type: none"> T084 Black T085 Grey T086 White T087 Yellow T088 Orange T089 Red T090 Green T091 Blue 3 Options, if selected (see below)

Options	U.S. Price	Required to Specify
Surface Materials <ul style="list-style-type: none"> 4799 Platinum frame with aluminum base 	+\$ 50	Specify with 4799 Platinum frame.
Jersey Pullover <ul style="list-style-type: none"> Stretch pullover 	+\$ 69	Specify with jersey pullover and select color number: <ul style="list-style-type: none"> T092 Black T095 Yellow T096 Orange T097 Red T098 Green T099 Blue
Seating Mechanism <ul style="list-style-type: none"> Deluxe synchro-tilt mechanism: provides seat depth and seat angle 	+\$ 70	Specify with deluxe synchro-tilt mechanism.
Fixed-Height Arms <ul style="list-style-type: none"> Fixed-height, maintenance width-adjustable arms 	+\$ 70	Specify with fixed-height, maintenance width-adjustable arms.
Height-Adjustable Arms <ul style="list-style-type: none"> Height- and maintenance width-adjustable arms 	+\$100	Specify with height- and maintenance width-adjustable arms.
Height-, Width-, and Pivot-Adjustable Arms <ul style="list-style-type: none"> Height-, width-, and pivot-adjustable arms 	+\$115	Specify with height-, width-, and pivot-adjustable arms.
Casters <ul style="list-style-type: none"> Soft dual-wheel casters for use on hard floors 	+\$ 25	Specify with soft casters.

Specification Information

Style Number	U.S. Base Price
TS38302	\$725

► Detailed dimensions, page 130



For Canadian Pricing
Multiply U.S. Price by 1.38.
► See page 1 for details.

Jersey Series Multi-Use Chairs

Multi-Use Chair, Fabric, with Glides



Standard Includes		Required to Specify
<ul style="list-style-type: none"> ▶ Need help? Product details, page 126 	<ul style="list-style-type: none"> • Back: mesh • Seat: fabric • Arms, if selected: black • Steel four-leg frame: black • Glides: black plastic • Stacks four high 	<ol style="list-style-type: none"> 1 Style number 2 Mesh color number for back: <ul style="list-style-type: none"> T084 Black T085 Grey T086 White T087 Yellow T088 Orange T089 Red T090 Green T091 Blue 3 Fabric number for seat 4 Options, if selected (see below)

Options	U.S. Price	Required to Specify
Surface Materials <ul style="list-style-type: none"> • 4799 Platinum aluminum frame 	+\$50	Specify with 4799 Platinum frame.
Fabric Seat <ul style="list-style-type: none"> • Jersey black fabric • Buzz2 • Customer's Own Material (COM) 	No cost No cost +\$ 30	Specify with 5011. Specify fabric color number. ▶ See <i>Surface Materials Reference Manual</i> to specify.
Jersey Pullover <ul style="list-style-type: none"> • Stretch pullover 	+\$69	Specify with jersey pullover and select color number: <ul style="list-style-type: none"> T092 Black T095 Yellow T096 Orange T097 Red T098 Green T099 Blue

Specification Information

Style Number	U.S. Base Price
.....

With Arms

TS38304	\$398
.....



Without Arms

TS38305	\$368
.....



For Canadian Pricing
 Multiply U.S. Price by 1.38.
 ▶ See page 1 for details.

Multi-Use Chair, Leather, with Glides



	Standard Includes	Required to Specify
▶ Need help? Product details, page 126	<ul style="list-style-type: none"> • Back: mesh • Seat: black leather • Arms, if selected: black • Steel four-leg frame: black • Glides: black plastic • Stacks four high 	1 Style number 2 Mesh color number for back: T084 Black T085 Grey T086 White T087 Yellow T088 Orange T089 Red T090 Green T091 Blue 3 Options, if selected (see below)

	Options	U.S. Price	Required to Specify
Surface Materials	<ul style="list-style-type: none"> • 4799 Platinum aluminum frame 	+\$50	Specify with 4799 Platinum frame.
Jersey Pullover	<ul style="list-style-type: none"> • Stretch pullover 	+\$69	Specify with jersey pullover and select color number: T092 Black T095 Yellow T096 Orange T097 Red T098 Green T099 Blue

Specification Information

Style Number	U.S. Base Price
.....

With Arms

TS38306	\$478
.....



Without Arms

TS38307	\$448
.....



▶ Detailed dimensions,
page 130



For Canadian Pricing
Multiply U.S. Price by 1.38.
▶ See page 1 for details.

Multi-Use Chair, Fabric, with Casters

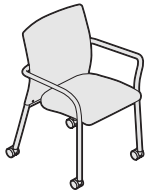

Standard Includes	Required to Specify
<p>► Need help? Product details, page 126</p> <ul style="list-style-type: none"> • Back: mesh • Seat: fabric • Arms, if selected: black • Steel four-leg frame: black • Hard dual-wheel casters: black • Stacks four high 	<ol style="list-style-type: none"> 1 Style number 2 Mesh color number for back: <ul style="list-style-type: none"> T084 Black T085 Grey T086 White T087 Yellow T088 Orange T089 Red T090 Green T091 Blue 3 Fabric number for seat 4 Options, if selected (see below)

Options	U.S. Price	Required to Specify
<p>Surface Materials</p> <ul style="list-style-type: none"> • 4799 Platinum aluminum frame 	+\$50	Specify with 4799 Platinum frame.
<p>Fabric Seat</p> <ul style="list-style-type: none"> • Jersey black fabric • Buzz2 • Customer's Own Material (COM) 	No cost No cost +\$ 30	Specify with 5011. Specify fabric color number. ► See <i>Surface Materials Reference Manual</i> to specify.
<p>Jersey Pullover</p> <ul style="list-style-type: none"> • Stretch pullover 	+\$69	Specify with jersey pullover and select color number: <ul style="list-style-type: none"> T092 Black T095 Yellow T096 Orange T097 Red T098 Green T099 Blue
<p>Casters</p> <ul style="list-style-type: none"> • Soft dual-wheel casters for use on hard floors 	+\$65	Specify with soft casters.

Specification Information	
• Style Number	• U.S. Base Price
•	•
•	•
•	•

With Arms

TS38308	\$438
•	•



Without Arms

TS38309	\$408
•	•



► Detailed dimensions, page 130

Multi-Use Chair, Leather, with Casters



	Standard Includes	Required to Specify
<p>► Need help? Product details, page 126</p>	<ul style="list-style-type: none"> • Back: mesh • Seat: black leather • Arms, if selected: black • Steel four-leg frame: black • Hard dual-wheel casters: black • Stacks four high 	<p>1 Style number</p> <p>2 Mesh color number for back:</p> <ul style="list-style-type: none"> T084 Black T085 Grey T086 White T087 Yellow T088 Orange T089 Red T090 Green T091 Blue <p>3 Options, if selected (see below)</p>

	Options	U.S. Price	Required to Specify
Surface Materials	<ul style="list-style-type: none"> • 4799 Platinum aluminum frame 	+\$50	Specify with 4799 Platinum frame.
Jersey Pullover	<ul style="list-style-type: none"> • Stretch pullover 	+\$69	Specify with jersey pullover and select color number: T092 Black T095 Yellow T096 Orange T097 Red T098 Green T099 Blue
Casters	<ul style="list-style-type: none"> • Soft dual-wheel casters for use on hard floors 	+\$65	Specify with soft casters.

Specification Information

Style Number	U.S. Base Price

With Arms

TS38310	\$518
----------------	-------



Without Arms

TS38311	\$488
----------------	-------



► Detailed dimensions,
page 130



For Canadian Pricing
Multiply U.S. Price by 1.38.
► See page 1 for details.

Jersey Pullover

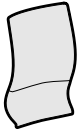

Standard Includes	Required to Specify
-------------------	---------------------

- Stretch pullover

- 1 Style number
- 2 Color number for stretch pullover:
 - T092 Black
 - T095 Yellow
 - T096 Orange
 - T097 Red
 - T098 Green
 - T099 Blue

Specification Information	
• Style Number	• U.S. Price
TS38303	\$69

• Style Number	• U.S. Price
TS38303	\$69



For Canadian Pricing
 Multiply U.S. Price by 1.38.
 ▶ See page 1 for details.

Understanding and Specifying Sensor 458 Series Work Chairs

Understanding Sensor 458 Series

Details	140
Dimension Variations	142
Dimensions	144

Specifying Sensor 458 Series

Work Chairs	146
Sled-Base Multi-Use Chairs	154
High Stools	156

Work Chairs

Highly adjustable task seating offers maximum personalization for people who sit most of the day performing repetitive tasks. By making a series of simple adjustments, you can customize the chair to your body, preferences, and tasks. These chairs provide continuous, stable, task-oriented comfort, and can be quickly adjusted to support you in upright, forward, and reclining work postures.

- Leap 462 Series
- Leap 464 Series WorkLounge
- Criterion 453 Series
- Think 465 Series
- Drive 461 Series
- Jersey Series
- Sensor 458 Series

Adjustability Features

► See page 11 for a comparison to other chairs.

Sensor 458 Series

Mechanisms

Synchro-tilt ●

Seat Adjustments

Pneumatic height ●

Back Adjustments

Lumbar height ●

Back tension ●

Variable back stop ●

Back height ●

Arm Adjustments

Arm height ●

Arm width ●

Other Features

Foot ring height on stool ●

Sensor 458 Series

Sensor's timeless styling and innovative self-adjusting design offer an exceptionally broad range of high-performance models to meet the needs of virtually everyone throughout an organization.

Outer back and outer seat are plastic. Fully upholstered outer back is an option.



Five-arm base is standard.

Arm caps are soft vinyl.

Seat height adjusts within a 5" range, from 16"H to 21"H.

Casters have hard, dual wheels that roll smoothly on carpets. Soft, dual-wheel casters are available for use on hard floors or chair mats.

Product Details



Work chairs are available in Size II mid- or high-back and Size II adjustable back.



Stools and sled-based multi-use chairs are available in mid-back styles.

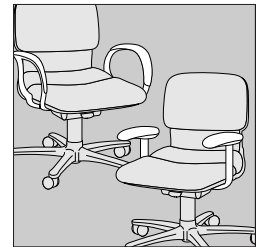

Arm styles include omega arms, adjustable-height and width arms, and armless models.

Adjustment Features

Seat Adjustments

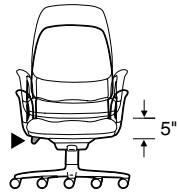

Seat height adjusts pneumatically. To lower, pull lever on right side while seated. To raise, pull lever and lift your weight off the chair.

Back Adjustments

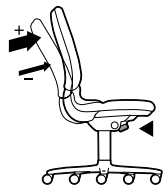

Back tension adjusts by turning knob. Turn knob clockwise to increase tension, counterclockwise to decrease.
Tip: Be sure to unlock (release) the variable back stop before adjusting the back tension.

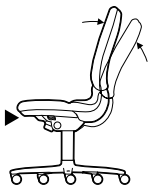

Variable back stop. Flick switch forward for full range of back angles. To limit back angle, recline to the desired position and flick switch back.
Tip: To lock in upright position, remove weight from back and flick switch back.

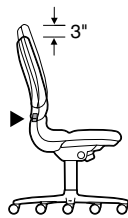

Back height adjusts up to 3" by holding button in while moving chair back up or down. Releasing button locks chair back in position.
Tip: Available only on Size II adjustable back models.

Arm Adjustments

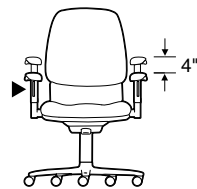

Arm height adjusts independently within a range of 4". Squeeze triggers in while moving arms up or down. Releasing triggers locks arms in position.
Tip: Available only on work chairs and stools.

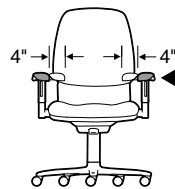

Arm width adjusts independently within a 4" range on chairs with this option. Grasp arm and move in or out. Arm will stay where positioned.

Other Features

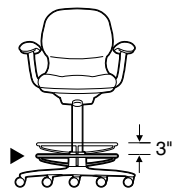

Foot ring height on stools adjusts by first lifting ring and rotating it counterclockwise to unlock it. Then raise or lower ring up to 3" to desired position before rotating it clockwise to lock it.

Surface Materials

► See surface materials on page 282 for specific availability or refer to the *Surface Materials Reference Manual* for further information.

Upholstery

- Fabric
- Fabric with soil-retardant treatment (option)
- Leather

Hard components

(base, arms, soft vinyl arm caps, outer back, frame, and casters)
• Monochromatic color from list of seating plastic color numbers will apply to all hard components.

Outer back

- Plastic color to match monochromatic color of other "hard components"
- Fully upholstered

Sled base

- Plastic color to match color of other "hard components"

Arms

- Plastic color to match color of other "hard components"

Arm caps

- Soft vinyl to match monochromatic color of other "hard components"

Glides

- Stainless steel on sled-base models

All Steelcase seating with standard upholstery fabrics complies with requirements of the BIFMA First Generation Voluntary Upholstered Furniture Flammability Standard, as well as the State of California Technical Bulletin 117. All standard seating is labeled to be in compliance with California TB117.

Programs & Services

► See the *Surface Materials Reference Manual* for further detail about programs and services offered for seating.

The Customer's Own Material (COM)

Program offers the opportunity for customers to select fabrics that are not offered through the standard Steelcase surface materials program for use on Steelcase products. Through the COM program, Steelcase will test your materials for application on Steelcase products. Once approved, you can place your order. Steelcase will facilitate the entire ordering process and give you a production schedule. Steelcase will order the COM fabric directly from the textile manufacturer. For up-to-date information regarding fabric test results for all COM fabrics and details regarding yardage requirements for most Seating lines, visit the COM Web site. To locate the COM Web site:

- Visit www.steelcase.com
- Click on "Knowledge & Design"
- Select "Customer's Own Material"

Soil retardants are treatments that provide long-term soil and stain resistance to a fabric without affecting the shade or the integrity of the fabric. The following Steelcase Textiles are available pre-treated with soil retardant. (You do not need to select the soil-retardant option for these fabrics and incur the \$17 upcharge.)

- Canzoné
- Cavalcade
- Jacks
- Link
- Regis
- Rook
- Skittles
- Roulette
- Spyder
- Sweepstakes

Soil-retardant treatment is available on all other seating fabrics at an additional \$17 U.S. per seating unit. To order this option, please select "Soil-Retardant Treatment" under "Optional Accessories."

For soil-retardant treatment on COMs, please select "Soil-Retardant Treatment" under "Optional Accessories." Minimums or additional yardage may be required. Please contact the vendor directly for specific information.

Extended lead times may be necessary for this service.

Contact your Steelcase Sales Service representative at 1.888.STEELCASE (1.888.783.3522).

Fire Codes

► See pages 289–290 for upholstery fabrics available for use with FCS modification. Sensor Size II adjustable-back models offer the Fire Code Seating option on the following upholstery fabrics only: Hampstead and Leather.

Steelcase offers Fire Code Seating modification (FCS) on nearly all seating models. The most rigorous fire codes in the nation have been developed in California, and the Steelcase FCS modification is designed to meet those codes. Fire Code Seating (FCS) indicates that a product is constructed to meet the strict fire code requirements of high public occupancy areas such as theaters, meeting rooms, and lobbies. The FCS standards will meet both the State of California Home Furnishing Technical Bulletin 133 (Cal TB 133) and Boston Fire Code (BFC). Boston adopted the California Home Furnishing Technical Bulletin TB 133 test standard in 1992.

Local codes may have special requirements for upholstery.

Dimensions

► Pages 142 and 144

Resources

Printed Materials

- Sensor Brochure (S11537)
- Seating Overview (03-0003368)

Computer Tools

- Electronic User Disk (S2338)—Windows

Dimension Variations

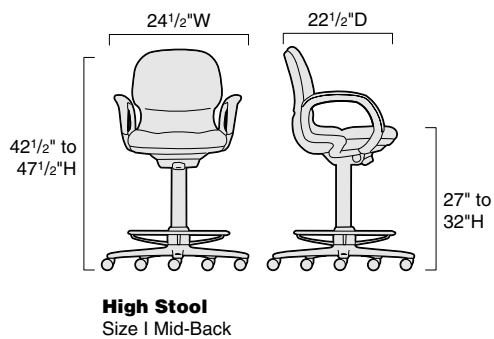
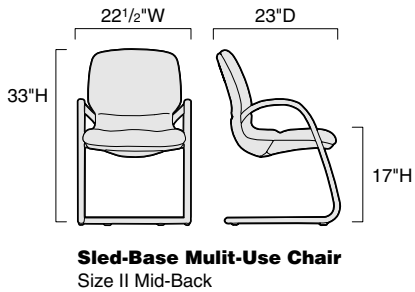
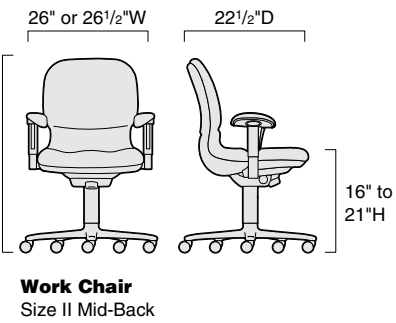
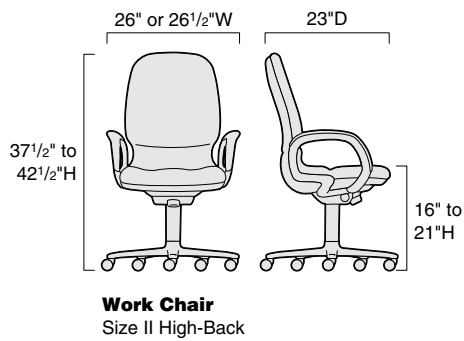
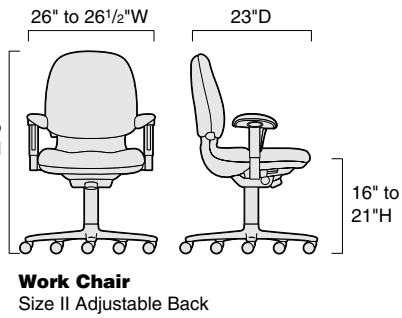
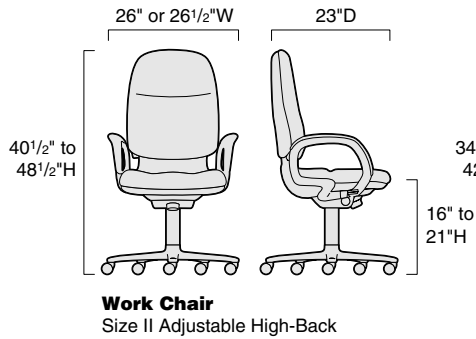

Dimensions

Sensor 458 Series

Type of Chair	Overall Depth	Width	Height	Seat Depth	Functional Seat Depth	Seat Width	Seat Height from Floor	Back Width	Back Height from Seat
---------------	---------------	-------	--------	------------	-----------------------	------------	------------------------	------------	-----------------------

Sensor 458 Series

Size II Adjustable High-Back Work Chairs

Omega Arms	23"	26"	40½"-48½"	18¼"	16¾"	20¼"	16"-21"	18"	24¼"-27¼"
Adjustable Arms	23"	26½"	40½"-48½"	18¼"	16¾"	20¼"	16"-21"	18"	24¼"-27¼"

Size II Adjustable-Back Work Chairs

Omega Arms	22"	26"	34½"-42½"	18¼"	16¾"	20¼"	16"-21"	18"	18¼"-21¼"
Adjustable Arms	22"	26½"	34½"-42½"	18¼"	16¾"	20¼"	16"-21"	18"	18¼"-21¼"

Size II High-Back Work Chairs

Omega Arms	23"	26"	37½"-42½"	17¾"	16½"	19¾"	16"-21"	18"	21½"
Adjustable Arms	23"	26½"	37½"-42½"	17¾"	16½"	19¾"	16"-21"	18"	21½"

Size II Mid-Back Work Chairs

Omega Arms	22½"	26"	33"-38"	17¾"	16½"	19¾"	16"-21"	18"	17"
Adjustable Arms	22½"	26½"	33"-38"	17¾"	16½"	19¾"	16"-21"	18"	17"

Size II Mid-Back Sled-Base Multi-Use Chairs

Loop Arms	23"	22½"	33"	17¾"	16½"	19¾"	17"	18"	17"
-----------	-----	------	-----	------	------	------	-----	-----	-----

Size I Mid-Back Stools

High Stool	22½"	24½"	42½"-47½"	16¾"	16"	19"	27"-32"	16½"	15½"
------------	------	------	-----------	------	-----	-----	---------	------	------

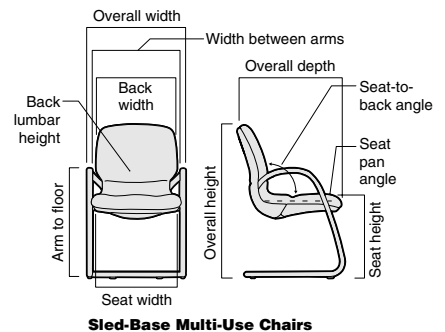
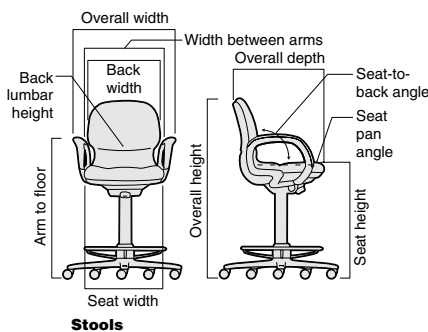
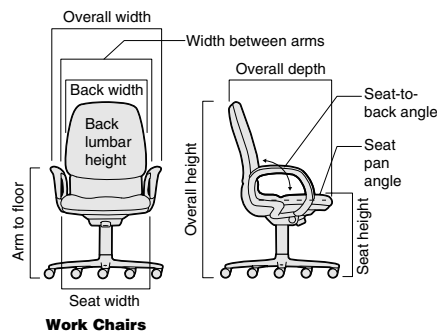

• Back Lumbar Height	• Width Between Arms	• Arm to Floor	• Arm Height from Seat	• Seat Pan Angle	• Angle Between Seat and Back	• Foot Ring Width	• Foot Ring Height
----------------------	----------------------	----------------	------------------------	------------------	-------------------------------	-------------------	--------------------

Size II Adjustable High-Back Work Chairs

7"-10"	20½"	24½"-29½"	8"	1°-4°	100°-110°	N.A.	N.A.
7"-10"	12¼"-20¼"	23¼"-32¼"	8¾"-12¾"	1°-4°	100°-110°	N.A.	N.A.

Size II Adjustable-Back Work Chairs

7"-10"	20½"	24½"-29½"	8"	1°-4°	100°-110°	N.A.	N.A.
7"-10"	12¼"-20¼"	23¼"-32¼"	8¾"-12¾"	1°-4°	100°-110°	N.A.	N.A.

Size II High-Back Work Chairs

8"	20¼"	24½"-29½"	8"	1°-4°	105°-120°	N.A.	N.A.
8"	12"-20"	23¼"-32¼"	8¾"-12¾"	1°-4°	105°-120°	N.A.	N.A.

Size II Mid-Back Work Chairs

8"	20¼"	24½"-29½"	8"	1°-4°	105°-120°	N.A.	N.A.
8"	12"-20"	23¼"-32¼"	8¾"-12¾"	1°-4°	105°-120°	N.A.	N.A.

Size II Mid-Back Sled-Base Multi-Use Chairs

8"	19"	23¾"	8"	1°-4°	105°	N.A.	N.A.
----	-----	------	----	-------	------	------	------

Size I Mid-Back Stools

8"	18¼"	34¾"-39¾"	8"	1°-4°	105°-120°	19¾"	9"-12"
----	------	-----------	----	-------	-----------	------	--------

Sensor 458 Series Size II Adjustable High-Back Work Chairs



Tip: Back height may be adjusted 3".

Tip: Always add suffixes in alphabetical order when specifying options to Sensor seating.

Tip: Fire Code Seating (FCS) option is available with certain upholstery fabric choices only.

► Pages 289–290

Standard Includes		Required to Specify
► Need help? Product details, page 140	<ul style="list-style-type: none"> • Synchro-tilt mechanism • Arms: plastic color to match base • Outer back and outer seat: plastic color • Back tension adjustment • Upholstery: fabric price group 1 • Five-arm base: plastic color • 2½"-diameter, hard composition, dual-wheel casters: plastic color to match base 	<ol style="list-style-type: none"> 1 Style number 2 Plastic color number for base, outer back, outer seat, arms, and casters 3 Fabric color number for upholstery 4 Options, if selected (see below) <p>► See <i>Surface Materials</i>, page 282.</p>

	Options	U.S. Price	Required to Specify
Surface Materials	Upholstery		
	• Fabric price group 1	No cost	Specify fabric color number.
	• Fabric price group 2	+\$ 20	Specify fabric color number.
	• Fabric price group 3	+\$ 40	Specify fabric color number.
	• Fabric price group 4	+\$ 55	Specify fabric color number.
	• Fabric price group 5	+\$ 70	Specify fabric color number.
	• Fabric price group 6	+\$ 100	Specify fabric color number.
	• Fabric price group 7	+\$ 140	Specify fabric color number.
	• Fabric price group 8	+\$ 185	Specify fabric color number.
	• Fabric price group 9	+\$ 220	Specify fabric color number.
	• Fabric price group 10	+\$ 255	Specify fabric color number.
	• Customer's Own Material (COM)	+\$ 30	► See <i>Surface Materials Reference Manual</i> to specify.
	• Steelcase leather upholstery	+\$ 815	Add suffix S to the style number and specify leather color number for upholstery.
• Customer's Own Leather (COL)	+\$ 549	Add suffix S to the style number.	
		► See <i>Surface Materials Reference Manual</i> to specify.	
	• Fire Code Seating (FCS)	+\$ 50	Add suffix F to the style number.
	• Soil-retardant treatment applied to upholstery fabric	+\$ 17	Specify <i>with soil-retardant treatment</i> .
	Fully upholstered		
	• Fabric fully upholstered outer back and outer seat	+\$ 130	Add suffix U to the style number.
	• Steelcase leather fully upholstered outer back and outer seat	+\$1215	Add suffix SU to the style number and specify leather color number.
	• Customer's Own Leather (COL) fully upholstered outer back and outer seat	+\$ 829	Add suffix SU to the style number.
			► See <i>Surface Materials Reference Manual</i> to specify.
Casters	• Soft, dual-wheel casters for use on hard floors	+\$ 18	Specify <i>with soft casters</i> .

► Detailed dimensions, page 144



For Canadian Pricing
Multiply U.S. Price by 1.38.
► See page 1 for details.

Sensor 458 Series Size II Adjustable-Back Work Chairs



Tip: Back height may be adjusted 3".

Tip: Leather upholstery is available on Size II adjustable-back models. Order through Specials.

Tip: Fire Code Seating (FCS) option is available with certain upholstery fabric choices only.
▶ Pages 289–290

Tip: Always add suffixes in alphabetical order when specifying options to Sensor seating.

Standard Includes		Required to Specify
▶ Need help? Product details, page 140	<ul style="list-style-type: none"> • Synchro-tilt mechanism • Back tension adjustment • Arms, if selected: plastic color to match base • Outer back and outer seat: plastic color • Upholstery: fabric price group 1 • Five-arm base: plastic color • 2½"-diameter, hard composition, dual-wheel casters: plastic color to match base 	<ol style="list-style-type: none"> 1 Style number 2 Plastic color number for base, outer back, outer seat, arms, and casters 3 Fabric color number for upholstery 4 Options, if selected (see below) <p>▶ See <i>Surface Materials</i>, page 282.</p>

Options	U.S. Price	Required to Specify
Surface Materials <ul style="list-style-type: none"> • Fabric price group 1 • Fabric price group 2 • Fabric price group 3 • Fabric price group 4 • Fabric price group 5 • Fabric price group 6 • Fabric price group 7 • Fabric price group 8 • Fabric price group 9 • Fabric price group 10 • Customer's Own Material (COM) • Fire Code Seating (FCS) • Soil-retardant treatment applied to upholstery fabric 	No cost +\$ 20 +\$ 40 +\$ 55 +\$ 70 +\$ 100 +\$ 140 +\$ 185 +\$ 220 +\$ 255 +\$ 30 +\$ 50 +\$ 17	Specify fabric color number. Specify fabric color number. Specify fabric color number. Specify fabric color number. Specify fabric color number. Specify fabric color number. Specify fabric color number. Specify fabric color number. Specify fabric color number. Specify fabric color number. Specify fabric color number. ▶ See <i>Surface Materials Reference Manual</i> to specify. Add suffix F to the style number. Specify <i>with soil-retardant treatment</i> .
Fully upholstered <ul style="list-style-type: none"> • Fabric fully upholstered outer back and outer seat 	+\$ 130	Add suffix U to the style number.
Casters <ul style="list-style-type: none"> • Soft, dual-wheel casters for use on hard floors 	+\$ 18	Specify <i>with soft casters</i> .

Specification Information

Height- and Width-Adjustable Arms



• Style Number
• U.S. Base Price

Omega Arms



• Style Number
• U.S. Base Price

With Arm Caps

Pneumatic

4581236W	\$1093	4581226	\$944
-----------------	--------	----------------	-------

Pneumatic with Variable Back Stop

4581436W	\$1148	4581426	\$999
-----------------	--------	----------------	-------

▶ Detailed dimensions, page 144



For Canadian Pricing
Multiply U.S. Price by 1.38.
▶ See page 1 for details.

► **Specification Information, continued**

Specification Information



• Style	• U.S.
• Number	• Base
	• Price

Without Arms

Pneumatic

4581206	\$828
----------------	-------

Pneumatic with Variable Back Stop

4581406	\$883
----------------	-------



For Canadian Pricing
Multiply U.S. Price by 1.38.
► See page 1 for details.

Sensor 458 Series Size II High-Back Work Chairs



	Standard Includes	Required to Specify
▶ Need help? Product details, page 140	<ul style="list-style-type: none"> • Synchro-tilt mechanism • Arms, if selected: plastic color to match base • Back tension adjustment • Outer back and outer seat: plastic color • Upholstery: fabric price group 1 • Five-arm base: plastic color • 2 1/8"-diameter, hard composition, dual-wheel casters: plastic color to match base 	<ol style="list-style-type: none"> 1 Style number 2 Plastic color number for base, outer back, outer seat, arms, and casters 3 Fabric color number for upholstery 4 Options, if selected (see below) <p>▶ See <i>Surface Materials</i>, page 282.</p>

	Options	U.S. Price	Required to Specify
Surface Materials	Upholstery		
	• Fabric price group 1	No cost	Specify fabric color number.
	• Fabric price group 2	+\$ 20	Specify fabric color number.
	• Fabric price group 3	+\$ 40	Specify fabric color number.
	• Fabric price group 4	+\$ 55	Specify fabric color number.
	• Fabric price group 5	+\$ 70	Specify fabric color number.
	• Fabric price group 6	+\$ 100	Specify fabric color number.
	• Fabric price group 7	+\$ 140	Specify fabric color number.
	• Fabric price group 8	+\$ 185	Specify fabric color number.
	• Fabric price group 9	+\$ 220	Specify fabric color number.
• Fabric price group 10	+\$ 255	Specify fabric color number.	
• Customer's Own Material (COM)	+\$ 30	▶ See <i>Surface Materials Reference Manual</i> to specify.	
• Steelcase leather upholstery	+\$ 815	Add suffix S to the style number and specify leather color number for upholstery.	
• Customer's Own Leather (COL)	+\$ 549	Add suffix S to the style number. ▶ See <i>Surface Materials Reference Manual</i> to specify.	
• Fire Code Seating (FCS)	+\$ 50	Add suffix F to the style number.	
• Soil-retardant treatment applied to upholstery fabric	+\$ 17	Specify <i>with soil-retardant treatment</i> .	
	Fully upholstered		
	• Fabric fully upholstered outer back and outer seat	+\$ 130	Add suffix U to the style number.
	• Steelcase leather fully upholstered outer back and outer seat	+\$1215	Add suffix SU to the style number and specify leather color number.
	• Customer's Own Leather (COL) fully upholstered outer back and outer seat	+\$ 829	Add suffix SU to the style number. ▶ See <i>Surface Materials Reference Manual</i> to specify.
Casters	• Soft, dual-wheel casters for use on hard floors	+\$ 18	Specify <i>with soft casters</i> .

Tip: Always add suffixes in alphabetical order when specifying options to Sensor seating.

Tip: Fire Code Seating (FCS) option is available with certain upholstery fabric choices only.
▶ Pages 289–290

▶ Detailed dimensions, page 144

 **For Canadian Pricing**
Multiply U.S. Price by 1.38.
▶ See page 1 for details.

Specification Information

Height- and Width-Adjustable Arms



• **Style Number**
• **U.S. Base Price**

Omega Arms



• **Style Number**
• **U.S. Base Price**

With Arm Caps

Pneumatic

4581234W	\$1033	4581224	\$884
-----------------	--------	----------------	-------

Pneumatic with Variable Back Stop

4581434W	\$1088	4581424	\$939
-----------------	--------	----------------	-------



• **Style Number**
• **U.S. Base Price**

Without Arms

Pneumatic

4581204	\$ 768
----------------	--------

Pneumatic with Variable Back Stop

4581404	\$ 823
----------------	--------



For Canadian Pricing
Multiply U.S. Price by 1.38.
▶ See page 1 for details.

Sensor 458 Series Size II Mid-Back Work Chairs



	Standard Includes	Required to Specify
<ul style="list-style-type: none"> ▶ Need help? Product details, page 140 	<ul style="list-style-type: none"> • Synchro-tilt mechanism • Arms, if selected: plastic color to match base • Outer back and outer seat: plastic color • Back tension adjustment • Upholstery: fabric price group 1 • Five-arm base: plastic color • 2 1/8"-diameter, hard composition, dual-wheel casters: plastic color to match base 	<ol style="list-style-type: none"> 1 Style number 2 Plastic color number for base, outer back, outer seat, arms, and casters 3 Fabric color number for upholstery 4 Options, if selected (see below) <ul style="list-style-type: none"> ▶ See <i>Surface Materials</i>, page 282.

	Options	U.S. Price	Required to Specify
Surface Materials	Upholstery		
	• Fabric price group 1	No cost	Specify fabric color number.
	• Fabric price group 2	+\$ 20	Specify fabric color number.
	• Fabric price group 3	+\$ 40	Specify fabric color number.
	• Fabric price group 4	+\$ 55	Specify fabric color number.
	• Fabric price group 5	+\$ 70	Specify fabric color number.
	• Fabric price group 6	+\$ 100	Specify fabric color number.
	• Fabric price group 7	+\$ 140	Specify fabric color number.
	• Fabric price group 8	+\$ 185	Specify fabric color number.
	• Fabric price group 9	+\$ 220	Specify fabric color number.
• Fabric price group 10	+\$ 255	Specify fabric color number.	
• Customer's Own Material (COM)	+\$ 30	▶ See <i>Surface Materials Reference Manual</i> to specify.	
• Steelcase leather upholstery	+\$ 815	Add suffix S to the style number and specify leather color number for upholstery.	
• Customer's Own Leather (COL)	+\$ 549	Add suffix S to the style number.	
	• Fire Code Seating (FCS)	+\$ 50	▶ See <i>Surface Materials Reference Manual</i> to specify.
	• Soil-retardant treatment applied to upholstery fabric	+\$ 17	Add suffix F to the style number. Specify <i>with soil-retardant treatment</i> .
	Fully upholstered		
	• Fabric fully upholstered outer back and outer seat	+\$ 130	Add suffix U to the style number.
	• Steelcase leather fully upholstered outer back and outer seat	+\$1215	Add suffix SU to the style number and specify leather color number.
	• Customer's Own Leather (COL) fully upholstered outer back and outer seat	+\$ 829	Add suffix SU to the style number.
			▶ See <i>Surface Materials Reference Manual</i> to specify.
Casters	• Soft, dual-wheel casters for use on hard floors	+\$ 18	Specify <i>with soft casters</i> .

Tip: Always add suffixes in alphabetical order when specifying options to Sensor seating.

Tip: Fire Code Seating (FCS) option is available with certain upholstery fabric choices only.
▶ Pages 289–290

▶ Detailed dimensions, page 144

 **For Canadian Pricing**
Multiply U.S. Price by 1.38.
▶ See page 1 for details.

Specification Information

Height- and Width-Adjustable Arms



• **Style Number**
• **U.S. Base Price**

Omega Arms



• **Style Number**
• **U.S. Base Price**

With Arm Caps

Pneumatic

4581233W	\$ 988	4581223	\$839
-----------------	--------	----------------	-------

Pneumatic with Variable Back Stop

4581433W	\$1043	4581423	\$894
-----------------	--------	----------------	-------



• **Style Number**
• **U.S. Base Price**

Without Arms

Pneumatic

4581203	\$ 723
----------------	--------

Pneumatic with Variable Back Stop

4581403	\$ 778
----------------	--------



For Canadian Pricing
Multiply U.S. Price by 1.38.
▶ See page 1 for details.



For Canadian Pricing
Multiply U.S. Price by 1.38.
▶ See page 1 for details.

Sensor 458 Series Size I Mid-Back High Stools



Tip: Leather upholstery is available on Size I mid-back models. Order through Specials.

Tip: Fire Code Seating (FCS) option is available with certain upholstery fabric choices only.
▶ Pages 289–290

Tip: Always add suffixes in alphabetical order when specifying options to Sensor seating.

Standard Includes		Required to Specify	
▶ Need help? Product details, page 140	<ul style="list-style-type: none"> • Synchro-tilt mechanism • Arms, if selected: plastic color to match base • Back tension adjustment • Outer back and outer seat: plastic color • Upholstery: fabric price group 1 • Five-arm base: plastic color • Foot ring: plastic color • 2½"-diameter, hard composition, dual-wheel casters: plastic color to match base 	<ol style="list-style-type: none"> 1 Style number 2 Plastic color number for base, outer back, outer seat, arms, and casters 3 Fabric color number for upholstery 4 Options, if selected (see below) 	▶ See <i>Surface Materials</i> , page 282.
Options		U.S. Price	Required to Specify
Surface Materials	Upholstery		
	<ul style="list-style-type: none"> • Fabric price group 1 • Fabric price group 2 • Fabric price group 3 • Fabric price group 4 • Fabric price group 5 • Fabric price group 6 • Fabric price group 7 • Fabric price group 8 • Fabric price group 9 • Fabric price group 10 • Customer's Own Material (COM) • Fire Code Seating (FCS) • Soil-retardant treatment applied to upholstery fabric 	<ul style="list-style-type: none"> No cost +\$ 20 +\$ 40 +\$ 55 +\$ 70 +\$ 100 +\$ 140 +\$ 185 +\$ 220 +\$ 255 +\$ 30 +\$ 50 +\$ 17 	<ul style="list-style-type: none"> Specify fabric color number. Specify fabric color number. Specify fabric color number. Specify fabric color number. Specify fabric color number. Specify fabric color number. Specify fabric color number. Specify fabric color number. Specify fabric color number. Specify fabric color number. ▶ See <i>Surface Materials Reference Manual</i> to specify. Add suffix F to the style number. Specify <i>with soil-retardant treatment</i>.
	Fully upholstered		
	<ul style="list-style-type: none"> • Fabric fully upholstered outer back and outer seat 	+\$ 130	Add suffix U to the style number.
Casters	<ul style="list-style-type: none"> • Soft, dual-wheel casters for use on hard floors 	+\$ 18	Specify <i>with soft casters</i> .

▶ Detailed dimensions, page 144



For Canadian Pricing
Multiply U.S. Price by 1.38.
▶ See page 1 for details.

Specification Information

Height- and Width-Adjustable Arms



• **Style Number**
• **U.S. Base Price**

Omega Arms



• **Style Number**
• **U.S. Base Price**

With Arm Caps

Pneumatic

4588231W	\$1292	4588221	\$1143
-----------------	--------	----------------	--------

Pneumatic with Variable Back Stop

4588431W	\$1347	4588421	\$1198
-----------------	--------	----------------	--------



• **Style Number**
• **U.S. Base Price**

Without Arms

Pneumatic

4588201	\$1027
----------------	--------

Pneumatic with Variable Back Stop

4588401	\$1082
----------------	--------

Sensor 458 Series



For Canadian Pricing
Multiply U.S. Price by 1.38.
▶ See page 1 for details.



Understanding and Specifying Rally 457 Series Work Chairs

Understanding Rally 457 Series

Details	160
Dimensions	162

Specifying Rally 457 Series

Work Chairs	164
Mid-Back Multi-Use Chairs	166

Work Chairs

Adjustable work chairs offer basic ergonomic comfort for people who have varied tasks and tend to be in and out of the office during the day. Features include adjustable seat height, back tension, and upright back lock. Also featured is the no front-rise seat—in other words, when you lean back, the front edge of the seat doesn't rise up, lifting your legs off the floor and cutting off circulation.

- Rally 457 Series
- Protégé 433 Series
- Cachet 487 Series

Rally 457 Series

Rally is contemporary in design with soft, pleasing contours. Rally features basic adjustments at an attractive price.

Outer back and outer seat are plastic. Fully upholstered outer back and outer seat is available.



Arms are available to match the outer back and base.

Seat height adjusts within a 5" range from 16"H to 21"H on work chairs with a pneumatic adjustment mechanism.

Five-arm base is standard.

Hard, dual-wheel casters are provided for use on carpets. Soft, dual-wheel casters are available for use on hard floors or chair mats.

Product Details



High-back and mid-back work chairs are available.



Multi-use chair bases are available in two styles: fixed-height swivel and sled.

Adjustability Features

	Rally	Protegé	Cachet
Mechanisms			
Advanced swivel-tilt	●	●	
Balanced Action Rocker (BAR)			●
Seat Adjustments			
Pneumatic height	●	●	●
Back Adjustments			
Upright back lock	●	●	
Back tension	●	●	
Self adjusting			●

Adjustment Features

Seat Adjustments

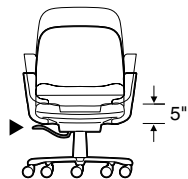

Seat height adjusts pneumatically. To lower, hold handle up while seated. To raise, hold handle up and lift your weight off the chair.
Tip: Multi-use chairs are fixed height only and do not include back tension adjustment.

Back Adjustments

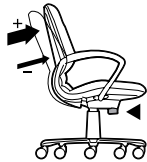

Back tension adjusts by turning knob. Turn knob clockwise to increase tension, counterclockwise to decrease.



Upright back lock. Pull knob out to release back; push knob in to lock back.



Surface Materials

► See surface materials on page 282 for specific availability or refer to the *Surface Materials Reference Manual* for further information.

Upholstery

- Fabric
- Fabric with soil-retardant treatment (option)
- Leather

Hard components

(base, arms, plastic arm caps, outer back, outer seat, frame, and casters)

- Monochromatic color from list of seating plastic color numbers will apply to all hard components.

Outer back and outer seat

- Plastic color to match monochromatic color of other "hard components"
- Fully upholstered

Sled base

- Plastic color to match color of other "hard components"

Arms

- Plastic color to match color of other "hard components"

Glides

- Plastic on sled-base chair

All Steelcase seating with standard upholstery fabrics complies with requirements of the BIFMA First Generation Voluntary Upholstered Furniture Flammability Standard, as well as the State of California Technical Bulletin 117. All standard seating is labeled to be in compliance with California TB117.

Programs & Services

► See the *Surface Materials Reference Manual* for further detail about programs and services offered for seating.

The Customer's Own Material (COM) Program

offers the opportunity for customers to select fabrics that are not offered through the standard Steelcase surface materials program for use on Steelcase products. Through the COM program, Steelcase will test your materials for application on Steelcase products. Once approved, you can place your order. Steelcase will facilitate the entire ordering process and give you a production schedule. Steelcase will order the COM fabric directly from the textile manufacturer. For up-to-date information regarding fabric test results for all COM fabrics and details regarding yardage requirements for most Seating lines, visit the COM Web site. To locate the COM Web site:

- Visit www.steelcase.com
- Click on "Knowledge & Design"
- Select "Customer's Own Material"

Soil retardants are treatments that provide long-term soil and stain resistance to a fabric without affecting the shade or the integrity of the fabric. The following Steelcase Textiles are available pre-treated with soil retardant. (You do not need to select the soil-retardant option for these fabrics and incur the \$17 upcharge.)

- Canzoné
- Cavalcade
- Jacks
- Link
- Regis
- Rook
- Roulette
- Skittles
- Spyder
- Sweepstakes

Soil-retardant treatment is available on all other seating fabrics at an additional \$17 U.S. per seating unit. To order this option, please select "Soil-Retardant Treatment" under "Optional Accessories."

For soil-retardant treatment on COMs, please select "Soil-Retardant Treatment" under "Optional Accessories." Minimums or additional yardage may be required. Please contact the vendor directly for specific information.

Extended lead times may be necessary for this service.

Contact your Steelcase Sales Service representative at 1.888.STEELCASE (1.888.783.3522).

Fire Codes

► See pages 289–290 for upholstery fabrics available for use with FCS modification.

Steelcase offers Fire Code Seating modification (FCS) on nearly all seating models. The most rigorous fire codes in the nation have been developed in California, and the Steelcase FCS modification is designed to meet those codes. Fire Code Seating (FCS) indicates that a product is constructed to meet the strict fire code requirements of high public occupancy areas such as theaters, meeting rooms, and lobbies. The FCS standards will meet both the State of California Home Furnishing Technical Bulletin 133 (Cal TB 133) and Boston Fire Code (BFC). Boston adopted the California Home Furnishing Technical Bulletin TB 133 test standard in 1992.

Local codes may have special requirements for upholstery.

Dimensions

► Page 162

Resources

Printed Materials

- Rally Brochure (S11004)
- Seating Overview (03-0003368)

Dimensions

Rally 457 Series

Features	Overall Depth	Width	Height	Seat Depth	Functional Seat Depth	Seat Width	Seat Height from Floor	Back Width	Back Height from Seat
Rally 457 Series									
High-Back Work Chairs									
Pneumatic	22 ⁵ / ₈ "	26 ¹ / ₂ "	34"–39"	17 ⁷ / ₈ "	15 ¹ / ₂ "	20"	16"–21"	20"	20 ³ / ₄ "
Mid-Back Work Chairs									
Pneumatic	22 ³ / ₈ "	26 ¹ / ₂ "	33"–38"	17 ⁷ / ₈ "	15 ¹ / ₂ "	20"	16"–21"	20"	19 ¹ / ₄ "
Mid-Back Multi-Use Chairs									
Swivel/Fixed Base	22 ¹ / ₄ "	26 ¹ / ₂ "	34"	17 ⁷ / ₈ "	15 ¹ / ₂ "	20"	18"	20"	19 ¹ / ₄ "
Sled Base	22 ¹ / ₂ "	23"	33 ³ / ₄ "	17 ⁷ / ₈ "	15 ¹ / ₂ "	20"	18"	20"	19 ¹ / ₄ "

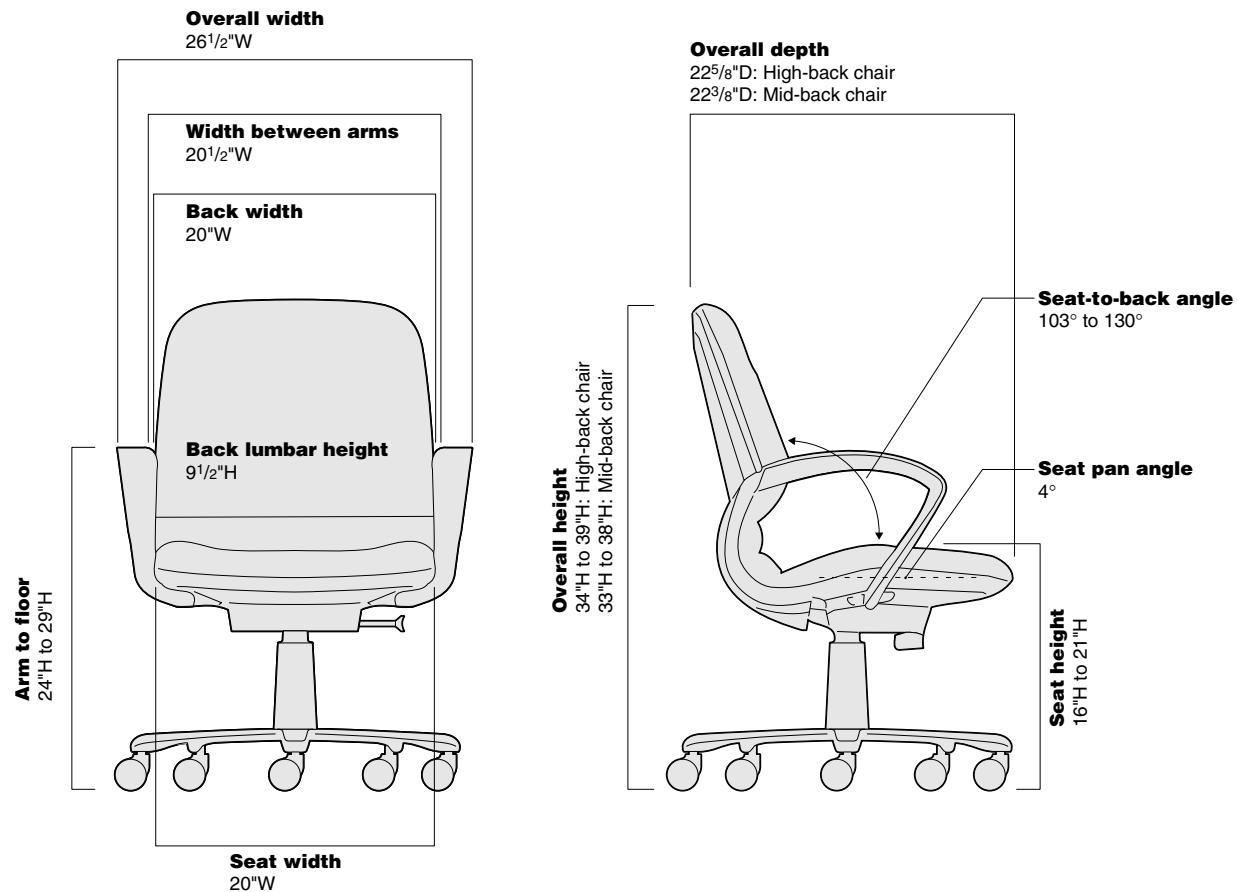

• Back Lumbar Height	• Width Between Arms	• Arm to Floor	• Arm Height from Seat	• Seat Pan Angle	• Angle Between Seat and Back
----------------------	----------------------	----------------	------------------------	------------------	-------------------------------

High-Back Work Chairs

9½"	20½"	24"-29"	8"	4°	103°-130°
-----	------	---------	----	----	-----------

Mid-Back Work Chairs

9½"	20½"	24"-29"	8"	4°	103°-130°
-----	------	---------	----	----	-----------

Mid-Back Multi-Use Chairs

9½"	20½"	26"	8"	4°	105°
9½"	19½"	23¾"	7½"	4°	105°

Rally 457 Series Work Chairs



Standard Includes		Required to Specify
<ul style="list-style-type: none"> ▶ Need help? Product details, page 160 	<ul style="list-style-type: none"> • Advanced swivel-tilt mechanism • Arms, if selected: plastic color to match base • Outer back and outer seat: plastic • Back tension adjustment • Upholstery: fabric price group 1 • Five-arm base: plastic color • 2 1/8"-diameter, hard composition, dual-wheel casters: plastic color to match base 	<ol style="list-style-type: none"> 1 Style number 2 Plastic color number for base, outer back, outer seat, arms, and casters 3 Fabric color number for upholstery 4 Options, if selected (see below) <ul style="list-style-type: none"> ▶ See <i>Surface Materials</i>, page 282.

	Options	U.S. Price	Required to Specify
Surface Materials	Upholstery		
	• Fabric price group 1	No cost	Specify fabric color number.
	• Fabric price group 2	+\$ 20	Specify fabric color number.
	• Fabric price group 3	+\$ 40	Specify fabric color number.
	• Fabric price group 4	+\$ 55	Specify fabric color number.
	• Fabric price group 5	+\$ 70	Specify fabric color number.
	• Fabric price group 6	+\$100	Specify fabric color number.
	• Fabric price group 7	+\$140	Specify fabric color number.
	• Fabric price group 8	+\$185	Specify fabric color number.
	• Fabric price group 9	+\$220	Specify fabric color number.
• Fabric price group 10	+\$255	Specify fabric color number.	
• Customer's Own Material (COM)	+\$ 30	▶ See <i>Surface Materials Reference Manual</i> to specify.	
• Steelcase leather upholstery	+\$551	Add suffix S to style number and specify leather color number.	
• Customer's Own Leather (COL)	+\$320	Add suffix S to style number.	
		▶ See <i>Surface Materials Reference Manual</i> to specify.	
	• Fire Code Seating (FCS)	+\$ 50	Add suffix F to the style number.
	• Soil-retardant treatment applied to upholstery fabric	+\$ 17	Specify <i>with soil-retardant treatment</i> .
	Fully upholstered		
	• Fabric fully upholstered outer back and outer seat	+\$146	Add suffix U to the style number.
	• Steelcase leather fully upholstered outer back and outer seat	+\$956	Add suffix SU to the style number and specify leather color number.
	• Customer's Own Leather (COL) fully upholstered outer back and outer seat	+\$496	Add suffix SU to the style number.
			▶ See <i>Surface Materials Reference Manual</i> to specify.
Casters	• Soft, dual-wheel casters for use on hard floors (2 1/8")	+\$ 18	Specify <i>with soft casters</i> .

Tip: Always add suffixes in alphabetical order when specifying options to Rally seating.

Tip: Fire Code Seating (FCS) option is available with certain upholstery fabric choices only.

▶ Pages 289–290

▶ Detailed dimensions, page 162



For Canadian Pricing
Multiply U.S. Price by 1.38.
▶ See page 1 for details.

Specification Information

With Arms



• **Style Number**
• **U.S. Base Price**

Without Arms



• **Style Number**
• **U.S. Base Price**

High-Back Work Chairs

Pneumatic

4571224	\$704	4571204	\$646
----------------	-------	----------------	-------

Pneumatic with Upright Back Lock

4571424	\$744	4571404	\$686
----------------	-------	----------------	-------

With Arms



• **Style Number**
• **U.S. Base Price**

Without Arms



• **Style Number**
• **U.S. Base Price**

Mid-Back Work Chairs

Pneumatic

4571223	\$657	4571203	\$599
----------------	-------	----------------	-------

Pneumatic with Upright Back Lock

4571423	\$697	4571403	\$639
----------------	-------	----------------	-------

Rally 457 Series



For Canadian Pricing
Multiply U.S. Price by 1.38.
▶ See page 1 for details.

Rally 457 Series Mid-Back Multi-Use Chairs



	Standard Includes	Required to Specify
<ul style="list-style-type: none"> ▶ Need help? Product details, page 160 	<ul style="list-style-type: none"> • Arms, if selected: plastic color to match base • Fixed height with swivel-only base • Frame and arms on sled-base models: plastic color • Outer back and outer seat: plastic • Upholstery: fabric price group 1 • Five-arm base: plastic color • Glides on sled base: plastic • 2½"-diameter, hard composition, dual-wheel casters: plastic color to match base 	<ol style="list-style-type: none"> 1 Style number 2 Plastic color number for base, outer back, outer seat, arms, and casters 3 Fabric color number for upholstery 4 Options, if selected (see below) <ul style="list-style-type: none"> ▶ See <i>Surface Materials</i>, page 282.

	Options	U.S. Price	Required to Specify
Surface Materials	Upholstery		
	• Fabric price group 1	No cost	Specify fabric color number.
	• Fabric price group 2	+\$ 20	Specify fabric color number.
	• Fabric price group 3	+\$ 40	Specify fabric color number.
	• Fabric price group 4	+\$ 55	Specify fabric color number.
	• Fabric price group 5	+\$ 70	Specify fabric color number.
	• Fabric price group 6	+\$100	Specify fabric color number.
	• Fabric price group 7	+\$140	Specify fabric color number.
	• Fabric price group 8	+\$185	Specify fabric color number.
	• Fabric price group 9	+\$220	Specify fabric color number.
• Fabric price group 10	+\$255	Specify fabric color number.	
• Customer's Own Material (COM)	+\$ 30	▶ See <i>Surface Materials Reference Manual</i> to specify.	
• Steelcase leather upholstery	+\$551	Add suffix S to style number and specify leather color number.	
• Customer's Own Leather (COL)	+\$320	Add suffix S to style number.	
		▶ See <i>Surface Materials Reference Manual</i> to specify.	
	• Fire Code Seating (FCS)	+\$ 50	Add suffix F to the style number.
	• Soil-retardant treatment applied to upholstery fabric	+\$ 17	Specify <i>with soil-retardant treatment</i> .
	Fully upholstered		
	• Fabric fully upholstered outer back and outer seat	+\$146	Add suffix U to the style number.
	• Steelcase leather fully upholstered outer back and outer seat	+\$956	Add suffix SU to the style number and specify leather color number.
	• Customer's Own Leather (COL) fully upholstered outer back and outer seat	+\$496	Add suffix SU to the style number.
			▶ See <i>Surface Materials Reference Manual</i> to specify.
Casters	• Soft, dual-wheel casters for use on hard floors on side chairs with five-arm base (2½")	+\$ 18	Specify <i>with soft casters</i> .

Tip: Always add suffixes in alphabetical order when specifying options to Rally seating.

Tip: Fire Code Seating (FCS) option is available with certain upholstery fabric choices only.

▶ Pages 289–290

▶ Detailed dimensions, page 162



For Canadian Pricing
Multiply U.S. Price by 1.38.

▶ See page 1 for details.

Specification Information

With Arms



• Style	• U.S.
• Number	• Base
•	• Price
•	•

Without Arms



• Style	• U.S.
• Number	• Base
•	• Price
•	•

Mid-Back Multi-Use Chairs

Fixed-Height Swivel Base

4573023	\$595	4573003	\$537
•	•	•	•

Sled-Base with Arms



• Style	• U.S.
• Number	• Base
•	• Price
•	•

Mid-Back Multi-Use Chairs

Sled-Base

4575023	\$488
•	•



For Canadian Pricing
Multiply U.S. Price by 1.38.
▶ See page 1 for details.



Understanding and Specifying Protegé 433 Series Work Chairs

Understanding Protegé 433 Series

Details	170
Dimensions	172

Specifying Protegé 433 Series

Work Chairs	174
Multi-Use Chairs	176
Sled-Base Multi-Use Chairs	178

Work Chairs

Adjustable work chairs offer basic ergonomic comfort for people who have varied tasks and tend to be in and out of the office during the day. Features include adjustable seat height, back tension, and upright back lock. Also featured is the no front-rise seat—in other words, when you lean back, the front edge of the seat doesn't rise up, lifting your legs off the floor and cutting off circulation.

- Rally 457 Series
- Protegé 433 Series
- Cachet 487 Series

Protegé 433 Series

Protegé is an economic, general-use solution with basic ergonomic features. Protegé is stylish, comfortable, and well suited for a wide range of tasks, including moderate computer use.

Outer back is plastic. Fully upholstered outer back is an option.



Five-arm base is standard.

Arms are available without arm caps or with soft vinyl arm caps.

Seat height adjusts with a 5" range from 16"H to 21"H with a pneumatic adjustment mechanism.

Hard, dual-wheel casters are provided for use on carpets. Soft, dual-wheel casters are available for use on hard floors or chair mats.

Product Details



Work and multi-use chairs are available with or without arms.



Multi-use chair bases are available in two styles: advanced swivel-tilt and sled base.

Adjustability Features

	Rally	Protegé	Cachet
Mechanisms			
Advanced swivel-tilt	•	●	
Balanced Action Rocker (BAR)			•
Seat Adjustments			
Pneumatic height	•	●	•
Back Adjustments			
Upright back lock	•	●	
Back tension	•	●	
Self adjusting			•

Adjustment Features

Seat Adjustments

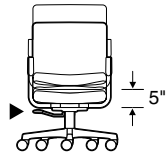

Seat height adjusts pneumatically. To lower, hold handle up while seated. To raise, hold handle up and keep your weight off the chair.

Back Adjustments



Back tension adjusts by turning knob. Turn knob clockwise to increase tension, counterclockwise to decrease.



Upright back lock. Flick switch forward to lock; flick switch back to tilt.

Surface Materials

▶ See surface materials on page 282 for specific availability or refer to the *Surface Materials Reference Manual* for further information.

Upholstery

- Fabric
- Fabric with soil-retardant treatment (option)
- Leather

Hard components

(base, arms, plastic arm caps, outer back, outer seat, frame, and casters)

- Monochromatic color from list of seating plastic color numbers will apply to all hard components.

Base

- Plastic color to match monochromatic color of other “hard components”

Outer back

- Plastic color to match monochromatic color of other “hard components”
- Fully upholstered

Arms and arm caps

- Plastic color to match monochromatic color of other “hard components”

Glides

- Plastic on sled base models

All Steelcase seating with standard upholstery fabrics

complies with requirements of the BIFMA First Generation Voluntary Upholstered Furniture Flammability Standard, as well as the State of California Technical Bulletin 117. All standard seating is labeled to be in compliance with California TB117.

Programs & Services

▶ See the *Surface Materials Reference Manual* for further detail about programs and services offered for seating.

The Customer’s Own Material (COM) Program

offers the opportunity for customers to select fabrics that are not offered through the standard Steelcase surface materials program for use on Steelcase products. Through the COM program, Steelcase will test your materials for application on Steelcase products. Once approved, you can place your order. Steelcase will facilitate the entire ordering process and give you a production schedule. Steelcase will order the COM fabric directly from the textile manufacturer. For up-to-date information regarding fabric test results for all COM fabrics and details regarding yardage requirements for most Seating lines, visit the COM Web site. To locate the COM Web site:

- Visit www.steelcase.com
- Click on “Knowledge & Design”
- Select “Customer’s Own Material”

Soil retardants are treatments that provide long-term soil and stain resistance to a fabric without affecting the shade or the integrity of the fabric. The following Steelcase Textiles are available pre-treated with soil retardant. (You do not need to select the soil-retardant option for these fabrics and incur the \$17 upcharge.)

- Canzoné
- Cavalcade
- Jacks
- Link
- Regis
- Rook
- Roulette
- Skittles
- Spyder
- Sweepstakes

Soil-retardant treatment is available on all other seating fabrics at an additional \$17 U.S. per seating unit. To order this option, please select “Soil-Retardant Treatment” under “Optional Accessories.”

For soil-retardant treatment on COMs, please select “Soil-Retardant Treatment” under “Optional Accessories.” Minimums or additional yardage may be required. Please contact the vendor directly for specific information.

Extended lead times may be necessary for this service.

Contact your Steelcase Sales Service representative at 1.888.STEELCASE (1.888.783.3522).

Fire Codes

▶ See pages 289–290 for upholstery fabrics available for use with FCS modification.

Steelcase offers Fire Code

Seating modification (FCS) on nearly all seating models. The most rigorous fire codes in the nation have been developed in California, and the Steelcase FCS modification is designed to meet those codes. Fire Code Seating (FCS) indicates that a product is constructed to meet the strict fire code requirements of high public occupancy areas such as theaters, meeting rooms, and lobbies. The FCS standards will meet both the State of California Home Furnishing Technical Bulletin 133 (Cal TB 133) and Boston Fire Code (BFC). Boston adopted the California Home Furnishing Technical Bulletin TB 133 test standard in 1992.

Local codes may have special requirements for upholstery.

Dimensions

▶ Page 172

Resources

Printed Materials

- ▶ Protégé Brochure (S11005)
- ▶ Seating Overview (03-0003368)

Dimensions

Protegé 433 Series

Features	Overall Depth	Width	Height	Seat Depth	Functional Seat Depth	Seat Width	Seat Height from Floor	Back Width	Back Height from Seat
----------	---------------	-------	--------	------------	-----------------------	------------	------------------------	------------	-----------------------

Protegé 433 Series

Work Chairs

Pneumatic	21 1/4"	23"	33 3/4"–38 3/4"	17 1/2"	16"	19 1/2"	16"–21"	19"	19 1/4"
-----------	---------	-----	-----------------	---------	-----	---------	---------	-----	---------

Multi-Use Chairs

Fixed Height	21 1/4"	23"	35 1/4"	17 1/2"	16"	19 1/2"	17 1/4"	19"	19 1/4"
Sled Base	21 1/4"	23"	35"	17 1/2"	16"	19 1/2"	18 1/4"	19"	19 1/4"

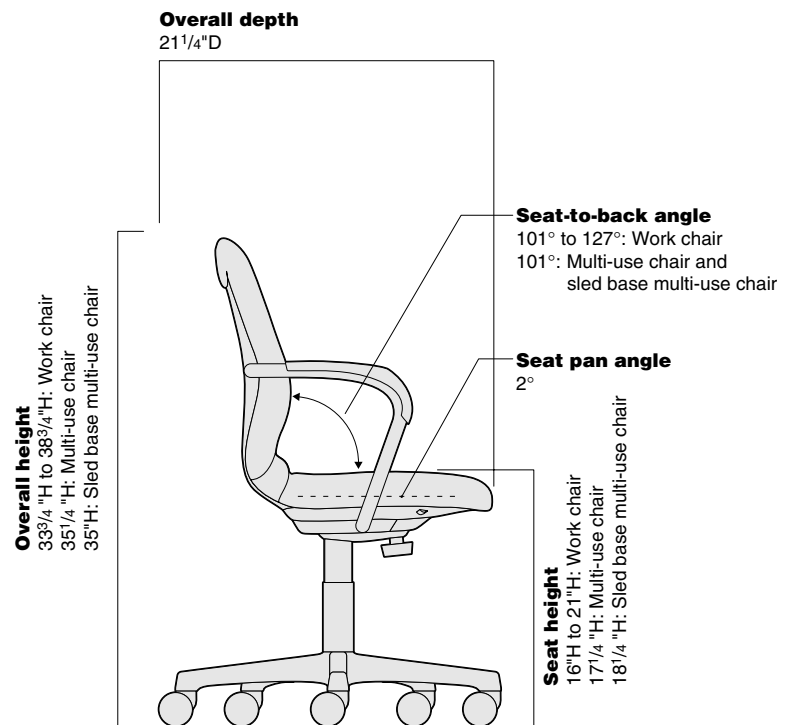
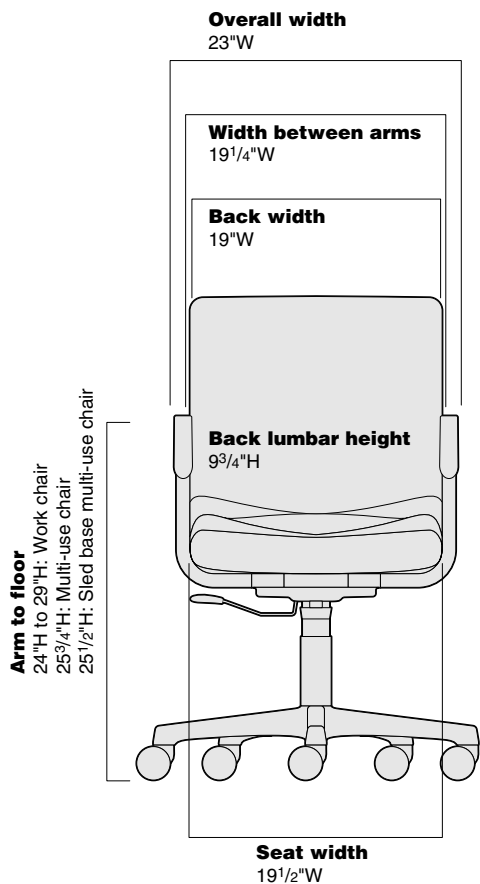

• Back Lumbar Height	• Width Between Arms	• Arm to Floor	• Arm Height from Seat	• Seat Pan Angle	• Angle Between Seat and Back
----------------------	----------------------	----------------	------------------------	------------------	-------------------------------

Work Chairs

9¾"	19¼"	24"-29"	7¾"	2°	101°-127°
-----	------	---------	-----	----	-----------

Multi-Use Chairs

9¾"	19¼"	25¾"	7¾"	2°	101°
9¾"	19¼"	25½"	7¾"	2°	101°

Protegé 433 Series Work Chairs



	Standard Includes	Required to Specify
▶ Need help? Product details, page 170	<ul style="list-style-type: none"> Advanced swivel-tilt mechanism Arms, if selected: plastic color to match base Outer back: plastic color Back tension adjustment Upholstery: fabric price group 1 Five-arm base: plastic color 2½"-diameter, hard composition, dual-wheel casters: plastic color to match base 	<ol style="list-style-type: none"> Style number Plastic color number for base, outer back, arms, and casters Fabric color number for upholstery Options, if selected (see below) <p>▶ See <i>Surface Materials</i>, page 282.</p>

	Options	U.S. Price	Required to Specify
Surface Materials	Upholstery		
	• Fabric price group 1	No cost	Specify fabric color number.
	• Fabric price group 2	+\$ 20	Specify fabric color number.
	• Fabric price group 3	+\$ 40	Specify fabric color number.
	• Fabric price group 4	+\$ 55	Specify fabric color number.
	• Fabric price group 5	+\$ 70	Specify fabric color number.
	• Fabric price group 6	+\$100	Specify fabric color number.
	• Fabric price group 7	+\$140	Specify fabric color number.
	• Fabric price group 8	+\$185	Specify fabric color number.
	• Fabric price group 9	+\$220	Specify fabric color number.
• Fabric price group 10	+\$255	Specify fabric color number.	
• Customer's Own Material (COM)	+\$ 30	▶ See <i>Surface Materials Reference Manual</i> to specify.	
• Steelcase leather upholstery	+\$542	Add suffix S to style number and specify leather color number.	
• Customer's Own Leather (COL)	+\$311	Add suffix S to style number.	
		▶ See <i>Surface Materials Reference Manual</i> to specify.	
	• Fire Code Seating (FCS)	+\$ 50	Add suffix F to the style number.
	• Soil-retardant treatment applied to upholstery fabric	+\$ 17	Specify <i>with soil-retardant treatment</i> .
	Fully upholstered		
	• Fabric fully upholstered outer back and outer seat	+\$ 88	Add suffix U to the style number.
	• Steelcase leather fully upholstered outer back and outer seat	+\$944	Add suffix SU to the style number and specify leather color number.
	• Customer's Own Leather (COL) fully upholstered outer back and outer seat	+\$484	Add suffix SU to the style number.
			▶ See <i>Surface Materials Reference Manual</i> to specify.
Casters	• Soft, dual-wheel casters	+\$ 18	Specify <i>with soft casters</i> .

Tip: Always add suffixes in alphabetical order when specifying options to Protegé seating.

Tip: Fire Code Seating (FCS) option is available with certain upholstery fabric choices only.

▶ Pages 289–290

▶ Detailed dimensions, page 172



For Canadian Pricing
Multiply U.S. Price by 1.38.

▶ See page 1 for details.

Specification Information

Arms



• **Style Number**
• **U.S. Base Price**

Arms with Soft Arm Caps



• **Style Number**
• **U.S. Base Price**

Pneumatic

4331213 \$560

4331223 \$584

Pneumatic with Upright Back Lock

4331413 \$600

4331423 \$624

Without Arms



• **Style Number**
• **U.S. Base Price**

Pneumatic

4331203 \$529

Pneumatic with Upright Back Lock

4331403 \$569



For Canadian Pricing
Multiply U.S. Price by 1.38.
▶ See page 1 for details.

Protegé 433 Series Multi-Use Chairs



	Standard Includes	Required to Specify
<ul style="list-style-type: none"> ▶ Need help? Product details, page 170 	<ul style="list-style-type: none"> • Fixed height with advanced swivel-tilt mechanism • Arms, if selected: plastic color to match base • Outer back: plastic color • Back tension adjustment • Upholstery: fabric price group 1 • Five-arm base: plastic color • 2½"-diameter, hard composition, dual-wheel casters: plastic color to match base 	<ol style="list-style-type: none"> 1 Style number 2 Plastic color number for base, outer back, arms, and casters 3 Fabric color number for upholstery 4 Options, if selected (see below) <ul style="list-style-type: none"> ▶ See <i>Surface Materials</i>, page 282.

	Options	U.S. Price	Required to Specify
Surface Materials	Upholstery		
	• Fabric price group 1	No cost	Specify fabric color number.
	• Fabric price group 2	+\$ 20	Specify fabric color number.
	• Fabric price group 3	+\$ 40	Specify fabric color number.
	• Fabric price group 4	+\$ 55	Specify fabric color number.
	• Fabric price group 5	+\$ 70	Specify fabric color number.
	• Fabric price group 6	+\$100	Specify fabric color number.
	• Fabric price group 7	+\$140	Specify fabric color number.
	• Fabric price group 8	+\$185	Specify fabric color number.
	• Fabric price group 9	+\$220	Specify fabric color number.
• Fabric price group 10	+\$255	Specify fabric color number.	
• Customer's Own Material (COM)	+\$ 30	▶ See <i>Surface Materials Reference Manual</i> to specify.	
• Steelcase leather upholstery	+\$542	Add suffix S to style number and specify leather color number.	
• Customer's Own Leather (COL)	+\$311	Add suffix S to style number.	
		▶ See <i>Surface Materials Reference Manual</i> to specify.	
	• Fire Code Seating (FCS)	+\$ 50	Add suffix F to the style number.
	• Soil-retardant treatment applied to upholstery fabric	+\$ 17	Specify <i>with soil-retardant treatment</i> .
	Fully upholstered		
	• Fabric fully upholstered outer back and outer seat	+\$ 88	Add suffix U to the style number.
	• Steelcase leather fully upholstered outer back and outer seat	+\$944	Add suffix SU to the style number and specify leather color number.
	• Customer's Own Leather (COL) fully upholstered outer back and outer seat	+\$484	Add suffix SU to the style number.
			▶ See <i>Surface Materials Reference Manual</i> to specify.
Casters	• Soft, dual-wheel casters	+\$ 18	Specify <i>with soft casters</i> .

Tip: Always add suffixes in alphabetical order when specifying options to Protegé seating.

Tip: Fire Code Seating (FCS) option is available with certain upholstery fabric choices only.

▶ Pages 289–290

▶ Detailed dimensions, page 172



For Canadian Pricing
Multiply U.S. Price by 1.38.

▶ See page 1 for details.

Specification Information

Arms



• **Style Number**
:
:
:
:
:

• **U.S. Base Price**
:
:
:
:
:

Arms with Soft Arm Caps



• **Style Number**
:
:
:
:
:

• **U.S. Base Price**
:
:
:
:
:

Multi-Use Chairs

Fixed Height

4333013	\$533	4333023	\$557
•	•	•	•
•	•	•	•
•	•	•	•
•	•	•	•

Without Arms



• **Style Number**
:
:
:
:
:

• **U.S. Base Price**
:
:
:
:
:

Multi-Use Chairs

Fixed Height

4333003	\$502
•	•
•	•
•	•
•	•



For Canadian Pricing
Multiply U.S. Price by 1.38.
▶ See page 1 for details.

Understanding and Specifying Cachet 487 Series Work Chairs

Understanding Cachet 487 Series

Details	180
Dimensions	182

Specifying Cachet 487 Series

Swivel-Base Work Chairs	184
Leg-Base Multi-Use Chairs	186
Cushion Upholstery Packages	188
Accessories	191

Work Chairs

Cachet offers basic ergonomic comfort for people who have varied tasks and tend to be in and out of the office during the day. Features include adjustable seat height and a unique Balanced-Action Rocker (BAR) mechanism that allows users to recline easily without a manual adjustment. Also featured is the no front-rise seat—in other words, when you lean back, the front edge of the seat doesn't rise up, lifting your legs off the floor and cutting off circulation.

- Rally 457 Series
- Protégé 433 Series
- Cachet 487 Series

Cachet 487 Series

Cachet chairs are lightweight, extremely comfortable, multipurpose chairs with a unique Balanced-Action Rocker (BAR) mechanism that allows the chair to recline in response to the user's weight.

Flexible, contoured back and seat have parallel slats that conform to individual users.

Nylon injection-molded tubular frame provides strength with minimal weight.

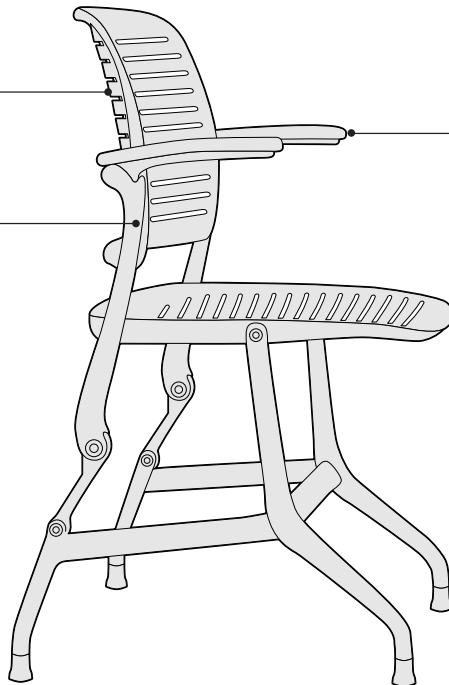

Flip-up arms easily lift to move out of the way or to allow for stacking.

Product Details

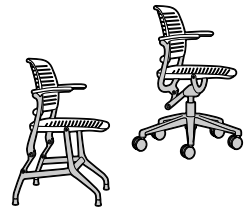

Chair bases are available in two styles—fixed-height four leg and adjustable-height swivel.



Balanced-action rocker (BAR) mechanism allows the user to recline for optimum comfort.



Upholstered cushions are available for use on chair back and seat. Cushions can be specified for factory installation or ordered separately for field installation. When specified with the chair, cushions are available for seat and back, or seat only. When ordered separately, cushions are available for seat and back, seat only, or back only. The cushions attach to the slats of back and seat.

Tip: You must specify plastic outer back color to match chair.

Hard plastic glides are standard on leg-base chairs.

Balanced-action rocker (BAR) mechanism allows every user to fully recline.

Five-arm base is standard.



Seat height adjusts within a 5" range (15½"H to 20½"H) with a pneumatic-adjustment mechanism.

Hard, dual-wheel casters are provided for use on carpets. Soft, dual-wheel casters are available for use on hard floors.

Soft glides are available as an option for use on non-carpeted surfaces. The soft glide is reversible—soft on one side, hard on the other.

Leg-base chairs stack five high on the floor and 20 high on the dolly.

Leg-base chairs are available with or without flip-up arms. Chairs with or without arms can be stacked.

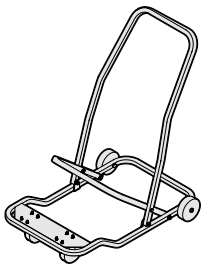

Transport and storage dolly is available to stack, move, and store up to 20 leg-base chairs. Swivel-base chairs will not stack.

Unloaded transport dolly measures 48"D x 23"W x 38³/₄"H.

Fully loaded transport dolly measures 51"D x 23"W x 78³/₄"H.

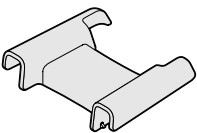

Ganging and alignment device is available to link leg-base chairs together in the field for evenly spaced rows. Chairs can be separated easily. Spacing between chairs linked with alignment device is 2".

Tip: You must specify plastic color of ganging and alignment device to match chairs.

Cachet is recommended for indoor use only.

Surface Materials

▶ See surface materials on page 282 for specific availability or refer to the *Surface Materials Reference Manual* for further information.

Hard components

(frame, flip-up arms, back, seat, and base)

- Plastic color

Upholstery

- Fabric
- Fabric with soil-retardant treatment (option)
- Leather
- Vinyl

Glides

- Color-matched plastic on leg-base chair
- Color-matched soft plastic (option)

Casters

- Hard, black plastic wheels on swivel-base chair
- Soft, black plastic wheels (option)

All Steelcase seating with standard upholstery fabrics complies with requirements of the BIFMA First Generation Voluntary Upholstered Furniture Flammability Standard, as well as the State of California Technical Bulletin 117. All standard seating is labeled to be in compliance with California TB117.

Programs & Services

▶ See the *Surface Materials Reference Manual* for further detail about programs and services offered for seating.

The Customer's Own Material (COM) Program

offers the opportunity for customers to select fabrics that are not offered through the standard Steelcase surface materials program for use on Steelcase products. Through the COM program, Steelcase will test your materials for application on Steelcase products. Once approved, you can place your order. Steelcase will facilitate the entire ordering process and give you a production schedule. Steelcase will order the COM fabric directly from the textile manufacturer. For up-to-date information regarding fabric test results for all COM fabrics and details regarding yardage requirements for most Seating lines, visit the COM Web site. To locate the COM Web site:

- Visit www.steelcase.com
- Click on "Knowledge & Design"
- Select "Customer's Own Material"

Soil retardants are treatments that provide long-term soil and stain resistance to a fabric without affecting the shade or the integrity of the fabric. The following Steelcase Textiles are available pre-treated with soil retardant. (You do not need to select the soil-retardant option for these fabrics and incur the \$17 upcharge.)

- Canzoné
- Cavalcade
- Jacks
- Link
- Regis
- Rook
- Roulette
- Skittles
- Spyder
- Sweepstakes

Soil-retardant treatment is available on all other seating fabrics at an additional \$17 U.S. per seating unit. To order this option, please select "Soil-Retardant Treatment" under "Optional Accessories."

For soil-retardant treatment on COMs, please select "Soil-Retardant Treatment" under "Optional Accessories." Minimums or additional yardage may be required. Please contact the vendor directly for specific information.

Extended lead times may be necessary for this service.

Contact your Steelcase Sales Service representative at 1.888.STEELCASE (1.888.783.3522).

Fire Codes

▶ See pages 289–290 for upholstery fabrics available for use with FCS modification.

Fire Code Seating (FCS) option

is available on non-upholstered models. FCS is also available on upholstered models with certain fabric choices only. ▶ See *Surface Materials*, page 282.

Steelcase offers Fire Code Seating modification (FCS) on nearly all seating models. The most rigorous fire codes in the nation have been developed in California, and the Steelcase FCS modification is designed to meet those codes. Fire Code Seating (FCS) indicates that a product is constructed to meet the strict fire code requirements of high public occupancy areas such as theaters, meeting rooms, and lobbies. The FCS standards will meet both the State of California Home Furnishing Technical Bulletin 133 (Cal TB 133) and Boston Fire Code (BFC). Boston adopted the California Home Furnishing Technical Bulletin TB 133 test standard in 1992.

Local codes may have special requirements for upholstery.

Dimensions

▶ Page 182

Resources

Printed Materials

- ▶ Cachet Product Brochure (S11527)
- ▶ Anatomy of a Design (S11473)
- ▶ Sales and Dealer Guide on in2.steelcase.com
- ▶ Plastic Swatch Card (S8752)
- ▶ Seating Overview (03-0003368)

Dimensions

Cachet 487 Series

Features	Overall Depth	Width	Height	Seat Depth	Functional Seat Depth	Seat Width*	Seat Height from Floor	Back Width	Back Height from Seat	Back Lumbar Height
Cachet 487 Series										
Leg-Base Multi-Use Chairs										
Fixed-Height	20½"	23"	34¼"	19¾"	16⅞"	16⅜"	17⅝"	18½"	18¾"	8"
Swivel-Base Work Chairs										
Pneumatic	25"	25"	32⅛"– 37⅛"	19¾"	16⅞"	16⅜"	15½"– 20½"	18½"	18¾"	8"

* **Seat width dimension** is taken close to the front edge of the seat. The dimension closer to the actual sitting surface is 19".

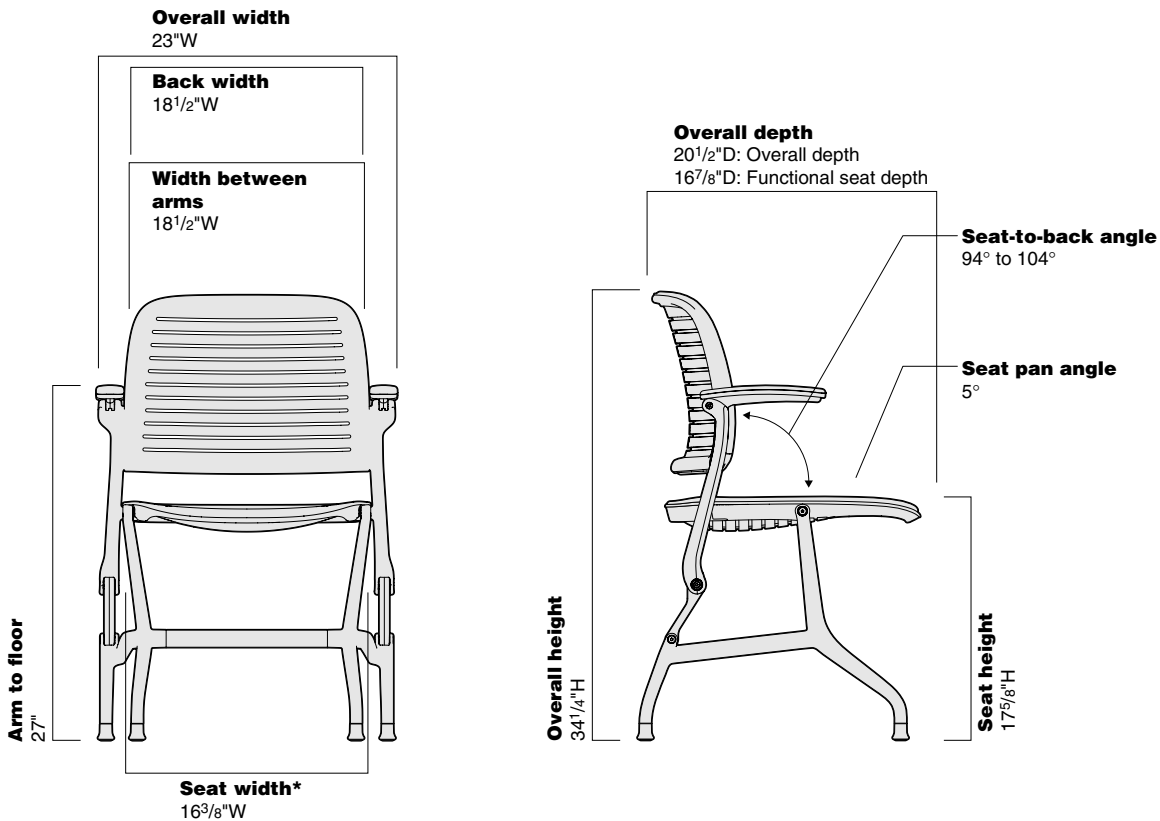

Leg-Base Multi-Use Chair

Width Between Arms	Arm to Floor	Arm Height from Seat	Seat Pan Angle	Angle Between Seat and Back
--------------------	--------------	----------------------	----------------	-----------------------------

Leg-Base Multi-Use Chairs

18 1/2"	27"	10 3/4"	5°	94°-104°
---------	-----	---------	----	----------

Swivel-Base Work Chairs

18 1/2"	25"-30"	10 3/4"	5°	94°-107°
---------	---------	---------	----	----------

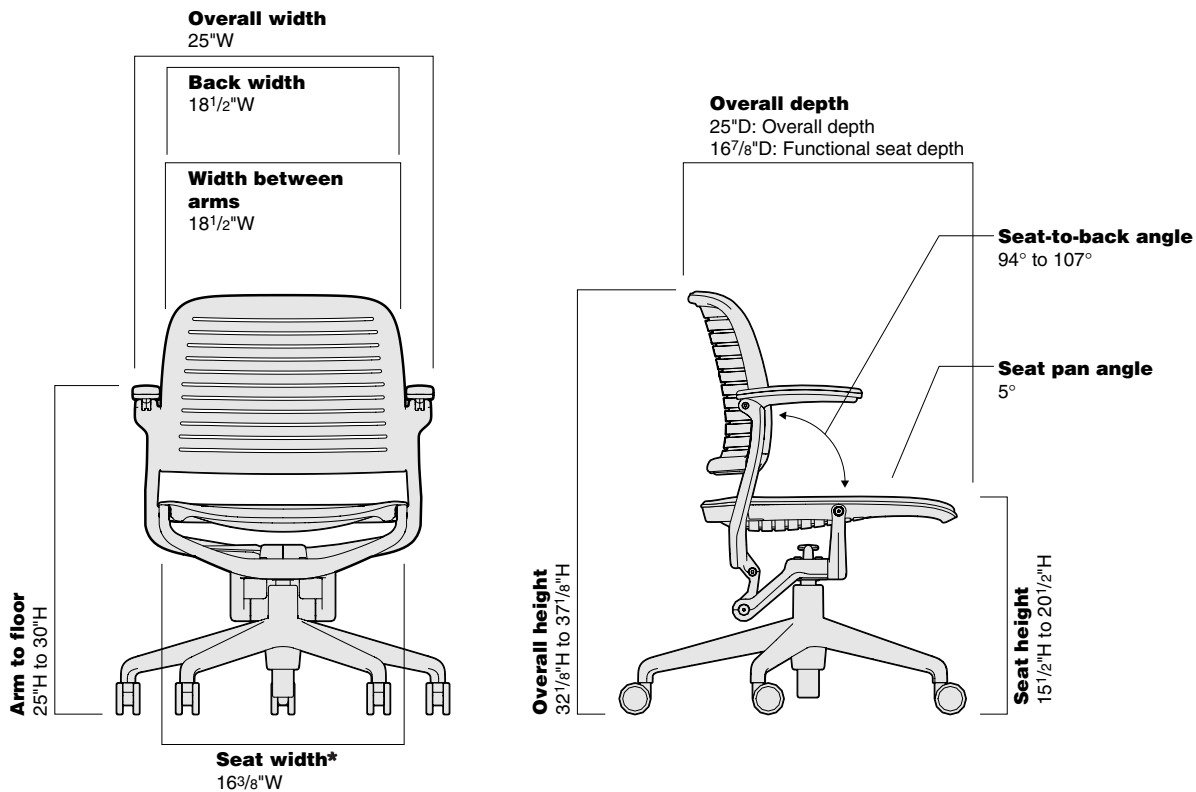

Swivel-Base Work Chair

Cachet 487 Series Swivel-Base Work Chairs



	Standard Includes	Required to Specify
▶ Need help? Product details, page 180	<ul style="list-style-type: none"> Balanced-action rocker (BAR) mechanism Frame, seat, back, flip-up arms, and five-arm base: plastic 5" pneumatic seat-height adjustment Upholstery, if selected: fabric price group 1 2$\frac{3}{8}$" diameter, hard composition, dual-wheel casters: black plastic 	<ol style="list-style-type: none"> Style number Plastic color number for frame, seat, back, flip-up arms, and five-arm base Fabric color number for upholstery on seat and back, or seat, if selected Options, if selected (see below) <p>▶ See <i>Surface Materials</i>, page 282.</p>

Tip: Fire Code Seating (FCS) option is available on non-upholstered models. FCS is also available on upholstered models with certain fabric choices only.

▶ Pages 289–290

	Options	U.S. Price	Required to Specify
Surface Materials	Non-upholstered chair		
	• Fire Code Seating (FCS)	+\$ 30	Add suffix F to the style number.
	Upholstery on seat		
	• Fabric price group 1	No cost	Specify fabric color number.
	• Fabric price group 2	+\$ 10	Specify fabric color number.
	• Fabric price group 3	+\$ 20	Specify fabric color number.
	• Fabric price group 4	+\$ 28	Specify fabric color number.
	• Fabric price group 5	+\$ 35	Specify fabric color number.
	• Fabric price group 6	+\$ 43	Specify fabric color number.
	• Fabric price group 7	+\$ 50	Specify fabric color number.
• Fabric price group 8	+\$ 63	Specify fabric color number.	
• Fabric price group 9	+\$ 78	Specify fabric color number.	
• Fabric price group 10	+\$ 88	Specify fabric color number.	
• Customer's Own Material (COM)	No cost	▶ See <i>Surface Materials Reference Manual</i> to specify.	
• Steelcase leather upholstery	+\$ 75	Add suffix S to the style number and specify leather color number.	
• Customer's Own Leather (COL)	No cost	Add suffix S to the style number and specify leather color number.	
		▶ See <i>Surface Materials Reference Manual</i> to specify.	
	• Fire Code Seating (FCS)	+\$ 40	Add suffix F to the style number.
	• Soil-retardant treatment applied to upholstery fabric	+\$ 17	Specify <i>with soil-retardant treatment</i> .
	Upholstery on seat and back		
	• Fabric price group 1	No cost	Specify fabric color number.
	• Fabric price group 2	+\$ 20	Specify fabric color number.
	• Fabric price group 3	+\$ 40	Specify fabric color number.
	• Fabric price group 4	+\$ 55	Specify fabric color number.
	• Fabric price group 5	+\$ 70	Specify fabric color number.
	• Fabric price group 6	+\$ 85	Specify fabric color number.
	• Fabric price group 7	+\$100	Specify fabric color number.
	• Fabric price group 8	+\$125	Specify fabric color number.
	• Fabric price group 9	+\$155	Specify fabric color number.
	• Fabric price group 10	+\$175	Specify fabric color number.
	• Customer's Own Material (COM)	No cost	▶ See <i>Surface Materials Reference Manual</i> to specify.
	• Steelcase leather upholstery	+\$150	Add suffix S to the style number and specify leather color number.
	• Customer's Own Leather (COL)	No cost	Add suffix S to the style number and specify leather color number.
			▶ See <i>Surface Materials Reference Manual</i> to specify.
	• Fire Code Seating (FCS)	+\$ 50	Add suffix F to the style number.
	• Soil-retardant treatment applied to upholstery fabric	+\$ 17	Specify <i>with soil-retardant treatment</i> .
Casters	• Soft, dual-wheel casters for use on hard floors: black plastic	+\$ 18	Specify <i>with soft casters</i> .

▶ Detailed dimensions, page 182



For Canadian Pricing
Multiply U.S. Price by 1.38.
▶ See page 1 for details.

Specification Information

Without Upholstery



• **Style Number**
• **U.S. Base Price**

4871110 \$500

With Upholstered Seat



• **Style Number**
• **U.S. Base Price**

4871210 \$600

With Upholstered Seat and Back



• **Style Number**
• **U.S. Base Price**

4871211 \$650



For Canadian Pricing
Multiply U.S. Price by 1.38.
▶ See page 1 for details.

Cachet 487 Series Leg-Base Multi-Use Chairs

Without Arms or with Flip-Up Arms



Tip: Fire Code Seating (FCS) option is available on non-upholstered models. FCS is also available on upholstered models with certain fabric choices only.

▶ Pages 289–290

▶ Detailed dimensions, page 182



For Canadian Pricing
Multiply U.S. Price by 1.38.
▶ See page 1 for details.

Standard Includes	Required to Specify
<ul style="list-style-type: none"> ▶ Need help? Product details, page 180 • Balanced-action rocker (BAR) mechanism • Frame, seat, back, and four-leg base: plastic • Flip-up arms, if selected: plastic color to match frame, seat, and four-leg base • Upholstery, if selected: fabric price group 1 • Hard glides: color-matched to frame 	<ol style="list-style-type: none"> 1 Style number 2 Plastic color number for frame, seat, back, four-leg base, and flip-up arms, if selected 3 Fabric color number for upholstery on seat and back, or seat, if selected 4 Options, if selected (see below) <p>▶ See <i>Surface Materials</i>, page 282.</p>

Options	U.S. Price	Required to Specify
<p>Surface Materials</p> <ul style="list-style-type: none"> • Fire Code Seating (FCS) +\$ 30 		Add suffix F to the style number.
<p>Upholstery on seat</p> <ul style="list-style-type: none"> • Fabric price group 1 No cost • Fabric price group 2 +\$ 10 • Fabric price group 3 +\$ 20 • Fabric price group 4 +\$ 28 • Fabric price group 5 +\$ 35 • Fabric price group 6 +\$ 43 • Fabric price group 7 +\$ 50 • Fabric price group 8 +\$ 63 • Fabric price group 9 +\$ 78 • Fabric price group 10 +\$ 88 • Customer's Own Material (COM) No cost • Steelcase leather upholstery +\$ 75 • Customer's Own Leather (COL) No cost • Fire Code Seating (FCS) +\$ 40 • Soil-retardant treatment applied to upholstery fabric +\$ 17 		<p>Specify fabric color number.</p> <p>Specify fabric color number.</p> <p>Specify fabric color number.</p> <p>Specify fabric color number.</p> <p>Specify fabric color number.</p> <p>Specify fabric color number.</p> <p>Specify fabric color number.</p> <p>Specify fabric color number.</p> <p>Specify fabric color number.</p> <p>▶ See <i>Surface Materials Reference Manual</i> to specify.</p> <p>Add suffix S to the style number and specify leather color number.</p> <p>Add suffix S to the style number and specify leather color number.</p> <p>▶ See <i>Surface Materials Reference Manual</i> to specify.</p> <p>Add suffix F to the style number.</p> <p>Specify <i>with soil-retardant treatment</i>.</p>
<p>Upholstery on seat and back</p> <ul style="list-style-type: none"> • Fabric price group 1 No cost • Fabric price group 2 +\$ 20 • Fabric price group 3 +\$ 40 • Fabric price group 4 +\$ 55 • Fabric price group 5 +\$ 70 • Fabric price group 6 +\$ 85 • Fabric price group 7 +\$100 • Fabric price group 8 +\$125 • Fabric price group 9 +\$155 • Fabric price group 10 +\$175 • Customer's Own Material (COM) No cost • Steelcase leather upholstery +\$150 • Customer's Own Leather (COL) No cost • Fire Code Seating (FCS) +\$ 50 • Soil-retardant treatment applied to upholstery fabric +\$ 17 		<p>Specify fabric color number.</p> <p>Specify fabric color number.</p> <p>Specify fabric color number.</p> <p>Specify fabric color number.</p> <p>Specify fabric color number.</p> <p>Specify fabric color number.</p> <p>Specify fabric color number.</p> <p>Specify fabric color number.</p> <p>Specify fabric color number.</p> <p>▶ See <i>Surface Materials Reference Manual</i> to specify.</p> <p>Add suffix S to the style number and specify leather color number.</p> <p>Add suffix S to the style number and specify leather color number.</p> <p>▶ See <i>Surface Materials Reference Manual</i> to specify.</p> <p>Add suffix F to the style number.</p> <p>Specify <i>with soil-retardant treatment</i>.</p>
<p>Glides</p> <ul style="list-style-type: none"> • Soft glides: color matched to frame +\$ 10 		Specify <i>with soft glides</i> .

Specification Information

Without Upholstery



• Style
 Number

• U.S.
 Base
 Price

With Upholstered Seat



• Style
 Number

• U.S.
 Base
 Price

With Upholstered Seat and Back



• Style
 Number

• U.S.
 Base
 Price

Without Arms

4878100

\$300

4878200

\$400

4878201

\$450

Without Upholstery



• Style
 Number

• U.S.
 Base
 Price

With Upholstered Seat



• Style
 Number

• U.S.
 Base
 Price

With Upholstered Seat and Back



• Style
 Number

• U.S.
 Base
 Price

With Flip-Up Arms

4878110

\$380

4878210

\$480

4878211

\$530



For Canadian Pricing
 Multiply U.S. Price by 1.38.
 ▶ See page 1 for details.

Cushion Upholstery Packages

Cushion Upholstery Package for Back and Seat

for Use on Leg-Base and Swivel Models

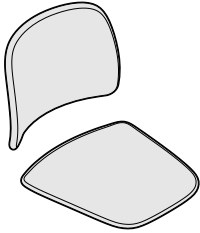

Tip: To comply with FCS requirements, both the chair and the cushion(s) must be specified with the FCS option.

Standard Includes	Required to Specify
-------------------	---------------------

- Package of one seat and one back cushion
- Cushion upholstery for seat and back: fabric price group 1
- Outer back: plastic to match chair

- 1 Style number
 - 2 Fabric color number
 - 3 Specify plastic color of back to match chair
 - 4 Options, if selected (see below)
- ▶ See *Surface Materials*, page 282.

Surface Materials	Options	U.S. Price	Required to Specify
-------------------	---------	------------	---------------------

Surface Materials	• Fabric price group 1	No cost	Specify fabric color number.
	• Fabric price group 2	+\$ 20	Specify fabric color number.
	• Fabric price group 3	+\$ 40	Specify fabric color number.
	• Fabric price group 4	+\$ 55	Specify fabric color number.
	• Fabric price group 5	+\$ 70	Specify fabric color number.
	• Fabric price group 6	+\$ 85	Specify fabric color number.
	• Fabric price group 7	+\$100	Specify fabric color number.
	• Fabric price group 8	+\$125	Specify fabric color number.
	• Fabric price group 9	+\$155	Specify fabric color number.
	• Fabric price group 10	+\$175	Specify fabric color number.
	• Customer's Own Material (COM)	No cost	▶ See <i>Surface Materials Reference Manual</i> to specify.
	• Steelcase leather upholstery	+\$150	Add suffix S to the style number and specify leather color number.
• Customer's Own Leather (COL)	No cost	Add suffix S to the style number and specify leather color number.	
• Fire Code Seating (FCS)	+\$ 20	▶ See <i>Surface Materials Reference Manual</i> . Add suffix F to the style number.	
• Soil-retardant treatment	+\$ 17	Specify <i>with soil-retardant treatment</i> .	

Specification Information

Style Number	U.S. Base Price

Package of 1 Back Cushion and 1 Seat Cushion

487STBK	\$225

▶ Detailed dimensions, page 182



For Canadian Pricing
Multiply U.S. Price by 1.38.
▶ See page 1 for details.

Cushion Upholstery Package for Back

for Use on Leg-Base and Swivel Models

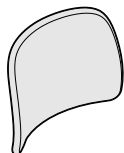

Standard Includes	Required to Specify
-------------------	---------------------

- | | |
|---|--|
| Standard Includes | Required to Specify |
| <ul style="list-style-type: none"> • One back cushion • Cushion upholstery for back: fabric price group 1 • Outer back: plastic to match chair | <ol style="list-style-type: none"> 1 Style number 2 Fabric color number for cushion 3 Specify plastic color of back to match chair 4 Options, if selected (see below) <p>▶ See <i>Surface Materials</i>, page 282.</p> |

Options	U.S. Price	Required to Specify
---------	------------	---------------------

Options	U.S. Price	Required to Specify
Surface Materials		
• Fabric price group 1	No cost	Specify fabric color number.
• Fabric price group 2	+\$10	Specify fabric color number.
• Fabric price group 3	+\$20	Specify fabric color number.
• Fabric price group 4	+\$28	Specify fabric color number.
• Fabric price group 5	+\$35	Specify fabric color number.
• Fabric price group 6	+\$43	Specify fabric color number.
• Fabric price group 7	+\$50	Specify fabric color number.
• Fabric price group 8	+\$63	Specify fabric color number.
• Fabric price group 9	+\$78	Specify fabric color number.
• Fabric price group 10	+\$88	Specify fabric color number.
• Customer's Own Material (COM)	No cost	▶ See <i>Surface Materials Reference Manual</i> to specify.
• Steelcase leather upholstery	+\$75	Add suffix S to the style number and specify leather color number.
• Customer's Own Leather (COL)	No cost	Add suffix S to the style number and specify leather color number.
• Fire Code Seating (FCS)	+\$10	▶ See <i>Surface Materials Reference Manual</i> . Add suffix F to the style number.
• Soil-retardant treatment	+\$17	Specify <i>with soil-retardant treatment</i> .

Tip: To comply with FCS requirements, both the chair and the cushion(s) must be specified with the FCS option.

Specification Information

Style Number	U.S. Base Price
487BK	\$125



For Canadian Pricing
 Multiply U.S. Price by 1.38.
 ▶ See page 1 for details.

Cushion Upholstery Package for Seat

for Use on Leg-Base and Swivel Models

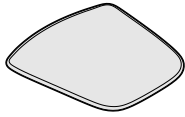

Standard Includes	Required to Specify
-------------------	---------------------

- One seat cushion
- Cushion upholstery for seat: fabric price group 1

- 1 Style number
 - 2 Fabric color number for cushion
 - 3 Options, if selected (see below)
- ▶ See *Surface Materials*, page 282.

Surface Materials	Options	U.S. Price	Required to Specify
-------------------	---------	------------	---------------------

Surface Materials

- | Options | U.S. Price |
|---------------------------------|------------|
| • Fabric price group 1 | No cost |
| • Fabric price group 2 | +\$10 |
| • Fabric price group 3 | +\$20 |
| • Fabric price group 4 | +\$28 |
| • Fabric price group 5 | +\$35 |
| • Fabric price group 6 | +\$43 |
| • Fabric price group 7 | +\$50 |
| • Fabric price group 8 | +\$63 |
| • Fabric price group 9 | +\$78 |
| • Fabric price group 10 | +\$88 |
| • Customer's Own Material (COM) | No cost |
| • Steelcase leather upholstery | +\$75 |
| • Customer's Own Leather (COL) | No cost |
| • Fire Code Seating (FCS) | +\$10 |
| • Soil-retardant treatment | +\$17 |

- Specify fabric color number.
Specify fabric color number.
Specify fabric color number.
Specify fabric color number.
Specify fabric color number.
Specify fabric color number.
Specify fabric color number.
Specify fabric color number.
Specify fabric color number.
Specify fabric color number.
▶ See *Surface Materials Reference Manual* to specify.
Add suffix **S** to the style number and specify leather color number.
Add suffix **S** to the style number and specify leather color number.
▶ See *Surface Materials Reference Manual*.
Add suffix **F** to the style number.
Specify *with soil-retardant treatment*.

Tip: To comply with FCS requirements, both the chair and the cushion(s) must be specified with the FCS option.

Specification Information	
---------------------------	--

Style Number	U.S. Base Price
487ST	\$125

▶ Detailed dimensions, page 182



For Canadian Pricing
Multiply U.S. Price by 1.38.
▶ See page 1 for details.

Transport and Storage Dolly

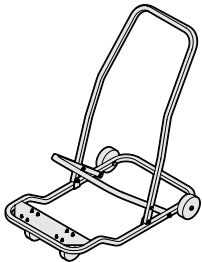

Tip: Transport and storage dolly is for leg-base chairs only.

Standard Includes	Required to Specify
<ul style="list-style-type: none"> ▶ Need help? Product details, page 181 • Transport and storage dolly: black paint only 	<ul style="list-style-type: none"> Style number

Specification Information

Style Number	U.S. Price
487D	\$400
.	.

Ganging and Alignment Devices

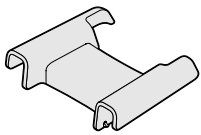

Tip: Ganging and alignment devices are for leg-base chairs only.

Standard Includes	Required to Specify
<ul style="list-style-type: none"> ▶ Need help? Product details, page 181 • Carton of 5 devices: color matched to frame 	<ul style="list-style-type: none"> 1 Style number 2 Plastic color number to match chair ▶ See <i>Surface Materials</i>, page 282.

Specification Information

Style Number	U.S. Price
487G	\$40
.	.



For Canadian Pricing
Multiply U.S. Price by 1.38.
▶ See page 1 for details.



Understanding and Specifying Leap 462 Series High Density Work Chairs

Leap High Density (HD) chairs and stools are scaled to allow a seat width 1" narrower than Leap 462 Series Work Chairs while reducing overall lateral width by 4". Plan with Leap HD for environments where space constraints are an issue. ▶ See page 198 for specific dimensional comparisons.

Understanding Leap 462 Series High Density

Details	194
Dimensions	198

Specifying Leap 462 Series High Density

Ribbon Backframe Work Chairs

Standard Upholstery on Back and Seat	200
Pillowed Upholstery on Back and Seat	202
Bare-Back and Standard Upholstery on Seat	204
Bare-Back and Pillowed Upholstery on Seat	206

Ribbon Backframe Stools

Standard Upholstery on Back and Seat	208
Pillowed Upholstery on Back and Seat	210
Bare-Back and Standard Upholstery on Seat	212
Bare-Back and Pillowed Upholstery on Seat	214

Pillowed Upholstery Packages

Vest Packages	219
---------------	-----

Work Chairs

Highly adjustable task seating offers maximum personalization for people who sit most of the day performing repetitive tasks. By making a series of simple adjustments, you can customize the chair to your body, preferences, and tasks. These chairs provide continuous, stable, task-oriented comfort, and can be quickly adjusted to support you in upright, forward, and reclining work postures.

- Leap 462 Series
- Leap 464 Series WorkLounge
- Criterion 453 Series
- Drive 461 Series
- Jersey Series
- Sensor 458 Series

Adjustability Features

- ▶ See page 11 for a comparison to other chairs. **Leap 462 Series HD**

Mechanisms

Natural glide ●

Seat Adjustments

Pneumatic height ●

Seat edge angle ●

Seat depth ●

Back Adjustments

Lumbar height ●

Lower back firmness ●

Upper back tension ●

Variable back stop ●

Arm Adjustments

Arm height ●

Arm width ●

Arm pivot ●

Leap 462 Series High Density

Leap High Density (HD)

chairs and stools are scaled to allow a seat width 1" narrower than Leap 462 Series Work Chairs while reducing overall lateral width by 4". Plan with Leap HD for environments where space constraints are an issue.

▶ See page 198 for specific dimensional comparisons.

Outer back and outer seat are plastic.

Lumbar height 5" of additional lower back support is available as an option on chairs and stools with standard upholstery only.

Arm height can adjust independently within a 4" range to help relieve upper back and shoulder fatigue.

Seat depth adjusts within a 3" range on work chairs. Stools adjust within a 2¼" range. Fixed seat depth models are also available.

Five-arm base is standard.

Casters have hard, dual-wheels that roll smoothly on carpets. They are 3" for increased mobility. Soft, dual-wheel casters are available for use on hard floors or chair mats. Stools are standard with 2" hard casters. Soft casters are available as an option.

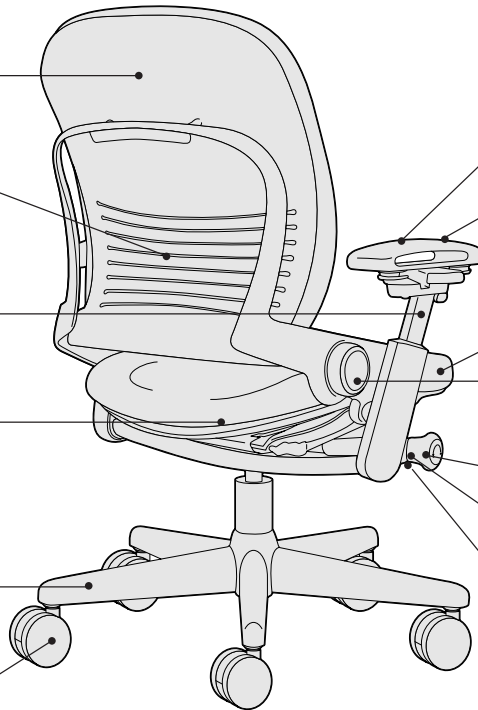

Arm width can adjust within a 2½" range for each arm to provide forearm support in neutral position.

Arm caps can pivot independently 12° in and 21° out to accommodate individual user preferences.

Seat edge angle allows the front edge of the seat to drop down close to 2", relieving pressure behind the thighs.

Lower back firmness changes the amount of firmness user feels in lower back. Requires only two complete turns.

Upper back force requires only five complete turns and accommodates a broader range of users by allowing user to change the rate of increase in force as the user reclines.

Seat height on chairs adjusts within a 5" range with a pneumatic adjustment mechanism. A 7" range is available as an option. Stools have an 8" range.

Variable back stop with five positions is standard.

Product Details

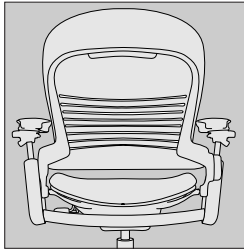

Parallel slats in back shell provide extensive flexibility to allow back to conform to individual users.

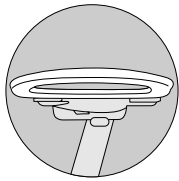

HD arm

- Soft urethane, see-through

Models are available with fixed seats or with adjustable seats which include seat depth and seat edge angle.

Adjustability instructions are included with every chair.

Controls under the seat include tactile braille designers.

Adjustment Features

Seat Adjustments

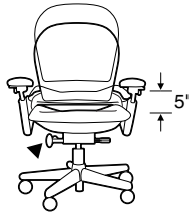

Seat height adjusts pneumatically. To lower, hold handle up while seated. To raise, hold handle up and keep your weight off the chair. Range of adjustability is 5" from 15"H to 20"H and is standard on work chairs. A 7" range of adjustability (15³/₄"H to 22¹/₄"H) is available as an option. An 8" range of adjustability (22"H to 30"H) is available on stools.



Seat edge angle adjusts by pulling handle up and shifting your weight forward to front edge of seat to alter front edge by close to 2". Release handle to lock. This feature is standard on work chairs and stools.

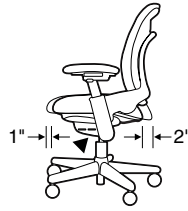

Seat depth adjusts 3" (15¹/₄"–18¹/₄") by pulling handle up. Slide seat forward or back to accommodate various leg lengths. Release handle to lock. This feature is standard on work chairs and stools. Stools and armless chairs adjust 2¹/₄" (15¹/₄"–17¹/₂").

Back Adjustments

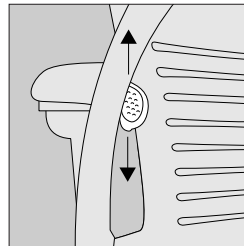

Lumbar height adjusts 5" (5¹/₄" to 10¹/₄" from seat) by grabbing exposed tabs and sliding the lumbar support up or down. This 5" range feature is available as an option on work chairs and stools with standard upholstery only.

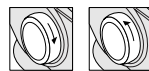
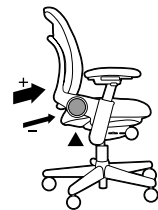

Lower back firmness adjusts by turning knob two complete turns. Forward increases firmness. Backward decreases firmness. This feature is standard on work chairs and stools.

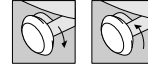

Upper back force adjusts by turning knob five complete turns. Turn knob forward to increase rate of tension; backward to decrease. This feature is standard on work chairs and stools.

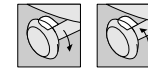
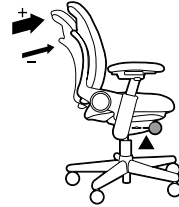

Variable back stop. Rotate handle up or down to set recline angle. Lean back to desired back angle. Five stops are available. This feature is standard on work chairs and stools. *Tip: To stop in upright position, remove weight from back and rotate lever up.*

Arm Adjustments

Soft urethane, see-through, height-, width-, and pivot-adjustable arms come standard on HD work chairs and stools. Work chairs and stools without arms are available as an option.



Arm height adjusts independently within a range of 4" (7"–11" from the seat). Push button on outside and under arm cap in while moving arms up or down. Releasing buttons locks arms in position.

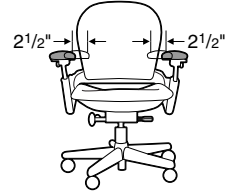

Arm width adjusts 2¹/₂" each independently.

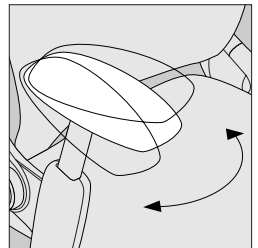

Arms pivot 12° in and 21° out independently. Grasp arm and push front to left or right. Range is 12¹/₂" to 19³/₄" between arms.

Arm packages available for easy retrofit can be ordered from Customer Service Parts.

Other Features

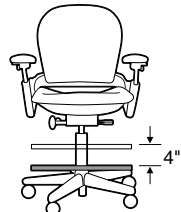

Foot ring height on stools adjusts by first lifting ring and rotating it counter-clockwise to unlock it. Then raise or lower ring up to 4" to desired position before rotating it clockwise to lock it.

Soft-wheel casters for hard floors are available for specific applications.

Surface Materials

▶ See surface materials on page 282 for specific availability or refer to the *Surface Materials Reference Manual* for further information.

Upholstery

- Fabric
- Fabric with soil-retardant treatment (option)
- Leather

Hard components

(base, outer back, outer seat, and foot ring on stools)

- 6205 Black
- 6296 Sterling

Arms

- Soft urethane caps: 6205 Black only

Vest

- 5056 Black

All Steelcase seating with standard upholstery fabrics

complies with requirements of the BIFMA First Generation Voluntary Upholstered Furniture Flammability Standard, as well as the State of California Technical Bulletin 117. All standard seating is labeled to be in compliance with California TB117.

Programs & Services

▶ See the *Surface Materials Reference Manual* for further detail about programs and services offered for seating.

The Customer's Own Material (COM) Program

offers the opportunity for customers to select fabrics that are not offered through the standard Steelcase surface materials program for use on Steelcase products. Through the COM program, Steelcase will test your materials for application on Steelcase products. Once approved, you can place your order. Steelcase will facilitate the entire ordering process and give you a production schedule. Steelcase will order the COM fabric directly from the textile manufacturer. For up-to-date information regarding fabric test results for all COM fabrics and details regarding yardage requirements for most Seating lines, visit the COM Web site:

- Visit www.steelcase.com
- Click on "Services"
- Select "Steelcase COM (Customer's Own Materials)" from the pull-down menu
- Click on the "Go" button

Soil retardants are treatments that provide long-term soil and stain resistance to a fabric without affecting the shade or the integrity of the fabric. The following Steelcase Textiles are available pre-treated with soil retardant. (You do not need to select the soil-retardant option for these fabrics and incur the \$17 upcharge.)

- Canzoné
- Cavalcade
- Jacks
- Link
- Regis
- Rook
- Roulette
- Skittles
- Spyder
- Sweepstakes

Soil-retardant treatment is available on all other seating fabrics at an additional \$17 U.S. per seating unit. To order this option, please select "Soil-Retardant Treatment" under "Optional Accessories."

For soil-retardant treatment on COMs, please select "Soil-Retardant Treatment" under "Optional Accessories." Minimums or additional yardage may be required. Please contact the vendor directly for specific information.

Extended lead times may be necessary for this service.

Contact your Steelcase Sales Service representative or contact Line 1 at 1.888.STEELCASE (1.888.783.3522).

Fire Codes

▶ See pages 289–290 for upholstery fabrics available for use with FCS modification.

Steelcase offers Fire Code Seating modification (FCS) on nearly all seating models. The most rigorous fire codes in the nation have been developed in California, and the Steelcase FCS modification is designed to meet those codes. Fire Code Seating (FCS) indicates that a product is constructed to meet the strict fire code requirements of high public occupancy areas such as theaters, meeting rooms, and lobbies. The FCS standards will meet both the State of California Home Furnishing Technical Bulletin 133 (Cal TB 133) and Boston Fire Code (BFC). Boston adopted the California Home Furnishing Technical Bulletin TB 133 test standard in 1992.

Local codes may have special requirements for upholstery.

Dimensions

▶ Page 198

Shipping

Leap HD chairs are shipped cartoned. Uncartoned chairs are not available.

Resources

Printed Materials

- ▶ Leap Brochure (03-0003669)
- ▶ Why Leap (S11014)
- ▶ Leap Overview Positioning Piece (S11016)
- ▶ Leap White Paper Packets (S11019)
- ▶ Leap Work Effectiveness Study White Papers (02-0001642)
- ▶ Leap Quick Reference Pocket Card (S11042)
- ▶ Leap User Guide (S11236)
- ▶ Seating Overview (03-0003368)

Computer Tools

- ▶ Interactive User Guide available on www.steelcase.com
- ▶ Electronic User Disk (S2305)—Windows
- ▶ Leap CD-ROM (S11015)

Applications

Standard Upholstery

- ▶ Page 16

Pillowed Upholstery

- ▶ Page 17

Bare-Back

- ▶ Page 18

Dimensions

Leap 462 Series High Density

• Features	• Overall Depth	Width	Height	• Seat Depth	• Functional Seat Depth (with Arms)	• Seat Width	• Seat Height from Floor	• Back Width	• Back Height from Seat	• Back Lumbar Height
Leap 462 Series High Density Work Chairs										
Adjustable Seat Depth	21¾" to 24¾"	25½"	38½" to 44½"	19"	15¼" to 18¼"	19"	15" to 20"	18"	24½"	5¼" to 10¼"
Fixed Seat Depth	23¾"	25½"	38½" to 44½"	19"	16¼"	19"	15" to 20"	18"	24½"	5¼" to 10¼"
Leap 462 Series Full-Back Work Chairs for Comparison										
Adjustable Seat Depth	21¾" to 24¾"	29¼"	37" to 43"	19"	15¼" to 18¼"	20"	15" to 20"	19"	23"	5¼" to 10¼"
Fixed Seat Depth	23¾"	29¼"	37" to 43"	19"	16¼"	20"	15" to 20"	19"	23"	5¼" to 10¼"
Leap 462 Series High Density Stools										
Adjustable Seat Depth	21¾" to 24"	25½"	43½" to 51½"	19"	15¼" to 17½"	19"	22" to 30"	18"	24½"	5¼" to 10¼"
Fixed Seat Depth	23¾"	25½"	43½" to 51½"	19"	16¼"	19"	22" to 30"	18"	24½"	5¼" to 10¼"
Leap 462 Series Full-Back Stools for Comparison										
Adjustable Seat Depth	21¾" to 24"	29¼"	42" to 50"	19"	15¼" to 17½"	20"	22" to 30"	19"	23"	5¼" to 10¼"
Fixed Seat Depth	23¾"	29¼"	42" to 50"	19"	16¼"	20"	22" to 30"	19"	23"	5¼" to 10¼"

Functional seat depth measurements were taken with Leap's Live Back unflexed. If fully flexed, the functional seat depth measurements on the adjustable seat depth models are 14½"–19" and 16¼"–17¼" on the fixed seat depth models.

Dimensions were measured with BIFMA CMD.

Seat depth measurement is simply the size of the seat from front to back.

Chairs without the seat edge angle adjustment have a flexing front seat edge of approximately ½".

Chairs with the seat edge angle adjustment allow the front edge of the seat to drop approximately 2".

Arm width adjustment is 12½"–19¼".

Lumbar Flex Zone	Width Between Arms	Arm to Floor	Arm Height from Seat	Arm Cap Pivot Range	Seat Pan Angle	Angle Between Seat and Back
5 1/4" to 10 1/4"	12 1/2" to 19 3/4"	22" to 32"	7" to 11"	33°	-6° to 3°	99° to 118°
5 1/4" to 10 1/4"	12 1/2" to 19 3/4"	22" to 32"	7" to 11"	33°	0° to 3°	99° to 118°
5 1/4" to 10 1/4"	12 1/4" to 21"	22" to 32"	7" to 11"	35°	-6° to 3°	99° to 118°
5 1/4" to 10 1/4"	12 1/4" to 21"	22" to 32"	7" to 11"	35°	0° to 3°	99° to 118°
5 1/4" to 10 1/4"	12 1/2" to 19 3/4"	28" to 40"	7" to 11"	33°	-6° to 3°	99° to 118°
5 1/4" to 10 1/4"	12 1/2" to 19 3/4"	28" to 40"	7" to 11"	33°	0° to 3°	99° to 118°
5 1/4" to 10 1/4"	12 1/4" to 21"	28" to 40"	7" to 11"	35°	-6° to 3°	99° to 118°
5 1/4" to 10 1/4"	12 1/4" to 21"	28" to 40"	7" to 11"	35°	0° to 3°	99° to 118°

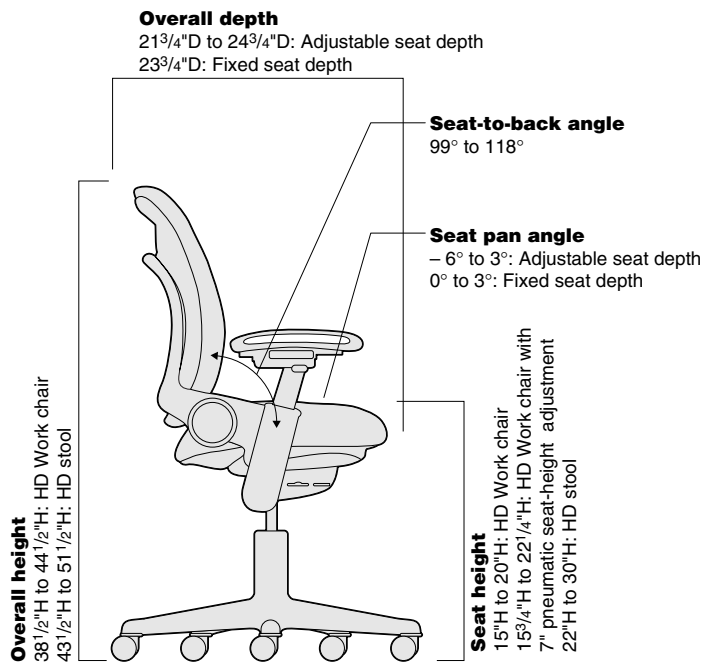
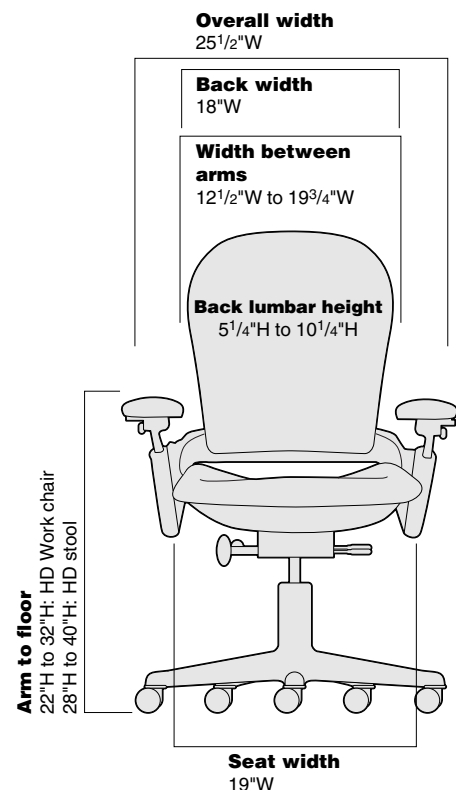

Leap 462 Series High Density Work Chairs

Ribbon Backframe

Standard Upholstery on Back and Seat



Standard Includes		Required to Specify
<ul style="list-style-type: none"> ▶ Need help? Product details, page 194 	<ul style="list-style-type: none"> • Upper back force • 5" pneumatic seat-height adjustment • Variable back stop • Lower back firmness • Flexing front edge seat • High density see-through independent height-, width-, and pivot-adjustable arms and soft urethane arm caps: black • Frame, seat shell, outer back, and five-arm base: plastic • Adjustable seat: 3" seat depth adjustment and seat edge angle adjustment • Standard upholstery design: fabric price group 1 • 3"-diameter, hard-composition, dual-wheel casters: black 	<ol style="list-style-type: none"> 1 Style number 2 Plastic color for frame, seat shell, outer back, and base 3 Fabric color number for upholstery on seat 4 Options, if selected (see below) <ul style="list-style-type: none"> ▶ See <i>Surface Materials</i>, page 282.

	Options	U.S. Price	Required to Specify
Surface Materials	Upholstery		
	• Fabric price group 1	No cost	Specify fabric color number.
	• Fabric price group 2	+\$ 20	Specify fabric color number.
	• Fabric price group 3	+\$ 40	Specify fabric color number.
	• Fabric price group 4	+\$ 55	Specify fabric color number.
	• Fabric price group 5	+\$ 70	Specify fabric color number.
	• Fabric price group 6	+\$ 85	Specify fabric color number.
	• Fabric price group 7	+\$100	Specify fabric color number.
	• Fabric price group 8	+\$125	Specify fabric color number.
	• Fabric price group 9	+\$155	Specify fabric color number.
• Fabric price group 10	+\$175	Specify fabric color number.	
• Customer's Own Material (COM) or Designtex Graded-In	+\$ 30	Add suffix X to the style number.	
• Steelcase leather upholstery	+\$590	▶ See <i>Surface Materials Reference Manual</i> . Add suffix S to the style number and specify leather color number.	
• Steelcase vinyl	+\$299	Add suffix S to the style number and specify vinyl color number.	
• Customer's Own Leather (COL)	+\$299	Add suffix S to the style number and specify leather color number.	
• Fire Code Seating (FCS)	+\$ 50	▶ See <i>Surface Materials Reference Manual</i> . Add suffix F to the style number.	
• Soil-retardant treatment applied to upholstery fabric	+\$ 17	Specify <i>with soil-retardant treatment</i> .	
Stitched Edge Detail	• Steelcase Classics Collection fabrics with stitched edge detail on back only	+\$ 30	Add suffix X to the style number.
Armless	• Without arms	-\$225	Specify <i>without arms</i> .
Seat Height	• 7" pneumatic seat-height adjustment	+\$ 35	Specify <i>with 7" pneumatic seat-height adjustment</i> .
Seat Depth	• With 3" seat depth adjustment only	-\$ 50	Specify <i>with seat depth adjustment only</i> .
Fixed Seat	• Without adjustable seat (no seat depth or seat edge angle)	-\$150	Specify <i>with fixed seat</i> .
Lumbar Height	• 5" travel for additional lumbar support	+\$ 50	Specify <i>with adjustable lumbar height</i> .
Casters	• Soft, dual-wheel casters for use on hard floors	+\$ 18	Specify <i>with soft casters</i> .

Tip: Use an **X** suffix when specifying COM or Designtex Graded-In. There is a \$30 U.S. upcharge plus the cost of the fabric price group selected.

Tip: Always add suffixes in alphabetical order when specifying options to Leap seating.

Tip: Fire Code Seating (FCS) option is available with certain upholstery fabric choices only. ▶ Pages 289–290

▶ Detailed dimensions, page 198



For Canadian Pricing
Multiply U.S. Price by 1.38.
▶ See page 1 for details.

Specification Information

HD Back
with Height-, Width-, and Pivot-
Adjustable Arms



• Style • Number	• U.S. • Base • Price
---------------------	-----------------------------

With Adjustable Seat (Seat Depth and Seat Edge Angle)

462LEAPHD1	\$1138
•	•



For Canadian Pricing
Multiply U.S. Price by 1.38.
▶ See page 1 for details.

Leap 462 Series High Density Work Chairs

Ribbon Backframe

Pillowed Upholstery on Back and Seat



	Standard Includes	Required to Specify
▶ Need help? Product details, page 194	<ul style="list-style-type: none"> • Upper back force • 5" pneumatic seat-height adjustment • Variable back stop • Lower back firmness • Flexing front edge seat • High density see-through independent height-, width-, and pivot-adjustable arms and soft urethane arm caps: black • Frame, seat shell, outer back, and five-arm base: plastic • Adjustable seat: 3" seat depth adjustment and seat edge angle adjustment • Pillowed upholstery design: fabric price group 1 • Performance fabric to secure back and seat pillows • 3"-diameter, hard-composition, dual-wheel casters: black 	<ol style="list-style-type: none"> 1 Style number 2 Plastic color for frame, seat shell, outer back, and base 3 Fabric color number for upholstery on seat and back 4 Options, if selected (see below) <ul style="list-style-type: none"> ▶ See <i>Surface Materials</i>, page 282.

	Options	U.S. Price	Required to Specify
Surface Materials	Upholstery		
	• Fabric price group 1	No cost	Specify fabric color number.
	• Fabric price group 2	+\$ 20	Specify fabric color number.
	• Fabric price group 3	+\$ 40	Specify fabric color number.
	• Fabric price group 4	+\$ 55	Specify fabric color number.
	• Fabric price group 5	+\$ 70	Specify fabric color number.
	• Fabric price group 6	+\$ 85	Specify fabric color number.
	• Fabric price group 7	+\$100	Specify fabric color number.
	• Fabric price group 8	+\$125	Specify fabric color number.
	• Fabric price group 9	+\$155	Specify fabric color number.
• Fabric price group 10	+\$175	Specify fabric color number.	
• Customer's Own Material (COM)	+\$ 30	▶ See <i>Surface Materials Reference Manual</i> to specify.	
	• Steelcase leather upholstery	+\$250	Add suffix S to the style number and specify leather color number.
	• Steelcase vinyl	No cost	Add suffix S to the style number and specify vinyl color number.
	• Customer's Own Leather (COL)	+\$100	Add suffix S to the style number and specify leather color number.
	• Fire Code Seating (FCS)	+\$ 50	▶ See <i>Surface Materials Reference Manual</i> . Add suffix F to the style number.
	• Soil-retardant treatment applied to upholstery fabric	+\$ 17	Specify <i>with soil-retardant treatment</i> .
Armless	• Without arms	-\$225	Specify <i>without arms</i> .
Seat Height	• 7" pneumatic seat-height adjustment	+\$ 35	Specify <i>with 7" pneumatic seat-height adjustment</i> .
Seat Depth	• With 3" seat depth adjustment only	-\$ 50	Specify <i>with seat depth adjustment only</i> .
Fixed Seat	• Without adjustable seat (no seat depth or seat edge angle)	-\$150	Specify <i>with fixed seat</i> .
Casters	• Soft, dual-wheel casters for use on hard floors	+\$ 18	Specify <i>with soft casters</i> .

Tip: Always add suffixes in alphabetical order when specifying options to Leap seating.

Tip: Fire Code Seating (FCS) option is available with certain upholstery fabric choices only.
▶ Pages 289–290

▶ Detailed dimensions, page 198



For Canadian Pricing
Multiply U.S. Price by 1.38.
▶ See page 1 for details.

Specification Information

HD Back
with Height-, Width-, and Pivot-
Adjustable Arms



• Style Number	• U.S. Base Price
-------------------	-------------------------

With Adjustable Seat (Seat Depth and Seat Edge Angle)

462LEAPHD2	\$1238
------------	--------



For Canadian Pricing
Multiply U.S. Price by 1.38.
▶ See page 1 for details.

Leap 462 Series High Density Work Chairs

Ribbon Backframe

Bare-Back and Standard Upholstery on Seat



	Standard Includes	Required to Specify
▶ Need help? Product details, page 194	<ul style="list-style-type: none"> • Upper back force • 5" pneumatic seat-height adjustment • Variable back stop • Lower back firmness • Flexing front edge seat • High density see-through independent height-, width-, and pivot-adjustable arms and soft urethane arm caps: black • Frame, seat shell, back, and five-arm base: plastic • Adjustable seat: 3" seat depth adjustment and seat edge angle adjustment • Standard upholstery design on seat: fabric price group 1 • 3"-diameter, hard-composition, dual-wheel casters: black 	<ol style="list-style-type: none"> 1 Style number 2 Plastic color for frame, seat shell, back, and base 3 Fabric color number for upholstery on seat 4 Options, if selected (see below) <ul style="list-style-type: none"> ▶ See <i>Surface Materials</i>, page 282.

	Options	U.S. Price	Required to Specify
Surface Materials	Upholstery <ul style="list-style-type: none"> • Fabric price group 1 • Fabric price group 2 • Fabric price group 3 • Fabric price group 4 • Fabric price group 5 • Fabric price group 6 • Fabric price group 7 • Fabric price group 8 • Fabric price group 9 • Fabric price group 10 • Customer's Own Material (COM) • Steelcase leather upholstery • Steelcase vinyl • Customer's Own Leather (COL) • Soil-retardant treatment applied to upholstery fabric 	<ul style="list-style-type: none"> No cost +\$ 10 +\$ 20 +\$ 28 +\$ 35 +\$ 43 +\$ 50 +\$ 63 +\$ 78 +\$ 88 +\$ 15 +\$300 +\$155 +\$155 +\$ 17 	<ul style="list-style-type: none"> Specify fabric color number. Specify fabric color number. Specify fabric color number. Specify fabric color number. Specify fabric color number. Specify fabric color number. Specify fabric color number. Specify fabric color number. Specify fabric color number. Specify fabric color number. ▶ See <i>Surface Materials Reference Manual</i> to specify. Add suffix S to the style number and specify leather color number. Add suffix S to the style number and specify vinyl color number. Add suffix S to the style number and specify leather color number. ▶ See <i>Surface Materials Reference Manual</i>. Specify with soil-retardant treatment.
Armless	<ul style="list-style-type: none"> • Without arms 	-\$225	Specify <i>without arms</i> .
Seat Height	<ul style="list-style-type: none"> • 7" pneumatic seat-height adjustment 	+\$ 35	Specify with <i>7" pneumatic seat-height adjustment</i> .
Seat Depth	<ul style="list-style-type: none"> • With 3" seat depth adjustment only 	-\$ 50	Specify with <i>seat depth adjustment only</i> .
Fixed Seat	<ul style="list-style-type: none"> • Without adjustable seat (no seat depth or seat edge angle) 	-\$150	Specify with <i>fixed seat</i> .
Casters	<ul style="list-style-type: none"> • Soft, dual-wheel casters for use on hard floors 	+\$ 18	Specify with <i>soft casters</i> .
Vest	<ul style="list-style-type: none"> • Vest for use on bare-back: 5056 Black only 	+\$ 40	Specify with <i>vest</i> .

Tip: Always add suffixes in alphabetical order when specifying options to Leap seating.

▶ Detailed dimensions, page 198



For Canadian Pricing
Multiply U.S. Price by 1.38.
▶ See page 1 for details.

Specification Information

HD Back
with Height-, Width-, and Pivot-
Adjustable Arms



Style Number	U.S. Base Price
-----------------	-----------------------

With Adjustable Seat (Seat Depth and Seat Edge Angle)

462LEAPHD3	\$1138
------------	--------



For Canadian Pricing
Multiply U.S. Price by 1.38.
▶ See page 1 for details.

Leap 462 Series High Density Work Chairs

Ribbon Backframe

Bare-Back and Pillowed Upholstery on Seat



	Standard Includes	Required to Specify
▶ Need help? Product details, page 194	<ul style="list-style-type: none"> • Upper back force • 5" pneumatic seat-height adjustment • Variable back stop • Lower back firmness • Flexing front edge seat • High density see-through independent height-, width-, and pivot-adjustable arms and soft urethane arm caps: black • Frame, seat shell, back, and five-arm base: plastic • Adjustable seat: 3" seat depth adjustment and seat edge angle adjustment • Pillowed upholstery design on seat: fabric price group 1 • Performance fabric to secure seat pillow • 3"-diameter, hard-composition, dual-wheel casters: black 	<ol style="list-style-type: none"> 1 Style number 2 Plastic color for frame, seat shell, back, and base 3 Fabric color number for upholstery on seat 4 Options, if selected (see below) ▶ See <i>Surface Materials</i>, page 282.

	Options	U.S. Price	Required to Specify
Surface Materials	Upholstery <ul style="list-style-type: none"> • Fabric price group 1 • Fabric price group 2 • Fabric price group 3 • Fabric price group 4 • Fabric price group 5 • Fabric price group 6 • Fabric price group 7 • Fabric price group 8 • Fabric price group 9 • Fabric price group 10 • Customer's Own Material (COM) <ul style="list-style-type: none"> • Steelcase leather upholstery • Steelcase vinyl • Customer's Own Leather (COL) • Soil-retardant treatment applied to upholstery fabric 	<ul style="list-style-type: none"> No cost +\$ 10 +\$ 20 +\$ 28 +\$ 35 +\$ 43 +\$ 50 +\$ 63 +\$ 78 +\$ 88 +\$ 15 +\$125 No cost +\$ 50 +\$ 17 	<ul style="list-style-type: none"> Specify fabric color number. Specify fabric color number. Specify fabric color number. Specify fabric color number. Specify fabric color number. Specify fabric color number. Specify fabric color number. Specify fabric color number. Specify fabric color number. Specify fabric color number. ▶ See <i>Surface Materials Reference Manual</i> to specify. Add suffix S to the style number and specify leather color number. Add suffix S to the style number and specify vinyl color number. Add suffix S to the style number and specify leather color number. ▶ See <i>Surface Materials Reference Manual</i>. Specify <i>with soil-retardant treatment</i>.
Armless	<ul style="list-style-type: none"> • Without arms 	-\$225	Specify <i>without arms</i> .
Seat Height	<ul style="list-style-type: none"> • 7" pneumatic seat-height adjustment 	+\$ 35	Specify <i>with 7" pneumatic seat-height adjustment</i> .
Seat Depth	<ul style="list-style-type: none"> • With 3" seat depth adjustment only 	-\$ 50	Specify <i>with seat depth adjustment only</i> .
Fixed Seat	<ul style="list-style-type: none"> • Without adjustable seat (no seat depth or seat edge angle) 	-\$150	Specify <i>with fixed seat</i> .
Casters	<ul style="list-style-type: none"> • Soft, dual-wheel casters for use on hard floors 	+\$ 18	Specify <i>with soft casters</i> .
Vest	<ul style="list-style-type: none"> • Vest for use on bare-back: 5056 Black only 	+\$ 40	Specify <i>with vest</i> .

Tip: Always add suffixes in alphabetical order when specifying options to Leap seating.

▶ Detailed dimensions, page 198



For Canadian Pricing
Multiply U.S. Price by 1.38.
▶ See page 1 for details.

Specification Information

HD Back
with Height-, Width-, and Pivot-
Adjustable Arms



• Style • Number	• U.S. • Base • Price

With Adjustable Seat (Seat Depth and Seat Edge Angle)

462LEAPHD4	\$1188



For Canadian Pricing
Multiply U.S. Price by 1.38.
▶ See page 1 for details.

Leap 462 Series High Density Stools

Ribbon Backframe

Standard Upholstery on Back and Seat



Standard Includes	Required to Specify
<ul style="list-style-type: none"> ▶ Need help? Product details, page 194 • Upper back force • 8" pneumatic seat-height adjustment • Variable back stop • Lower back firmness • Flexing front edge seat • High density see-through independent height-, width-, and pivot-adjustable arms and soft urethane arm caps: black • Frame, seat shell, outer back, and five-arm base: plastic • Adjustable foot ring 4" • Adjustable seat: 2¼" seat depth adjustment and seat edge angle adjustment • Standard upholstery design: fabric price group 1 • 2"-diameter, hard-composition, dual-wheel casters: black 	<ol style="list-style-type: none"> 1 Style number 2 Plastic color for frame, seat shell, outer back, and base 3 Fabric color number for upholstery on seat and back 4 Options, if selected (see below) <ul style="list-style-type: none"> ▶ See <i>Surface Materials</i>, page 282.

Options	U.S. Price	Required to Specify
Surface Materials Upholstery <ul style="list-style-type: none"> • Fabric price group 1 • Fabric price group 2 • Fabric price group 3 • Fabric price group 4 • Fabric price group 5 • Fabric price group 6 • Fabric price group 7 • Fabric price group 8 • Fabric price group 9 • Fabric price group 10 • Customer's Own Material (COM) or Designtex Graded-In • Steelcase leather upholstery • Steelcase vinyl • Customer's Own Leather (COL) • Fire Code Seating (FCS) • Soil-retardant treatment applied to upholstery fabric 	<ul style="list-style-type: none"> No cost +\$ 20 +\$ 40 +\$ 55 +\$ 70 +\$ 85 +\$100 +\$125 +\$155 +\$175 +\$ 30 +\$590 +\$299 +\$299 +\$ 50 +\$ 17 	<ul style="list-style-type: none"> Specify fabric color number. Specify fabric color number. Specify fabric color number. Specify fabric color number. Specify fabric color number. Specify fabric color number. Specify fabric color number. Specify fabric color number. Specify fabric color number. Specify fabric color number. Specify fabric color number. Add suffix X to the style number. ▶ See <i>Surface Materials Reference Manual</i>. Add suffix S to the style number and specify leather color number. Add suffix S to the style number and specify vinyl color number. Add suffix S to the style number and specify leather color number. ▶ See <i>Surface Materials Reference Manual</i>. Add suffix F to the style number. Specify <i>with soil-retardant treatment</i>. Add suffix X to the style number. Specify <i>without arms</i>. Specify <i>with fixed seat</i>. Specify <i>with seat depth adjustment only</i>. Specify <i>with adjustable lumbar height</i>. Specify <i>with soft casters</i>.
Stitched Edge Detail <ul style="list-style-type: none"> • Steelcase Classics Collection fabrics with stitched edge detail on back only 	<ul style="list-style-type: none"> +\$ 30 	<ul style="list-style-type: none"> Add suffix X to the style number.
Armless <ul style="list-style-type: none"> • Without arms 	<ul style="list-style-type: none"> -\$225 	<ul style="list-style-type: none"> Specify <i>without arms</i>.
Fixed Seat <ul style="list-style-type: none"> • Without adjustable seat (no seat depth or seat edge angle) 	<ul style="list-style-type: none"> -\$150 	<ul style="list-style-type: none"> Specify <i>with fixed seat</i>.
Seat Depth <ul style="list-style-type: none"> • With 2¼" seat depth adjustment only 	<ul style="list-style-type: none"> -\$ 50 	<ul style="list-style-type: none"> Specify <i>with seat depth adjustment only</i>.
Lumbar Height <ul style="list-style-type: none"> • 5" travel for additional lumbar support 	<ul style="list-style-type: none"> +\$ 50 	<ul style="list-style-type: none"> Specify <i>with adjustable lumbar height</i>.
Casters <ul style="list-style-type: none"> • Soft, dual-wheel casters for use on hard floors 	<ul style="list-style-type: none"> +\$ 18 	<ul style="list-style-type: none"> Specify <i>with soft casters</i>.

Tip: Use an **X** suffix when specifying COM or Designtex Graded-In. There is a \$30 U.S. upcharge plus the cost of the fabric price group selected.

Tip: Always add suffixes in alphabetical order when specifying options to Leap seating.

Tip: Fire Code Seating (FCS) option is available with certain upholstery fabric choices only.
▶ Pages 289–290

▶ Detailed dimensions, page 198



For Canadian Pricing
Multiply U.S. Price by 1.38.
▶ See page 1 for details.

Specification Information

HD Back
with Height-, Width-, and Pivot-
Adjustable Arms



• Style • Number	• U.S. • Base • Price
•	•
•	•
•	•

With Adjustable Seat (Seat Depth and Seat Edge Angle)

462STLHD1	\$1325
•	•
•	•



For Canadian Pricing
Multiply U.S. Price by 1.38.
▶ See page 1 for details.

Specification Information

HD Back
with Height-, Width-, and Pivot-
Adjustable Arms



• Style	• U.S.
• Number	• Base
•	• Price
•	•
•	•

With Adjustable Seat (Seat Depth and Seat Edge Angle)

462STLHD2	\$1425
•	•
•	•



For Canadian Pricing
Multiply U.S. Price by 1.38.
▶ See page 1 for details.

Leap 462 Series High Density Stools

Ribbon Backframe

Bare-Back and Standard Upholstery on Seat



	Standard Includes	Required to Specify
▶ Need help? Product details, page 194	<ul style="list-style-type: none"> • Upper back force • 8" pneumatic seat-height adjustment • Variable back stop • Lower back firmness • Flexing front edge seat • High density see-through independent height-, width-, and pivot-adjustable arms and soft urethane arm caps: black • Frame, seat shell, back, and five-arm base: plastic • Adjustable foot ring 4" • Adjustable seat: 2¼" seat depth adjustment and seat edge angle adjustment • Standard upholstery design on seat: fabric price group 1 • 2"-diameter, hard-composition, dual-wheel casters: black 	<ol style="list-style-type: none"> 1 Style number 2 Plastic color for frame, seat shell, back, and base 3 Fabric color number for upholstery on seat 4 Options, if selected (see below) <ul style="list-style-type: none"> ▶ See <i>Surface Materials</i>, page 282.

	Options	U.S. Price	Required to Specify
Surface Materials	Upholstery <ul style="list-style-type: none"> • Fabric price group 1 • Fabric price group 2 • Fabric price group 3 • Fabric price group 4 • Fabric price group 5 • Fabric price group 6 • Fabric price group 7 • Fabric price group 8 • Fabric price group 9 • Fabric price group 10 • Customer's Own Material (COM) <ul style="list-style-type: none"> • Steelcase leather upholstery • Steelcase vinyl • Customer's Own Leather (COL) <ul style="list-style-type: none"> • Soil-retardant treatment applied to upholstery fabric 	<ul style="list-style-type: none"> No cost +\$ 10 +\$ 20 +\$ 28 +\$ 35 +\$ 43 +\$ 50 +\$ 63 +\$ 78 +\$ 88 +\$ 15 <ul style="list-style-type: none"> +\$300 +\$155 +\$155 <ul style="list-style-type: none"> +\$ 17 	<ul style="list-style-type: none"> Specify fabric color number. Specify fabric color number. Specify fabric color number. Specify fabric color number. Specify fabric color number. Specify fabric color number. Specify fabric color number. Specify fabric color number. Specify fabric color number. Specify fabric color number. ▶ See <i>Surface Materials Reference Manual</i> to specify. Add suffix S to the style number and specify leather color number. Add suffix S to the style number and specify vinyl color number. Add suffix S to the style number and specify leather color number. ▶ See <i>Surface Materials Reference Manual</i>. Specify <i>with soil-retardant treatment</i>.
Armless	<ul style="list-style-type: none"> • Without arms 	-\$225	Specify <i>without arms</i> .
Fixed Seat	<ul style="list-style-type: none"> • Without adjustable seat (no seat depth or seat edge angle) 	-\$150	Specify <i>with fixed seat</i> .
Seat Depth	<ul style="list-style-type: none"> • With 2¼" seat depth adjustment only 	-\$ 50	Specify <i>with seat depth adjustment only</i> .
Casters	<ul style="list-style-type: none"> • Soft, dual-wheel casters for use on hard floors 	+\$ 18	Specify <i>with soft casters</i> .
Vest	<ul style="list-style-type: none"> • Vest for use on bare-back: 5056 Black only 	+\$ 40	Specify <i>with vest</i> .

Tip: Always add suffixes in alphabetical order when specifying options to Leap seating.

▶ Detailed dimensions, page 198



For Canadian Pricing
Multiply U.S. Price by 1.38.
▶ See page 1 for details.

Specification Information

HD Back
with Height-, Width-, and Pivot-
Adjustable Arms



• Style • Number	• U.S. • Base • Price
---------------------	-----------------------------

With Adjustable Seat (Seat Depth and Seat Edge Angle)

462STLHD3	\$1325
-----------	--------



For Canadian Pricing
Multiply U.S. Price by 1.38.
▶ See page 1 for details.

Leap 462 Series High Density Stools

Ribbon Backframe

Bare-Back and Pillowed Upholstery on Seat



	Standard Includes	Required to Specify
▶ Need help? Product details, page 194	<ul style="list-style-type: none"> • Upper back force • 8" pneumatic seat-height adjustment • Variable back stop • Lower back firmness • Flexing front edge seat • High density see-through independent height-, width-, and pivot-adjustable arms and soft urethane arm caps: black • Frame, seat shell, back, and five-arm base: plastic • Adjustable foot ring 4" • Adjustable seat: 2 1/4" seat depth adjustment and seat edge angle adjustment • Pillowed upholstery design on seat: fabric price group 1 • Performance fabric to secure seat pillow • 2"-diameter, hard-composition, dual-wheel casters: black 	<ol style="list-style-type: none"> 1 Style number 2 Plastic color for frame, seat shell, back, and base 3 Fabric color number for upholstery on seat 4 Options, if selected (see below) ▶ See <i>Surface Materials</i>, page 282.

	Options	U.S. Price	Required to Specify
Surface Materials	Upholstery <ul style="list-style-type: none"> • Fabric price group 1 • Fabric price group 2 • Fabric price group 3 • Fabric price group 4 • Fabric price group 5 • Fabric price group 6 • Fabric price group 7 • Fabric price group 8 • Fabric price group 9 • Fabric price group 10 • Customer's Own Material (COM) <ul style="list-style-type: none"> • Steelcase leather upholstery • Steelcase vinyl • Customer's Own Leather (COL) <ul style="list-style-type: none"> • Soil-retardant treatment applied to upholstery fabric 	<ul style="list-style-type: none"> No cost +\$ 10 +\$ 20 +\$ 28 +\$ 35 +\$ 43 +\$ 50 +\$ 63 +\$ 78 +\$ 88 +\$ 15 <ul style="list-style-type: none"> +\$125 <ul style="list-style-type: none"> No cost +\$ 50 <ul style="list-style-type: none"> +\$ 17 	<ul style="list-style-type: none"> Specify fabric color number. Specify fabric color number. Specify fabric color number. Specify fabric color number. Specify fabric color number. Specify fabric color number. Specify fabric color number. Specify fabric color number. Specify fabric color number. Specify fabric color number. ▶ See <i>Surface Materials Reference Manual</i> to specify. Add suffix S to the style number and specify leather color number. Add suffix S to the style number and specify vinyl color number. Add suffix S to the style number and specify leather color number. ▶ See <i>Surface Materials Reference Manual</i>. Specify with soil-retardant treatment.
Armless	<ul style="list-style-type: none"> • Without arms 	-\$225	Specify <i>without arms</i> .
Fixed Seat	<ul style="list-style-type: none"> • Without adjustable seat (no seat depth or seat edge angle) 	-\$150	Specify <i>with fixed seat</i> .
Seat Depth	<ul style="list-style-type: none"> • With 2 1/4" seat depth adjustment only 	-\$ 50	Specify <i>with seat depth adjustment only</i> .
Casters	<ul style="list-style-type: none"> • Soft, dual-wheel casters for use on hard floors 	+\$ 18	Specify <i>with soft casters</i> .
Vest	<ul style="list-style-type: none"> • Vest for use on bare-back: 5056 Black only 	+\$ 40	Specify <i>with vest</i> .

Tip: Always add suffixes in alphabetical order when specifying options to Leap seating.

▶ Detailed dimensions, page 198



For Canadian Pricing
Multiply U.S. Price by 1.38.
▶ See page 1 for details.

Specification Information

HD Back
with Height-, Width-, and Pivot-
Adjustable Arms



• Style • Number	• U.S. • Base • Price

With Adjustable Seat (Seat Depth and Seat Edge Angle)

462STLHD4	\$1375



For Canadian Pricing
Multiply U.S. Price by 1.38.
▶ See page 1 for details.

Pillowed Upholstery Packages for Leap HD

Pillow Upholstery Packages for Back and Seat

for Use on Leap HD Ribbon Backframe Chairs with Pillowed Upholstery Option Only

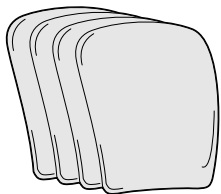

Tip: Pillow packages are sold in quantities of four. To order individual pillows, contact Customer Service Parts.

Tip: Always add suffixes in alphabetical order when specifying options to Leap seating.

Tip: To maintain FCS compliance on Leap chairs, both the original chair and the replacement seat and back cushions must be specified with the FCS option. A Leap FCS chair is identified with an FCS label on the underside of the chair.

Standard Includes	Required to Specify
-------------------	---------------------

- Package of four back and four seat pillows
- Pillowed upholstery design: fabric price group 1
- Performance fabric to secure back and seat

- 1 Style number
 - 2 Fabric color number
 - 3 Plastic color number of chair (determines performance fabric color)
 - 4 Options, if selected (see below)
- ▶ See *Surface Materials*, page 282.

Surface Materials	Options	U.S. Price	Required to Specify
-------------------	---------	------------	---------------------

Surface Materials	• Fabric price group 1	No cost	Specify fabric color number.
	• Fabric price group 2	+\$ 80	Specify fabric color number.
	• Fabric price group 3	+\$ 160	Specify fabric color number.
	• Fabric price group 4	+\$ 220	Specify fabric color number.
	• Fabric price group 5	+\$ 280	Specify fabric color number.
	• Fabric price group 6	+\$ 340	Specify fabric color number.
	• Fabric price group 7	+\$ 400	Specify fabric color number.
	• Fabric price group 8	+\$ 500	Specify fabric color number.
	• Fabric price group 9	+\$ 620	Specify fabric color number.
	• Fabric price group 10	+\$ 700	Specify fabric color number.
• Customer's Own Material (COM)	+\$ 120	▶ See <i>Surface Materials Reference Manual</i> to specify.	
	• Steelcase leather upholstery	+\$1000	Add suffix S to the style number and specify leather color number.
	• Steelcase vinyl	No cost	Add suffix S to the style number and specify vinyl color number.
	• Customer's Own Leather (COL)	+\$ 400	Add suffix S to the style number and specify leather color number.
	• Fire Code Seating (FCS)	+\$ 50	▶ See <i>Surface Materials Reference Manual</i> . Add suffix F to the style number.
	• Soil-retardant treatment	+\$ 68	Specify <i>with soil-retardant treatment</i> .

Specification Information

• Style Number	• U.S. Base Price
•	•
•	•
•	•

Package of 4 Back Pillows and 4 Seat Pillows for HD

HD Back	
462PLWSTHD	\$800
•	•
•	•

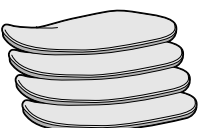
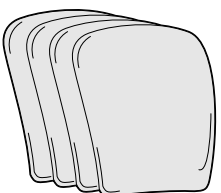

Pillowed Upholstery Packages for Back

for Use on Leap HD Ribbon Backframe Chairs with Pillowed Upholstery Option Only

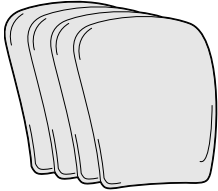

Tip: Pillow packages are sold in quantities of four. To order individual pillows, contact Customer Service Parts.

Tip: Always add suffixes in alphabetical order when specifying options to Leap seating.

Tip: To maintain FCS compliance on Leap chairs, both the original chair and the replacement seat and back cushions must be specified with the FCS option. A Leap FCS chair is identified with an FCS label on the underside of the chair.

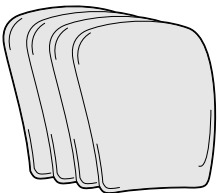

Standard Includes	Required to Specify
-------------------	---------------------

- | | |
|---|---|
| <ul style="list-style-type: none"> • Package of four back pillows • Pillowed upholstery design: fabric price group 1 • Performance fabric to secure back | <ol style="list-style-type: none"> 1 Style number 2 Fabric color number 3 Plastic color number of chair (determines performance fabric color) 4 Options, if selected (see below) <p>▶ See <i>Surface Materials</i>, page 282.</p> |
|---|---|

Surface Materials	Options	U.S. Price	Required to Specify
-------------------	---------	------------	---------------------

Surface Materials	• Fabric price group 1	No cost	Specify fabric color number.
	• Fabric price group 2	+\$ 40	Specify fabric color number.
	• Fabric price group 3	+\$ 80	Specify fabric color number.
	• Fabric price group 4	+\$110	Specify fabric color number.
	• Fabric price group 5	+\$140	Specify fabric color number.
	• Fabric price group 6	+\$170	Specify fabric color number.
	• Fabric price group 7	+\$200	Specify fabric color number.
	• Fabric price group 8	+\$250	Specify fabric color number.
	• Fabric price group 9	+\$310	Specify fabric color number.
	• Fabric price group 10	+\$350	Specify fabric color number.
• Customer's Own Material (COM)	+\$ 60	▶ See <i>Surface Materials Reference Manual</i> to specify.	
	• Steelcase leather upholstery	+\$500	Add suffix S to the style number and specify leather color number.
	• Steelcase vinyl	No cost	Add suffix S to the style number and specify vinyl color number.
	• Customer's Own Leather (COL)	+\$200	Add suffix S to the style number and specify leather color number.
	• Fire Code Seating (FCS)	+\$ 50	▶ See <i>Surface Materials Reference Manual</i> . Add suffix F to the style number.
	• Soil-retardant treatment	+\$ 68	Specify <i>with soil-retardant treatment</i> .

Specification Information

Style Number	U.S. Base Price
.....

Package of 4 Back Pillows for HD

HD Back

462PLWHD	\$400
.....



For Canadian Pricing
Multiply U.S. Price by 1.38.
▶ See page 1 for details.

Pillowed Upholstery Packages for Seat

for Use on Leap HD Ribbon Backframe Chairs with Pillowed Upholstery Option Only

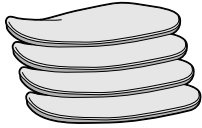

Tip: Pillow packages are sold in quantities of four. To order individual pillows, contact Customer Service Parts.

Tip: Always add suffixes in alphabetical order when specifying options to Leap seating.

Tip: To maintain FCS compliance on Leap chairs, both the original chair and the replacement seat and back cushions must be specified with the FCS option. A Leap FCS chair is identified with an FCS label on the underside of the chair.

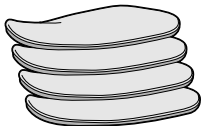

Standard Includes	Required to Specify
-------------------	---------------------

- Package of four seat pillows
- Pillowed upholstery design: fabric price group 1
- Performance fabric to secure seat

- 1 Style number
 - 2 Fabric color number
 - 3 Plastic color number of chair (determines performance fabric color)
 - 4 Options, if selected (see below)
- ▶ See *Surface Materials*, page 282.

Surface Materials	Options	U.S. Price	Required to Specify
-------------------	---------	------------	---------------------

Surface Materials	• Fabric price group 1	No cost	Specify fabric color number.
	• Fabric price group 2	+\$ 40	Specify fabric color number.
	• Fabric price group 3	+\$ 80	Specify fabric color number.
	• Fabric price group 4	+\$110	Specify fabric color number.
	• Fabric price group 5	+\$140	Specify fabric color number.
	• Fabric price group 6	+\$170	Specify fabric color number.
	• Fabric price group 7	+\$200	Specify fabric color number.
	• Fabric price group 8	+\$250	Specify fabric color number.
	• Fabric price group 9	+\$310	Specify fabric color number.
	• Fabric price group 10	+\$350	Specify fabric color number.
	• Customer's Own Material (COM)	+\$ 60	▶ See <i>Surface Materials Reference Manual</i> to specify.
	• Steelcase leather upholstery	+\$500	Add suffix S to the style number and specify leather color number.
	• Steelcase vinyl	No cost	Add suffix S to the style number and specify vinyl color number.
	• Customer's Own Leather (COL)	+\$200	Add suffix S to the style number and specify leather color number.
	• Fire Code Seating (FCS)	+\$ 50	▶ See <i>Surface Materials Reference Manual</i> . Add suffix F to the style number.
	• Soil-retardant treatment	+\$ 68	Specify <i>with soil-retardant treatment</i> .

Specification Information

Style Number	U.S. Base Price

Package of 4 Seat Pillows for HD

462PSTHD	\$400
-----------------	-------



For Canadian Pricing
Multiply U.S. Price by 1.38.
▶ See page 1 for details.

Vest Packages for Bare-Back

for Use on Leap HD Ribbon Backframe Chairs with Pillowed Upholstery Option Only

Vest Packages
for Bare-Back

Leap 462 Series HD

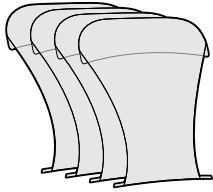

Standard Includes	Required to Specify
<ul style="list-style-type: none"> Package of four vests: 5056 Black only 	Style number

Specification Information

• Style Number	• U.S. Base Price

Package of 4 Vests for HD

HD Back

462VESTHD	\$160



For Canadian Pricing
Multiply U.S. Price by 1.38.
▶ See page 1 for details.



Understanding and Specifying Ally 463 Series Multi-Use Chairs

Understanding Ally 463 Series

Details	222
Dimensions	224

Specifying Ally 463 Series

Sled-Base Multi-Use Chairs	226
----------------------------	-----

Multi-Use Chairs

Multi-use chairs are suitable for use as occasional seating within team spaces, workstations, offices, or wherever extra seating is required.

- Ally 463 Series
- Player 475 Series
- Snodgrass 474 Series

► For additional multi-use chairs, see page 252.

Ally 463 Series Sled-Base Multi-Use Chair

Ally is a multi-use chair with a flexing frame and pivoting back. The chair stacks and offers exceptional comfort for use in side/guest and team applications.

Arms slope downward and will easily clear the front edge of a worksurface or table. The arms are urethane covered.

Steel frame flexes to give added comfort and is available in monochromatic colors.

Plastic glides with a stainless steel insert are standard.

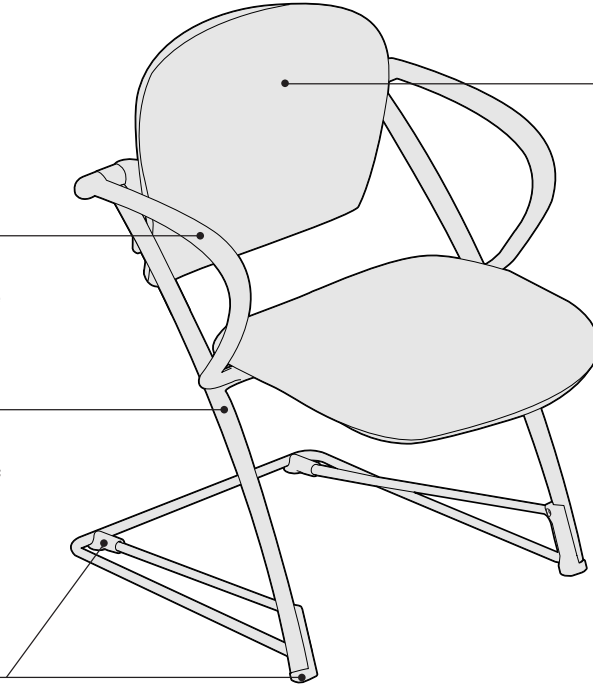

Back pivots for added comfort. Outer back is available in plastic or fully upholstered.

Product Details

Chairs with arms stack three high. Chairs without arms stack four high.

Plastic glides with stainless steel inserts are recommended for carpeted surfaces only.

Soft glides are available for non-carpeted surfaces.

Surface Materials

▶ See surface materials on page 282 for specific availability or refer to the *Surface Materials Reference Manual* for further information.

Upholstery

- Fabric
- Fabric with soil-retardant treatment (option)
- Leather

Frame

- 6205 Black
 - 6259 Midnight
 - 6296 Sterling
- Outer back, arms, and glides will be Black if you select a Black or Sterling frame. These components will be Midnight if you specify a Midnight frame.

Glides

- Stainless steel

All Steelcase seating with standard upholstery fabrics complies with requirements of the BIFMA First Generation Voluntary Upholstered Furniture Flammability Standard, as well as the State of California Technical Bulletin 117. All standard seating is labeled to be in compliance with California TB117.

Programs & Services

▶ See the *Surface Materials Reference Manual* for further detail about programs and services offered for seating.

The Customer's Own Material (COM) Program

offers the opportunity for customers to select fabrics that are not offered through the standard Steelcase surface materials program for use on Steelcase products. Through the COM program, Steelcase will test your materials for application on Steelcase products. Once approved, you can place your order. Steelcase will facilitate the entire ordering process and give you a production schedule. Steelcase will order the COM fabric directly from the textile manufacturer. For up-to-date information regarding fabric test results for all COM fabrics and details regarding yardage requirements for most Seating lines, visit the COM Web site. To locate the COM Web site:

- Visit www.steelcase.com
- Click on "Knowledge & Design"
- Select "Customer's Own Material"

Soil retardants are treatments that provide long-term soil and stain resistance to a fabric without affecting the shade or the integrity of the fabric. The following Steelcase Textiles are available pre-treated with soil retardant. (You do not need to select the soil-retardant option for these fabrics and incur the \$17 upcharge.)

- Canzoné
- Cavalcade
- Jacks
- Link
- Regis
- Rook
- Roulette
- Skittles
- Spyder
- Sweepstakes

Soil-retardant treatment is available on all other seating fabrics at an additional \$17 U.S. per seating unit. To order this option, please select "Soil-Retardant Treatment" under "Optional Accessories."

For soil-retardant treatment on COMs, please select "Soil-Retardant Treatment" under "Optional Accessories." Minimums or additional yardage may be required. Please contact the vendor directly for specific information.

Extended lead times may be necessary for this service.

Contact your Steelcase Sales Service representative at 1.888.STEELCASE (1.888.783.3522).

Fire Codes

▶ See pages 289–290 for upholstery fabrics available for use with FCS modification.

Steelcase offers Fire Code Seating modification (FCS) on nearly all seating models. The most rigorous fire codes in the nation have been developed in California, and the Steelcase FCS modification is designed to meet those codes. Fire Code Seating (FCS) indicates that a product is constructed to meet the strict fire code requirements of high public occupancy areas such as theaters, meeting rooms, and lobbies. The FCS standards will meet both the State of California Home Furnishing Technical Bulletin 133 (Cal TB 133) and Boston Fire Code (BFC). Boston adopted the California Home Furnishing Technical Bulletin TB 133 test standard in 1992.

Local codes may have special requirements for upholstery.

Dimensions

▶ Page 224

Resources

Printed Materials

- ▶ Ally Brochure (S11024)
- ▶ Stackable Seating Brochure (02-0002354)
- ▶ Seating Overview (03-0003368)

Dimensions

Ally 463 Series

Overall Depth	Width	Height	Seat Depth	Functional Seat Depth	Seat Width	Seat Height from Floor	Width Between Arms
Ally 463 Series							
Chair with Arms							
24½"	23¾"	33¾"	20"	17¼"	18⅛"	17¾"	20½"
Chair without Arms							
24½"	21⅛"	33¾"	20"	17¼"	18⅛"	17¾"	20½"

• Back Height from Seat	• Arm Height from Seat	• Arm Height from Floor	• Seat Pan Angle	• Back Width	• Back Lumbar Height	• Angle Between Seat and Back
Chair with Arms						
17½"	9½"	26 ⁵ / ₈ "	3°	18½"	9" to 9¼"	96°
Chair without Arms						
17½"	9½"	26 ⁵ / ₈ "	3°	18½"	9" to 9¼"	96°

Ally 463 Series Sled-Base Multi-Use Chairs



Tip: Always add suffixes in alphabetical order when specifying options to Ally seating.

Tip: Fire Code Seating (FCS) option is available with certain upholstery fabric choices only.
▶ Pages 289–290

Standard Includes		Required to Specify
▶ Need help? Product details, page 222	<ul style="list-style-type: none"> Flexing frame: monochromatic color Pivoting back Upholstery: fabric price group 1 Arms and glides: 6205 Black arms and glides for 6205 Black and 6296 Sterling frames. 6259 Midnight arms and glides for 6259 Midnight frames. 	<ol style="list-style-type: none"> Style number Monochromatic color for frame Fabric color number for upholstery Options, if selected (see below) ▶ See <i>Surface Materials</i> , page 282.

Options	U.S. Price	Required to Specify
Surface Materials	Upholstery <ul style="list-style-type: none"> Fabric price group 1: No cost Fabric price group 2: +\$ 20 Fabric price group 3: +\$ 40 Fabric price group 4: +\$ 55 Fabric price group 5: +\$ 70 Fabric price group 6: +\$100 Fabric price group 7: +\$140 Fabric price group 8: +\$185 Fabric price group 9: +\$220 Fabric price group 10: +\$255 Customer's Own Material (COM): +\$ 30 Steelcase leather upholstery: +\$330 Customer's Own Leather (COL): +\$100 Steelcase vinyl: +\$100 Fire Code Seating (FCS): +\$ 50 Soil-retardant treatment applied to upholstery fabric: +\$ 17 Fully upholstered <ul style="list-style-type: none"> Fabric fully upholstered outer back: +\$ 40 Steelcase leather fully upholstered outer back: +\$435 Customer's Own Leather (COL) fully upholstered outer back: +\$150 	Specify fabric color number. Specify fabric color number. Specify fabric color number. Specify fabric color number. Specify fabric color number. Specify fabric color number. Specify fabric color number. Specify fabric color number. Specify fabric color number. Specify fabric color number. ▶ See <i>Surface Materials Reference Manual</i> to specify. Add suffix S to the style number and specify leather color number. Add suffix S to the style number and specify leather color number. ▶ See <i>Surface Materials Reference Manual</i> to specify. Add suffix S to the style number and specify vinyl color number. Add suffix F to the style number. Specify with soil-retardant treatment. Add suffix U to the style number. Add suffix SU to the style number and specify leather color number. Add suffix SU to the style number. ▶ See <i>Surface Materials Reference Manual</i> to specify.
Glides	<ul style="list-style-type: none"> Soft glides for use on non-carpeted floors: +\$ 5 	Specify with <i>soft glides</i> .

Specification Information

With Arms



• Style Number
• U.S. Base Price

463482 \$410

Without Arms



• Style Number
• U.S. Base Price

463480 \$350

▶ Detailed dimensions, page 224



For Canadian Pricing
Multiply U.S. Price by 1.38.
▶ See page 1 for details.

Understanding and Specifying Player 475 Series Multi-Use Chairs

Understanding Player 475 Series

Details	228
Dimensions	230

Specifying Player 475 Series

Leg-Base Multi-Use Chairs	232
Sled-Base Multi-Use Chairs	236
Leg-Base Stools	240
Accessories	242

Multi-Use Chairs

Multi-use chairs are suitable for use as occasional seating within team spaces, workstations, offices, or wherever extra seating is required.

- Ally 463 Series
- Player 475 Series
- Snodgrass 474 Series

► For additional multi-use chairs, see page 252.

Player 475 Series

Player chairs are guest chairs that also stack. Strength features in the back, arms, and back legs make Player a logical choice for high-traffic areas, and its simple, classic design complements a broad range of work settings.

Arms slope downward and will easily clear the front edge of a worksurface or table. Arms are available in smooth or textured finish.

Steel frame is monochromatic.

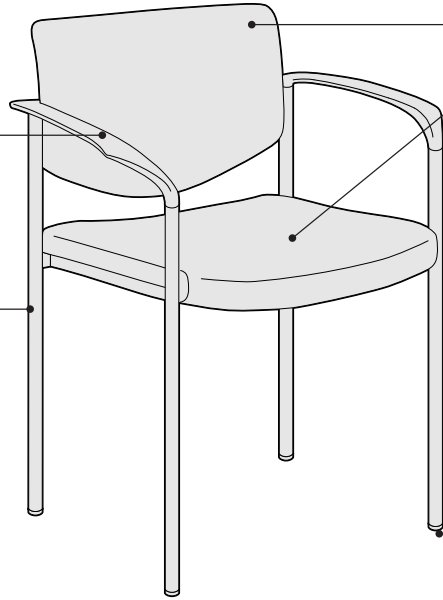

Back and seat, including outer back, are fully upholstered. High-back and thick-seat options are available.

Plastic glides with a stainless steel insert are standard.

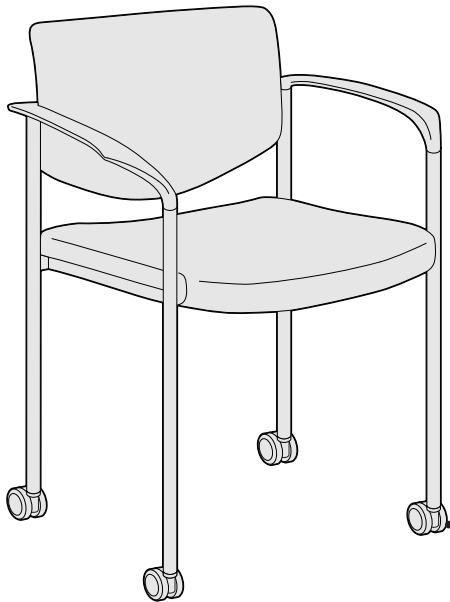

Casters have hard, dual wheels that roll smoothly on carpets. Soft, dual-wheel casters are available for use on hard floor or chair mats. Casters available in black only.

Product Details

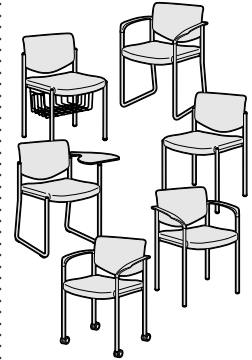

Chair models are available with a leg-base or a sled-base. Stools are available with a leg-base. The leg base arms are available with casters. Chairs and stools are available with several features such as arms, tablet arms, bookrack, high back, and thick seat.

Stackability for leg-base models is six high on the floor and eight high on the transport and storage dolly. Leg-base models with casters are not recommended to stack as damage to arms may occur. Sled-base models, stools, and chairs with tablet arms and bookracks will not stack.

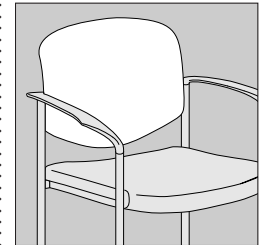

High-back option, available on all Player chairs and stools, adds 3" to back height. Top edge is slightly rounded. Stackability is not affected.

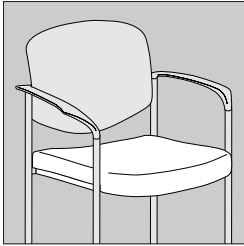

Thick-seat option, available on all Player chairs and stools, increases the thickness of the seat cushion by approximately 1/2". Stackability is not affected.

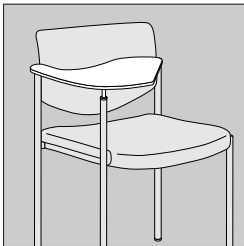

Tablet arm is available right hand and left hand and is shipped knocked down (K.D.). Tablet arm tilts for easy entrance and exit from chair. Tablet arm measures 25 1/2" x 13 1/2". Tablet arm is not available to order separately for installation on existing chairs.

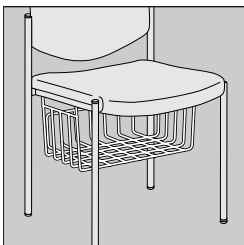

Bookrack is available factory- or field-installed for convenient storage of notebooks and purses. Bookrack measures 10"D x 15 1/2"W x 6"H. Field-installed bookrack will not fit chairs manufactured before January 1, 1994.

Plastic glides, with stainless steel inserts on leg-base Player chairs, are recommended for carpeted surfaces only.

Soft glides are available on Player chairs for non-carpeted surfaces.

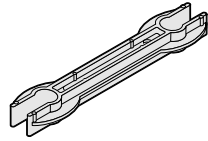

Alignment device is available to temporarily link chairs together for evenly spaced rows. Chairs can be unlinked easily. Spacing between chairs linked with alignment device is 57/8".

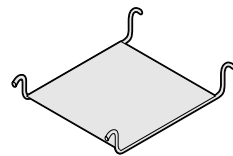

Ganging device is available to link chairs on a more permanent basis. It attaches to the chair's side frame at the same points as a bookrack. Spacing between chairs linked with the ganging device is approximately 9".

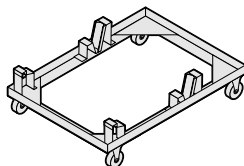

Transport and storage dolly is available to stack, move, and store up to eight chairs with or without arms. Without the dolly, chairs will stack up to six high. Sled-base models, stools, and chairs with tablet arms or bookracks will not stack.

Fully loaded transport dolly measures 32 3/4"D x 25 1/2"W x 55 3/4"H.

Surface Materials

► See surface materials on page 282 for specific availability or refer to the *Surface Materials Reference Manual* for further information.

Upholstery

- Fabric
- Fabric with soil-retardant treatment (option)
- Vinyl

Hard components (arms, frames, and sled base)

- Monochromatic color from list of seating plastic color numbers can be applied to all hard components.

Arms

- Smooth plastic
- Textured plastic

Bookrack

- Paint to match the frame color

Tablet arms

- Laminate

Casters

- Black only

Glides

- Plastic with stainless steel inserts

All Steelcase seating with standard upholstery fabrics complies with requirements of the BIFMA First Generation Voluntary Upholstered Furniture Flammability Standard, as well as the State of California Technical Bulletin 117. All standard seating is labeled to be in compliance with California TB117.

Programs & Services

► See the *Surface Materials Reference Manual* for further detail about programs and services offered for seating.

The Customer's Own Material (COM) Program

offers the opportunity for customers to select fabrics that are not offered through the standard Steelcase surface materials program for use on Steelcase products. Through the COM program, Steelcase will test your materials for application on Steelcase products. Once approved, you can place your order. Steelcase will facilitate the entire ordering process and give you a production schedule. Steelcase will order the COM fabric directly from the textile manufacturer. For up-to-date information regarding fabric test results for all COM fabrics and details regarding yardage requirements for most Seating lines, visit the COM Web site. To locate the COM Web site:

- Visit www.steelcase.com
- Click on "Knowledge & Design"
- Select "Customer's Own Material"

Soil retardants are treatments that provide long-term soil and stain resistance to a fabric without affecting the shade or the integrity of the fabric. The following Steelcase Textiles are available pre-treated with soil retardant. (You do not need to select the soil-retardant option for these fabrics and incur the \$17 upcharge.)

- Canzoné
- Cavalcade
- Jacks
- Link
- Regis
- Rook
- Roulette
- Skittles
- Spyder
- Sweepstakes

Soil-retardant treatment is available on all other seating fabrics at an additional \$17 U.S. per seating unit. To order this option, please select "Soil-Retardant Treatment" under "Optional Accessories."

For soil-retardant treatment on COMs, please select "Soil-Retardant Treatment" under "Optional Accessories." Minimums or additional yardage may be required. Please contact the vendor directly for specific information.

Extended lead times may be necessary for this service.

Contact your Steelcase Sales Service representative at 1.888.STEELCASE (1.888.783.3522).

Fire Codes

► See pages 289–290 for upholstery fabrics available for use with FCS modification.

Steelcase offers Fire Code Seating modification (FCS) on nearly all seating models. The most rigorous fire codes in the nation have been developed in California, and the Steelcase FCS modification is designed to meet those codes. Fire Code Seating (FCS) indicates that a product is constructed to meet the strict fire code requirements of high public occupancy areas such as theaters, meeting rooms, and lobbies. The FCS standards will meet both the State of California Home Furnishing Technical Bulletin 133 (Cal TB 133) and Boston Fire Code (BFC). Boston adopted the California Home Furnishing Technical Bulletin TB 133 test standard in 1992.

Local codes may have special requirements for upholstery.

Dimensions

► Page 230

Resources

Printed Materials

- Player Brochure (S11349)
- Stackable Seating Brochure (02-0002354)
- Seating Overview (03-0003368)

Dimensions

Player 475 Series

Features	Overall Depth	Width	Height	Seat Depth	Functional Seat Depth	Seat Width	Seat Height from Floor	Back Width	Back Height from Seat
Player 475 Series									
Leg-Base Chair with Arms									
	21¼"	25½"	30¼"	19¾"	17½"	18¼"	18¼"	18½"	13¾"
Leg-Base Chair without Arms									
	21¼"	20"	30¼"	19¾"	17½"	18¼"	18¼"	18½"	13¾"
Sled-Base Chair with Arms									
	21¼"	25½"	30¼"	19¾"	17½"	18¼"	18"	18½"	13¾"
Sled-Base Chair without Arms									
	21¼"	20"	30¼"	19¾"	17½"	18¼"	18"	18½"	13¾"
Leg-Base Stool with Arms									
	21¼"	25½"	42"	19¾"	17½"	18¼"	29½"	18½"	13¾"
Leg-Base Stool without Arms									
	21¼"	20"	42"	19¾"	17½"	18¼"	29½"	18½"	13¾"

• Back Lumbar Height	• Width Between Arms	• Arm to Floor	• Arm Height from Seat	• Seat Pan Angle	• Angle Between Seat and Back
----------------------	----------------------	----------------	------------------------	------------------	-------------------------------

Leg-Base Chair with Arms

7 1/4"	20 1/2"	25 1/4"	8 3/8"	4°	95°
--------	---------	---------	--------	----	-----

Leg-Base Chair without Arms

7 1/4"	N.A.	N.A.	N.A.	4°	95°
--------	------	------	------	----	-----

Sled-Base Chair with Arms

7 1/4"	20 1/2"	25 1/4"	8 3/8"	4°	95°
--------	---------	---------	--------	----	-----

Sled-Base Chair without Arms

7 1/4"	N.A.	N.A.	N.A.	4°	95°
--------	------	------	------	----	-----

Leg-Base Stool with Arms

7 1/4"	20 1/2"	36 1/2"	8 3/8"	4°	95°
--------	---------	---------	--------	----	-----

Leg-Base Stool without Arms

7 1/4"	N.A.	N.A.	N.A.	4°	95°
--------	------	------	------	----	-----

Player 475 Series Leg-Base Multi-Use Chairs

with Open Arms or without Arms



Tip: Color choices are limited for chairs with textured plastic arms.
▶ Page 292

Tip: Fire Code Seating (FCS) option is available with certain upholstery fabric choices only.
▶ Pages 289–290

Standard Includes		Required to Specify	
▶ Need help? Product details, page 228	<ul style="list-style-type: none"> • Frame: monochromatic color • Arms, if selected: plastic color to match frame color • Upholstery: fabric price group 1 • Bookrack, if selected: will match frame color • Glides, if selected: plastic with stainless steel inserts • Hard composition, dual-wheel casters, if selected; black 	<ol style="list-style-type: none"> 1 Style number 2 Monochromatic color number from seating plastic colors for frame 3 Fabric color number for upholstery 4 Options, if selected (see below) 	▶ See <i>Surface Materials</i> , page 282.

Options	U.S. Price	Required to Specify	
Surface Materials	Upholstery <ul style="list-style-type: none"> • Fabric price group 1 No cost • Fabric price group 2 +\$ 20 • Fabric price group 3 +\$ 40 • Fabric price group 4 +\$ 55 • Fabric price group 5 +\$ 70 • Fabric price group 6 +\$100 • Fabric price group 7 +\$140 • Fabric price group 8 +\$185 • Fabric price group 9 +\$220 • Fabric price group 10 +\$255 • Customer's Own Material (COM) +\$ 30 • Fire Code Seating (FCS) +\$ 50 • Soil-retardant treatment applied to upholstery fabric +\$ 17 	Specify fabric color number. Specify fabric color number. Specify fabric color number. Specify fabric color number. Specify fabric color number. Specify fabric color number. Specify fabric color number. Specify fabric color number. Specify fabric color number. Specify fabric color number. Specify fabric color number. ▶ See <i>Surface Materials Reference Manual</i> to specify. Add suffix F to the style number. Specify <i>with soil-retardant treatment</i> .	▶ See <i>Surface Materials Reference Manual</i> to specify. Add suffix F to the style number. Specify <i>with soil-retardant treatment</i> .
Back and Seat	<ul style="list-style-type: none"> • High back +\$ 27 • Thick seat +\$ 27 • High back and thick seat +\$ 54 	Specify <i>with high back</i> . Specify <i>with thick seat</i> . Specify <i>with high back and thick seat</i> .	Specify <i>with high back</i> . Specify <i>with thick seat</i> . Specify <i>with high back and thick seat</i> .
Glides	<ul style="list-style-type: none"> • Soft glides for use on non-carpeted floors +\$ 5 	Specify <i>with soft glides</i> .	Specify <i>with soft glides</i> .
Casters	<ul style="list-style-type: none"> • Soft, dual-wheel casters for use on hard floors +\$ 18 	Specify <i>with soft casters</i> .	Specify <i>with soft casters</i> .

▶ Detailed dimensions, page 230



For Canadian Pricing
Multiply U.S. Price by 1.38.
▶ See page 1 for details.

Specification Information

Style Number	U.S. Base Price
--------------	-----------------

Smooth Plastic Arms

With Glides

475412M	\$273
----------------	-------

With Glides and Bookrack

475412MB	\$331
-----------------	-------

With Casters

475412MC	\$313
-----------------	-------

Textured Plastic Arms

With Glides

475415M	\$273
----------------	-------

With Glides and Bookrack

475415MB	\$331
-----------------	-------

With Casters

475415MC	\$313
-----------------	-------

Without Arms

With Glides

475410M	\$249
----------------	-------

With Glides and Bookrack

475410MB	\$307
-----------------	-------



For Canadian Pricing
Multiply U.S. Price by 1.38.
▶ See page 1 for details.

Player 475 Series Leg-Base Multi-Use Chairs

with Tablet Arm



Standard Includes		Required to Specify
<ul style="list-style-type: none"> ▶ Need help? Product details, page 228 	<ul style="list-style-type: none"> • Frame: monochromatic color • Tablet arm: laminate • Upholstery: fabric price group 1 • Bookrack, if selected: will match frame color • Glides: plastic with stainless steel inserts 	<ol style="list-style-type: none"> 1 Style number 2 Monochromatic color number from seating plastic colors for frame 3 Fabric color number for upholstery 4 Laminate color number for tablet arm 5 Options, if selected (see below) <ul style="list-style-type: none"> ▶ See <i>Surface Materials</i>, page 282.

Options	U.S. Price	Required to Specify
<p>Surface Materials</p> <p>Upholstery</p> <ul style="list-style-type: none"> • Fabric price group 1 • Fabric price group 2 • Fabric price group 3 • Fabric price group 4 • Fabric price group 5 • Fabric price group 6 • Fabric price group 7 • Fabric price group 8 • Fabric price group 9 • Fabric price group 10 • Customer's Own Material (COM) • Fire Code Seating (FCS) • Soil-retardant treatment applied to upholstery fabric 	<p>No cost</p> <p>+\$ 20</p> <p>+\$ 40</p> <p>+\$ 55</p> <p>+\$ 70</p> <p>+\$100</p> <p>+\$140</p> <p>+\$185</p> <p>+\$220</p> <p>+\$255</p> <p>+\$ 30</p> <p>+\$ 50</p> <p>+\$ 17</p>	<p>Specify fabric color number.</p> <p>Specify fabric color number.</p> <p>Specify fabric color number.</p> <p>Specify fabric color number.</p> <p>Specify fabric color number.</p> <p>Specify fabric color number.</p> <p>Specify fabric color number.</p> <p>Specify fabric color number.</p> <p>Specify fabric color number.</p> <p>▶ See <i>Surface Materials Reference Manual</i> to specify.</p> <p>Add suffix F to the style number.</p> <p>Specify <i>with soil-retardant treatment</i>.</p>
<p>Back and Seat</p> <ul style="list-style-type: none"> • High back • Thick seat • High back and thick seat 	<p>+\$ 27</p> <p>+\$ 27</p> <p>+\$ 54</p>	<p>Specify <i>with high back</i>.</p> <p>Specify <i>with thick seat</i>.</p> <p>Specify <i>with high back and thick seat</i>.</p>
<p>Glides</p> <ul style="list-style-type: none"> • Soft glides for use on non-carpeted floors 	<p>+\$ 5</p>	<p>Specify <i>with soft glides</i>.</p>

Tip: Fire Code Seating (FCS) option is available with certain upholstery fabric choices only.
▶ Pages 289–290

▶ Detailed dimensions, page 230



For Canadian Pricing
Multiply U.S. Price by 1.38.
▶ See page 1 for details.

Specification Information

Style Number	U.S. Base Price
--------------	-----------------



Right-Hand Tablet Arm

475410MTR	\$389
-----------	-------



With Bookrack

475410MTRB	\$447
------------	-------



Left-Hand Tablet Arm

475410MTL	\$389
-----------	-------



With Bookrack

475410MTLB	\$447
------------	-------



For Canadian Pricing
Multiply U.S. Price by 1.38.
▶ See page 1 for details.

Player 475 Series Sled-Base Multi-Use Chairs

with Open Arms or without Arms



Tip: Color choices are limited for chairs with textured plastic arms.

▶ Page 292

Tip: Fire Code Seating (FCS) option is available with certain upholstery fabric choices only.

▶ Pages 289–290

Standard Includes		Required to Specify	
▶ Need help? Product details, page 228	<ul style="list-style-type: none"> • Frame: monochromatic color • Arms, if selected: plastic color to match frame color • Upholstery: fabric price group 1 • Bookrack, if selected: will match frame color • Glides: plastic with stainless steel inserts 	<ol style="list-style-type: none"> 1 Style number 2 Monochromatic color number from seating plastic colors for frame 3 Fabric color number for upholstery 4 Options, if selected (see below) 	▶ See <i>Surface Materials</i> , page 282.

Options	U.S. Price	Required to Specify	
Surface Materials	Upholstery <ul style="list-style-type: none"> • Fabric price group 1 No cost • Fabric price group 2 +\$ 20 • Fabric price group 3 +\$ 40 • Fabric price group 4 +\$ 55 • Fabric price group 5 +\$ 70 • Fabric price group 6 +\$100 • Fabric price group 7 +\$140 • Fabric price group 8 +\$185 • Fabric price group 9 +\$220 • Fabric price group 10 +\$255 • Customer's Own Material (COM) +\$ 30 • Fire Code Seating (FCS) +\$ 50 • Soil-retardant treatment applied to upholstery fabric +\$ 17 	<ul style="list-style-type: none"> Specify fabric color number. Specify fabric color number. Specify fabric color number. Specify fabric color number. Specify fabric color number. Specify fabric color number. Specify fabric color number. Specify fabric color number. Specify fabric color number. Specify fabric color number. 	▶ See <i>Surface Materials Reference Manual</i> to specify. Add suffix F to the style number. Specify <i>with soil-retardant treatment</i> .
Back and Seat	<ul style="list-style-type: none"> • High back +\$ 27 • Thick seat +\$ 27 • High back and thick seat +\$ 54 	<ul style="list-style-type: none"> Specify <i>with high back</i>. Specify <i>with thick seat</i>. Specify <i>with high back and thick seat</i>. 	
Glides	<ul style="list-style-type: none"> • Soft glides for use on non-carpeted floors +\$ 5 	Specify <i>with soft glides</i> .	

▶ Detailed dimensions, page 230



For Canadian Pricing

Multiply U.S. Price by 1.38.

▶ See page 1 for details.

Specification Information

Style Number	U.S. Base Price
--------------	-----------------



Smooth Plastic Arms

475482M	\$352
----------------	-------



With Bookrack

475482MB	\$410
-----------------	-------



Textured Plastic Arms

475485M	\$352
----------------	-------



With Bookrack

475485MB	\$410
-----------------	-------



Without Arms

475480M	\$328
----------------	-------



With Bookrack

475480MB	\$386
-----------------	-------

Player 475 Series



For Canadian Pricing
Multiply U.S. Price by 1.38.
▶ See page 1 for details.

Player 475 Series Sled-Base Multi-Use Chairs

with Tablet Arm



Standard Includes		Required to Specify
<ul style="list-style-type: none"> ▶ Need help? Product details, page 228 	<ul style="list-style-type: none"> • Frame: monochromatic color • Tablet arm: laminate • Upholstery: fabric price group 1 • Bookrack, if selected: will match frame color • Glides: stainless steel 	<ol style="list-style-type: none"> 1 Style number 2 Monochromatic color number from seating plastic colors for frame 3 Fabric color number for upholstery 4 Laminate color number for tablet arm 5 Options, if selected (see below) <ul style="list-style-type: none"> ▶ See <i>Surface Materials</i>, page 282.

Options	U.S. Price	Required to Specify
Surface Materials	Upholstery	
	<ul style="list-style-type: none"> • Fabric price group 1 No cost • Fabric price group 2 +\$ 20 • Fabric price group 3 +\$ 40 • Fabric price group 4 +\$ 55 • Fabric price group 5 +\$ 70 • Fabric price group 6 +\$100 • Fabric price group 7 +\$140 • Fabric price group 8 +\$185 • Fabric price group 9 +\$220 • Fabric price group 10 +\$255 • Customer's Own Material (COM) +\$ 30 • Fire Code Seating (FCS) +\$ 50 • Soil-retardant treatment applied to upholstery fabric +\$ 17 	<ul style="list-style-type: none"> Specify fabric color number. Specify fabric color number. Specify fabric color number. Specify fabric color number. Specify fabric color number. Specify fabric color number. Specify fabric color number. Specify fabric color number. Specify fabric color number. Specify fabric color number. ▶ See <i>Surface Materials Reference Manual</i> to specify. Add suffix F to the style number. Specify <i>with soil-retardant treatment</i>.
Back and Seat	<ul style="list-style-type: none"> • High back +\$ 27 • Thick seat +\$ 27 • High back and thick seat +\$ 54 	<ul style="list-style-type: none"> Specify <i>with high back</i>. Specify <i>with thick seat</i>. Specify <i>with high back and thick seat</i>.
Glides	<ul style="list-style-type: none"> • Soft glides for use on non-carpeted floors +\$ 5 	<ul style="list-style-type: none"> Specify <i>with soft glides</i>.

Tip: Fire Code Seating (FCS) option is available with certain upholstery fabric choices only.
▶ Pages 289–290

▶ Detailed dimensions, page 230



For Canadian Pricing
Multiply U.S. Price by 1.38.
▶ See page 1 for details.

Specification Information

• Style	• U.S.
• Number	• Base
•	• Price



Right-Hand Tablet Arm

475480MTR \$468



With Bookrack

475480MTRB \$526



Left-Hand Tablet Arm

475480MTL \$468



With Bookrack

475480MTLB \$526



For Canadian Pricing
Multiply U.S. Price by 1.38.
▶ See page 1 for details.

Player 475 Series Leg-Base Stools



Tip: Color choices are limited for chairs with textured plastic arms.
▶ Page 292

Tip: Fire Code Seating (FCS) option is available with certain upholstery fabric choices only.
▶ Pages 289–290

Standard Includes		Required to Specify
▶ Need help? Product details, page 228	<ul style="list-style-type: none"> • Frame: monochromatic color • Arms, if selected: plastic color to match frame color • Upholstery: fabric price group 1 • Bookrack, if selected: monochromatic match frame • Glides: plastic with stainless steel inserts 	<ol style="list-style-type: none"> 1 Style number 2 Monochromatic color number from seating plastic colors for frame 3 Fabric color number for upholstery 4 Options, if selected (see below) <p>▶ See <i>Surface Materials</i>, page 282.</p>

Options	U.S. Price	Required to Specify
Surface Materials	Upholstery <ul style="list-style-type: none"> • Fabric price group 1 No cost • Fabric price group 2 +\$ 20 • Fabric price group 3 +\$ 40 • Fabric price group 4 +\$ 55 • Fabric price group 5 +\$ 70 • Fabric price group 6 +\$100 • Fabric price group 7 +\$140 • Fabric price group 8 +\$185 • Fabric price group 9 +\$220 • Fabric price group 10 +\$255 • Customer's Own Material (COM) +\$ 30 • Fire Code Seating (FCS) +\$ 50 • Soil-retardant treatment applied to upholstery fabric +\$ 17 	Specify fabric color number. Specify fabric color number. Specify fabric color number. Specify fabric color number. Specify fabric color number. Specify fabric color number. Specify fabric color number. Specify fabric color number. Specify fabric color number. Specify fabric color number. ▶ See <i>Surface Materials Reference Manual</i> to specify. Add suffix F to the style number. Specify <i>with soil-retardant treatment</i> .
Back and Seat	<ul style="list-style-type: none"> • High back +\$ 27 • Thick seat +\$ 27 • High back and thick seat +\$ 54 	Specify <i>with high back</i> . Specify <i>with thick seat</i> . Specify <i>with high back and thick seat</i> .
Glides	<ul style="list-style-type: none"> • Soft glides for use on non-carpeted floors +\$ 5 	Specify <i>with soft glides</i> .

▶ Detailed dimensions, page 230



For Canadian Pricing
Multiply U.S. Price by 1.38.
▶ See page 1 for details.

Specification Information

• Style	• U.S.
• Number	• Base
•	• Price



Smooth Plastic Arms

475712M \$470



With Bookrack

475712MB \$528



Textured Plastic Arms

475715M \$470



With Bookrack

475715MB \$528



Without Arms

475710M \$446



With Bookrack

475710MB \$504



For Canadian Pricing
Multiply U.S. Price by 1.38.
▶ See page 1 for details.

Player 475 Series Accessories

Bookrack

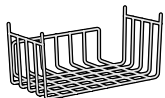

Standard Includes	Required to Specify
-------------------	---------------------

- | | |
|---------------------------------|---|
| • Bookrack: monochromatic color | 1 Style number
2 Monochromatic color number from seating plastic colors for bookrack
▶ See <i>Surface Materials</i> , page 282. |
|---------------------------------|---|

Specification Information	
---------------------------	--

• Style Number	• U.S. Price
475B	\$52

Alignment Device

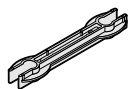

Tip: One pair is required to align two chairs.

Standard Includes	Required to Specify
-------------------	---------------------

- | | |
|--|--------------|
| • Alignment device: black paint only
• Package of 5 pairs | Style number |
|--|--------------|

Specification Information	
---------------------------	--

• Style Number	• U.S. Price
475A	\$52

Ganging Device

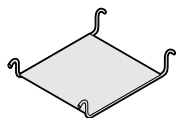

Tip: Use one ganging device for every two chairs.

Standard Includes	Required to Specify
-------------------	---------------------

- | | |
|--|--------------|
| • Ganging device: black paint only
• Package of 2 | Style number |
|--|--------------|

Specification Information	
---------------------------	--

• Style Number	• U.S. Price
475G	\$66



For Canadian Pricing
Multiply U.S. Price by 1.38.
▶ See page 1 for details.

Transport and Storage Dolly

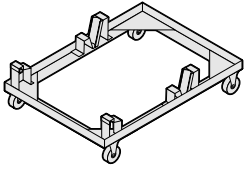

Standard Includes

- Transport and storage dolly: black paint only

Required to Specify

- Style number

Specification Information

• Style Number	• U.S. Price
475D	\$218



For Canadian Pricing
Multiply U.S. Price by 1.38.
▶ See page 1 for details.



Understanding and Specifying Snodgrass 474 Series Multi-Use Chairs

Understanding Snodgrass 474 Series

Details	246
Dimensions	248

Specifying Snodgrass 474 Series

Multi-Use Chairs	250
------------------	-----

Multi-Use Chairs

Multi-use chairs are suitable for use as occasional seating within team spaces, workstations, offices, or wherever extra seating is required.

- Ally 463 Series
- Player 475 Series
- Snodgrass 474 Series

► For additional multi-use chairs, see page 252.

Snodgrass 474 Series

Snodgrass, designed by Warren Snodgrass, offers guest and occasional seating of classic simplicity. With a choice of metal or wood frames, Snodgrass has enduring design that is always in style.

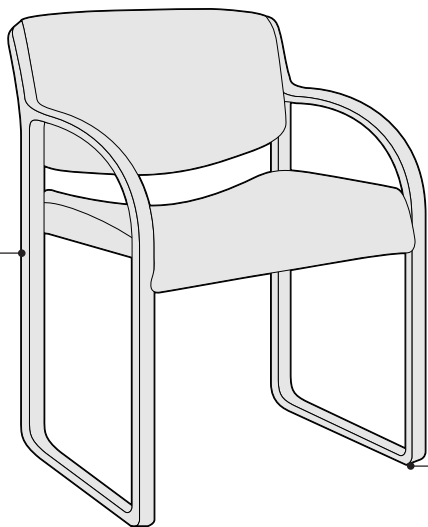

Frame is available in monochromatic colors or wood veneer.

Glides are clear plastic.

Product Details

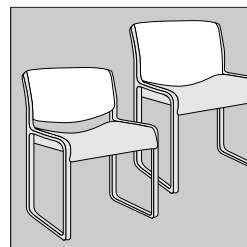

Two back shapes are available, open back or full back.

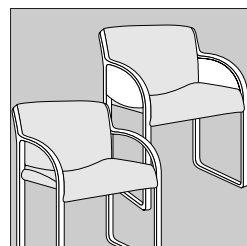

Two arm styles—open and enclosed—are available. Open arm is available on monochromatic and wood models. Enclosed arm is available on wood models. Armless models are also available on monochromatic models.

Surface Materials

▶ See surface materials on page 282 for specific availability or refer to the *Surface Materials Reference Manual* for further information.

Upholstery

- Fabric
- Fabric with soil retardant treatment (option)
- Vinyl
- Leather

Frame

- Monochromatic color from list of seating plastic color numbers can be applied to the frame.
- Wood

Tip: Frames are constructed of solid maple. Finishes applied to maple will match the color of stains applied to oak, walnut, or cherry, but will not show the same natural grain.

Glides

- Clear plastic

All Steelcase seating with standard upholstery fabrics complies with requirements of the BIFMA First Generation Voluntary Upholstered Furniture Flammability Standard, as well as the State of California Technical Bulletin 117. All standard seating is labeled to be in compliance with California TB117.

Programs & Services

▶ See the *Surface Materials Reference Manual* for further detail about programs and services offered for seating.

The Customer's Own Material (COM) Program

offers the opportunity for customers to select fabrics that are not offered through the standard Steelcase surface materials program for use on Steelcase products. Through the COM program, Steelcase will test your materials for application on Steelcase products. Once approved, you can place your order. Steelcase will facilitate the entire ordering process and give you a production schedule. Steelcase will order the COM fabric directly from the textile manufacturer. For up-to-date information regarding fabric test results for all COM fabrics and details regarding yardage requirements for most Seating lines, visit the COM Web site. To locate the COM Web site:

- Visit www.steelcase.com
- Click on "Knowledge & Design"
- Select "Customer's Own Material"

Soil retardants are treatments that provide long-term soil and stain resistance to a fabric without affecting the shade or the integrity of the fabric. The following Steelcase Textiles are available pre-treated with soil retardant. (You do not need to select the soil-retardant option for these fabrics and incur the \$17 upcharge.)

- Canzoné
- Cavalcade
- Jacks
- Link
- Regis
- Rook
- Roulette
- Skittles
- Spyder
- Sweepstakes

Soil-retardant treatment is available on all other seating fabrics at an additional \$17 U.S. per seating unit. To order this option, please select "Soil-Retardant Treatment" under "Optional Accessories."

For soil-retardant treatment on COMs, please select "Soil-Retardant Treatment" under "Optional Accessories." Minimums or additional yardage may be required. Please contact the vendor directly for specific information.

Extended lead times may be necessary for this service.

Contact your Steelcase Sales Service representative at 1.888.STEELCASE (1.888.783.3522).

Fire Codes

▶ See pages 289–290 for upholstery fabrics available for use with FCS modification.

Steelcase offers Fire Code Seating modification (FCS) on nearly all seating models. The most rigorous fire codes in the nation have been developed in California, and the Steelcase FCS modification is designed to meet those codes. Fire Code Seating (FCS) indicates that a product is constructed to meet the strict fire code requirements of high public occupancy areas such as theaters, meeting rooms, and lobbies. The FCS standards will meet both the State of California Home Furnishing Technical Bulletin 133 (Cal TB 133) and Boston Fire Code (BFC). Boston adopted the California Home Furnishing Technical Bulletin TB 133 test standard in 1992.

Local codes may have special requirements for upholstery.

Dimensions

▶ Page 248

Resources

Printed Materials
▶ Snodgrass Brochure (S11006)

Dimensions

Snodgrass 474 Series

• Features	• Overall Depth	Width	Height	• Seat Depth	• Functional Seat Depth	• Seat Width	• Seat Height from Floor	• Back Width	• Back Height from Seat
------------	-----------------	-------	--------	--------------	-------------------------	--------------	--------------------------	--------------	-------------------------

Snodgrass 474 Series

Chair with Open Loop Arms

23½"	22¾"	31½"	21"	17½"	20"	18¼"	20"	14¼"
------	------	------	-----	------	-----	------	-----	------

Chair with Enclosed Arms

23½"	22¾"	31½"	21"	17½"	20"	18¼"	20"	14¼"
------	------	------	-----	------	-----	------	-----	------

Chair without Arms

23½"	22¾"	31½"	21"	17½"	20"	18¼"	20"	14¼"
------	------	------	-----	------	-----	------	-----	------

• Back • Lumbar • Height	• Width • Between • Arms	• Arm • to • Floor	• Arm • Height • from • Seat	• Seat • Pan • Angle	• Angle • Between • Seat and • Back
--------------------------------	--------------------------------	--------------------------	---------------------------------------	----------------------------	--

Chair with Open Loop Arms

7"	20"	25¼"	7"	5°	103°
----	-----	------	----	----	------

Chair with Enclosed Arms

7"	20"	25¼"	7"	5°	103°
----	-----	------	----	----	------

Chair without Arms

7"	20"	25¼"	7"	5°	103°
----	-----	------	----	----	------

Snodgrass 474 Series Multi-Use Chairs

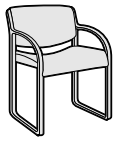

Standard Includes		Required to Specify
<ul style="list-style-type: none"> ▶ Need help? Product details, page 246 	<ul style="list-style-type: none"> • Frame and arms, if selected: monochromatic color, or wood veneer • Upholstery: fabric price group 1 • Glides: clear plastic 	<ol style="list-style-type: none"> 1 Style number 2 Monochromatic color number from seating plastic colors for frame 3 Fabric color number for upholstery 4 Options, if selected (see below) <ul style="list-style-type: none"> ▶ See <i>Surface Materials</i>, page 282.

Options	U.S. Price	Required to Specify
Surface Materials		
Upholstery		
<ul style="list-style-type: none"> • Fabric price group 1 • Fabric price group 2 • Fabric price group 3 • Fabric price group 4 • Fabric price group 5 • Fabric price group 6 • Fabric price group 7 • Fabric price group 8 • Fabric price group 9 • Fabric price group 10 • Leather price group • Customer's Own Material/Leather (COM/COL) • Fire Code Seating (FCS) • Soil-retardant treatment applied to upholstery fabric • Customiz stain on wood 	<ul style="list-style-type: none"> No cost +\$ 20 +\$ 40 +\$ 55 +\$ 70 +\$ 85 +\$100 +\$125 +\$155 +\$175 +\$450 +\$ 30 +\$ 50 +\$ 17 +\$ 24 	<ul style="list-style-type: none"> Specify fabric color number. Specify fabric color number. Specify fabric color number. Specify fabric color number. Specify fabric color number. Specify fabric color number. Specify fabric color number. Specify fabric color number. Specify fabric color number. Specify fabric color number. Specify leather color number. ▶ See <i>Surface Materials Reference Manual</i> to specify. Add suffix F to the style number. Specify <i>with soil-retardant treatment</i>. ▶ See <i>Surface Materials Reference Manual</i>.

Tip: Fire Code Seating (FCS) option is available with certain upholstery fabric choices only.
▶ Pages 289–290

▶ Detailed dimensions, page 248



For Canadian Pricing
Multiply U.S. Price by 1.38.
▶ See page 1 for details.

Specification Information

Open Loop Arms with Open Back



• Style
Number
• U.S.
Base
Price

Open Loop Arms With Full Back



• Style
Number
• U.S.
Base
Price

Enclosed Arms with Full Back



• Style
Number
• U.S.
Base
Price

Monochromatic

474419M \$537

474429M \$552

N.A.

Wood

474419W \$829

474429W \$844

474427W \$1030

Armless with Open Back



• Style
Number
• U.S.
Base
Price

Armless with Full Back



• Style
Number
• U.S.
Base
Price

Monochromatic

474410M \$505

474420M \$520



For Canadian Pricing
Multiply U.S. Price by 1.38.
▶ See page 1 for details.

Additional Multi-Use Chairs

Jersey Multi-Use Chairs

With Arms



Without Arms



With Arms and Casters



Without Arms and With Casters



▶ See pages 134–137

Sensor 458 Series Size II Mid-Back Multi-Use Chairs

Sled-Base



▶ See page 154

Rally 457 Series Mid-Back Multi-Use Chairs

Arms With Plastic Arm Caps



Without Arms



Sled-Base With Arms and Plastic Arm Caps



▶ See page 166

Protégé 433 Series Multi-Use Chairs

Arms



Arms With Soft Arm Caps



Without Arms



Arms



Arms With Soft Arm Caps



▶ See pages 176–178

Cachet 487 Series Multi-Use Chairs

With Flip-Up Arms



Without Arms



▶ See pages 186–187

Understanding and Specifying Parade! 470 Series Stackable Chairs

Understanding Parade! 470 Series

Details	254
Dimensions	256

Specifying Parade! 470 Series

Stackable Chairs	258
Accessories	259

Stackable Chairs

Stackable chairs offer flexibility and ease of use in classrooms, auditoriums, or wherever extra seating is required.

- Parade! 470 Series
- Max-Stacker 472 Series
- Max-Stacker II 473 Series
- Cachet 487 Series
- Player 475 Series
- Leg-Base Chairs
- Ally 463 Series

Parade! 470 Series

Parade! offers a stylish choice in stackers with a plastic contoured seat and back that encourages proper posture. Constructed with a half-inch carbon steel rod and a unique plastic seat and back for strength and durability, the arch and cantilever frame makes Parade! a good selection for dining areas and offices as well as classrooms and auditoriums.

Seat and back are plastic to provide strength and durability.

Arms are available with or without colored plastic arm caps.

Clear plastic glides are standard. Soft glides, optional, are recommended for use on non-carpeted floors.

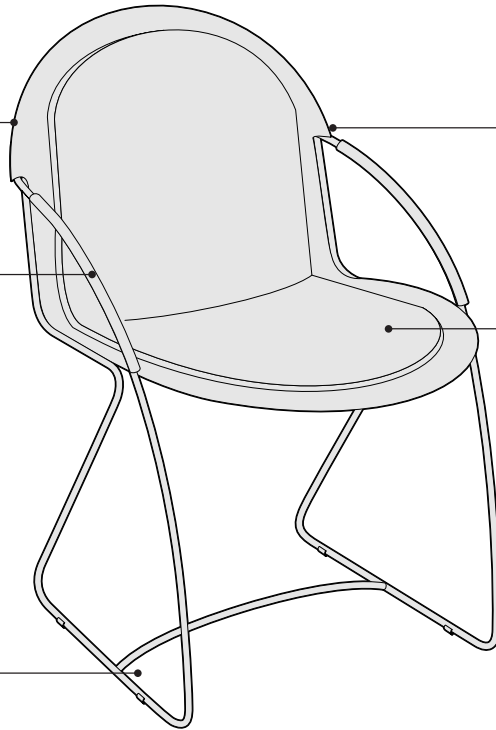

Wire rod frame is 1/2"-diameter carbon steel.

Upholstered foam cushion is available for the seat and back.

Product Details

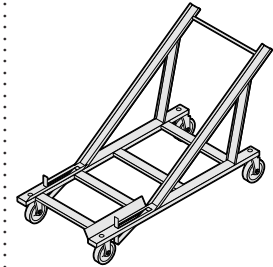

Transport and storage dolly is available to stack, move, and store up to 24 non-upholstered or 16 upholstered chairs. Because stacking bumpers are used on upholstered models, stacking capacity is 16 chairs per dolly.

Fully loaded transport dolly measures 54 1/2"D x 21 3/8"W x 68 1/2"H.

Without transport dolly stack can be up to six chairs high.

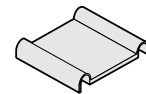

Alignment device is available to temporarily link chairs together in the field for evenly spaced rows. Chairs can be unlinked easily. Spacing between chairs linked with alignment device is 2 1/4".

Surface Materials

▶ See surface materials on page 282 for specific availability or refer to the *Surface Materials Reference Manual* for further information.

Hard components (frame and arms)

- Seating coating
- 9201 Polished Chrome

Seat and back

- Plastic color

Upholstered cushion

- Fabric
- Fabric with soil retardant treatment (option)

Arm caps

- Plastic color

Glides

- Clear plastic
- Soft

All Steelcase seating with standard upholstery fabrics complies with requirements of the BIFMA First Generation Voluntary Upholstered Furniture Flammability Standard, as well as the State of California Technical Bulletin 117. All standard seating is labeled to be in compliance with California TB117.

Programs & Services

▶ See the *Surface Materials Reference Manual* for further detail about programs and services offered for seating.

The Customer's Own Material (COM) Program

offers the opportunity for customers to select fabrics that are not offered through the standard Steelcase surface materials program for use on Steelcase products. Through the COM program, Steelcase will test your materials for application on Steelcase products. Once approved, you can place your order. Steelcase will facilitate the entire ordering process and give you a production schedule. Steelcase will order the COM fabric directly from the textile manufacturer. For up-to-date information regarding fabric test results for all COM fabrics and details regarding yardage requirements for most Seating lines, visit the COM Web site. To locate the COM Web site:

- Visit www.steelcase.com
- Click on "Knowledge & Design"
- Select "Customer's Own Material"

Soil retardants are treatments that provide long-term soil and stain resistance to a fabric without affecting the shade or the integrity of the fabric. The following Steelcase Textiles are available pre-treated with soil retardant. (You do not need to select the soil-retardant option for these fabrics and incur the \$17 upcharge.)

- Canzoné
- Cavalcade
- Jacks
- Link
- Regis
- Rook
- Roulette
- Skittles
- Spyder
- Sweepstakes

Soil-retardant treatment is available on all other seating fabrics at an additional \$17 U.S. per seating unit. To order this option, please select "Soil-Retardant Treatment" under "Optional Accessories."

For soil-retardant treatment on COMs, please select "Soil-Retardant Treatment" under "Optional Accessories." Minimums or additional yardage may be required. Please contact the vendor directly for specific information.

Extended lead times may be necessary for this service.

Contact your Steelcase Sales Service representative at 1.888.STEELCASE (1.888.783.3522).

Steelcase Fire Code Seating (FCS) is not available on Parade! seating

Local codes may have special requirements for upholstery.

Dimensions

▶ Page 256

Resources

Printed Materials

▶ Stackable Seating Brochure (02-0002354)

Dimensions

Parade! 470 Series

•Features	•Overall •Depth	Width	Height	•Seat •Depth	•Functional •Seat •Depth	•Seat •Width	•Seat •Height •from •Floor	•Back •Width	•Back •Height •from •Seat
-----------	--------------------	-------	--------	-----------------	--------------------------------	-----------------	-------------------------------------	-----------------	------------------------------------

Parade! 470 Series

Chair without Arm Caps

23"	20½"	32"	17"	17"	19"	17½"	19"	16½"
-----	------	-----	-----	-----	-----	------	-----	------

Chair with Arm Caps

23"	21"	32"	17"	17"	19"	17½"	19"	16½"
-----	-----	-----	-----	-----	-----	------	-----	------

• Back Lumbar Height	• Width Between Arms	• Arm to Floor	• Arm Height from Seat	• Seat Pan Angle	• Angle Between Seat and Back
----------------------	----------------------	----------------	------------------------	------------------	-------------------------------

Chair without Arm Caps

10"	19¼"	24¾"	7¼"	7°	101°
-----	------	------	-----	----	------

Chair with Arm Caps

10"	19"	25"	7½"	7°	101°
-----	-----	-----	-----	----	------

Alignment Device

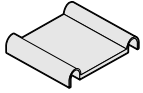

Standard Includes	Required to Specify
• Carton of 12 alignment devices: black plastic only	Style number

Specification Information

Style Number	U.S. Price
470G	\$24

Transport and Storage Dolly

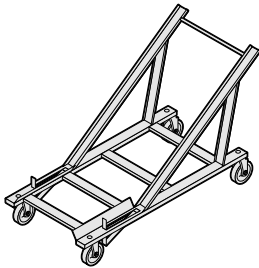

Standard Includes	Required to Specify
• Transport and storage dolly: black paint only	Style number

Specification Information

Style Number	U.S. Price
470D	\$386



For Canadian Pricing
Multiply U.S. Price by 1.38.
▶ See page 1 for details.



Understanding and Specifying Max-Stacker 472 Series Stackable Chairs

Understanding Max-Stacker 472 Series

Details	262
Dimensions	264

Specifying Max-Stacker 472 Series

Stackable Chairs	266
Accessories	268

Stackable Chairs

Stackable chairs offer flexibility and ease of use in classrooms, auditoriums, or wherever extra seating is required.

- Parade! 470 Series
- Max-Stacker 472 Series
- Max-Stacker II 473 Series
- Player 475 Series Leg-Base Chairs
- Ally 463 Series

Max-Stacker 472 Series

Max-Stacker provides stackable seating for high-traffic applications. Its clean lines and durable steel rod frame have made the Max-Stacker a universally popular stacker selection.

Tablet arms and bookracks are available factory or field installed.

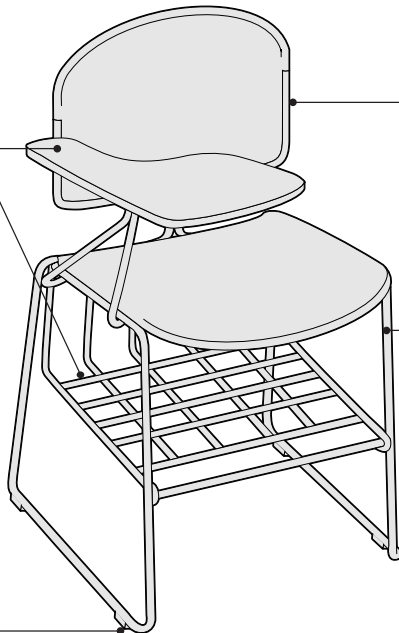

Plastic glides are standard. Soft glides, optional, are recommended for use on non-carpeted floors.

Back and seat are available in flexible, contoured plastic.

Two-piece wire-rod frame is 7/16" diameter carbon steel for strength and durability.

Product Details

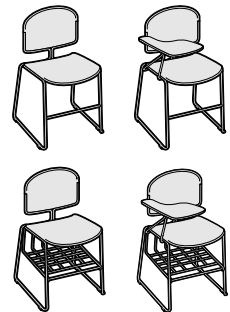

Four models are available—chairs without arms, chairs with bookracks, chairs with tablet arms, and chairs with a combination of bookrack and tablet arm.

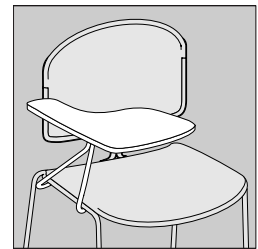

Tablet arms provide a writing surface that is 12½"D x 11⅞"W. They are available in left- or right-hand models.

Clearance between tablet arm and seat is 7¼"H. Tablet arm tilts for easy entrance and exit from chair.

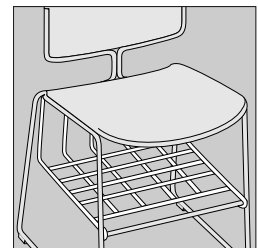

Bookrack is available factory or field installed for convenient storage of notebooks and purses.

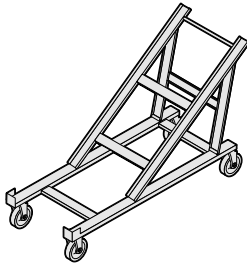

Transport and storage dolly is available to stack, move, and store up to 45 non-upholstered chairs. Chairs with bookracks and tablet arms cannot be stacked.

Unloaded transport dolly measures 55"D x 22"W x 37½"H.

Fully loaded transport dolly measures 57"D x 22"W x 68½"H.

Without transport dolly stack can be up to 12 chairs high.

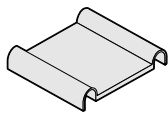

Alignment device is available to temporarily link chairs without tablet arms together in the field for evenly spaced rows. Chairs can be unlinked easily. Spacing between chairs linked with alignment device is 2¼".

Surface Materials

▶ See surface materials on page 282 for specific availability or refer to the *Surface Materials Reference Manual* for further information.

Hard components (frame)

- Seating coating
- 9201 Polished Chrome

Back and seat

- Plastic color

Bookrack

- Coated to match the frame color on seating coated models
- 9201 Polished Chrome on Polished Chrome models

Tablet arms

- Laminate

Glides

- Clear plastic
- Soft

Programs & Services

▶ See the *Surface Materials Reference Manual* for further detail about programs and services offered for seating.

Dimensions

▶ Page 264

Resources

Printed Materials

▶ Stackable Seating Brochure (02-0002354)

Dimensions

Max-Stacker 472 Series

• Overall • Depth	Width	Height	• Seat • Depth	• Functional • Seat • Depth	• Seat • Width	• Seat • Height • from • Floor	• Back • Width	• Back • Height • from • Seat	• Back • Lumbar • Height
Max-Stacker 472 Series									
21½"	20"	30¼"	17¾"	16¾"	18¼"	17½"	18¼"	14¾"	9½"

• Width • Between • Arms	• Arm • to • Floor	• Arm • Height • from • Seat	• Seat • Pan • Angle	• Angle • Between • Seat and • Back
N.A.	N.A.	N.A.	8°	93°

Max-Stacker 472 Series Stackable Chairs



Standard Includes		Required to Specify	
<ul style="list-style-type: none"> ▶ Need help? Product details, page 262 	<ul style="list-style-type: none"> • Frame: seating coating or 9201 Polished Chrome • Seat and back: plastic • Tablet arm, if selected: laminate • Bookrack, if selected: high-wear coating or 9201 Polished Chrome • Glides: plastic 		<ol style="list-style-type: none"> 1 Style number 2 Seating coating color number for frame and bookrack 3 Plastic color number for back and seat 4 Laminate color number for tablet arm 5 Options, if selected (see below) <ul style="list-style-type: none"> ▶ See <i>Surface Materials</i>, page 282.
Options		U.S. Price	Required to Specify
Glides	<ul style="list-style-type: none"> • Soft glides for use on non-carpeted floors 	+\$5	Specify <i>with soft glides</i> .

▶ Detailed dimensions, page 264



For Canadian Pricing
 Multiply U.S. Price by 1.38.
 ▶ See page 1 for details.

Specification Information

• Frame Finish	• Style Number	• U.S. Base Price
----------------	----------------	-------------------



Without Arms

Coated frame	472410N	\$122
Polished Chrome frame	472410	\$122



With Tablet Arm

Right-Hand

Coated frame	472410NTR	\$227
Polished Chrome frame	472410TR	\$227



Left-Hand

Coated frame	472410NTL	\$227
Polished Chrome frame	472410TL	\$227



With Bookrack

Coated frame	472410NBR	\$186
Polished Chrome frame	472410BR	\$186



With Right-Hand Tablet Arm

Coated frame	472410NTRB	\$291
Polished Chrome frame	472410TRB	\$291



With Left-Hand Tablet Arm

Coated frame	472410NTLB	\$291
Polished Chrome frame	472410TLB	\$291



For Canadian Pricing
Multiply U.S. Price by 1.38.
▶ See page 1 for details.

Max-Stacker 472 Series Accessories

Tablet Arm Assembly



Standard Includes	Required to Specify
<ul style="list-style-type: none"> • Tablet arm frame: seating coating or 9201 Polished Chrome • Tablet arm worksurface: laminate 	<ul style="list-style-type: none"> 1 Style number 2 Laminate color number 3 Color number for tablet arm frame ▶ See <i>Surface Materials</i>, page 282.

Specification Information	
• Style Number	• U.S. Price
Right-hand	
472TAR	\$105
Left-hand	
472TAL	\$105
•	•

Bookrack Assembly



Standard Includes	Required to Specify
<ul style="list-style-type: none"> • Bookrack assembly: seating coating or 9201 Polished Chrome 	<ul style="list-style-type: none"> 1 Style number 2 Color number for bookrack ▶ See <i>Surface Materials</i>, page 282.

Specification Information	
• Style Number	• U.S. Price
472BR	\$64
•	•

Alignment Device

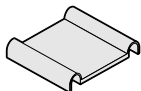

Standard Includes	Required to Specify
<ul style="list-style-type: none"> • Carton of 12 alignment devices: black plastic only 	<ul style="list-style-type: none"> Style number

Specification Information	
• Style Number	• U.S. Price
472G	\$24
•	•



For Canadian Pricing
 Multiply U.S. Price by 1.38.
 ▶ See page 1 for details.

Transport and Storage Dolly

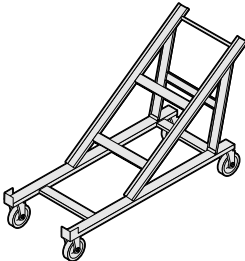

Standard Includes	Required to Specify
-------------------	---------------------

- | | |
|---|--------------|
| • Transport and storage dolly: black paint only | Style number |
|---|--------------|

Specification Information	
Style Number	U.S. Price

473D	\$350
------	-------



For Canadian Pricing
Multiply U.S. Price by 1.38.
▶ See page 1 for details.



Understanding and Specifying Max-Stacker II 473 Series Stackable Chairs

Understanding Max-Stacker II 473 Series

Details	272
Dimensions	274

Specifying Max-Stacker II 473 Series

Stackable Chairs	276
Accessories	278

Stackable Chairs

Stackable chairs offer flexibility and ease of use in classrooms, auditoriums, or wherever extra seating is required.

- Parade! 470 Series
- Max-Stacker 472 Series
- Max-Stacker II 473 Series
- Player 475 Series Leg-Base Chairs
- Ally 463 Series

Max-Stacker II 473 Series

Max-Stacker II offers different visuals with rounded back and curved lines in another great stacking chair.

Tablet arms and bookracks are available factory or field installed.

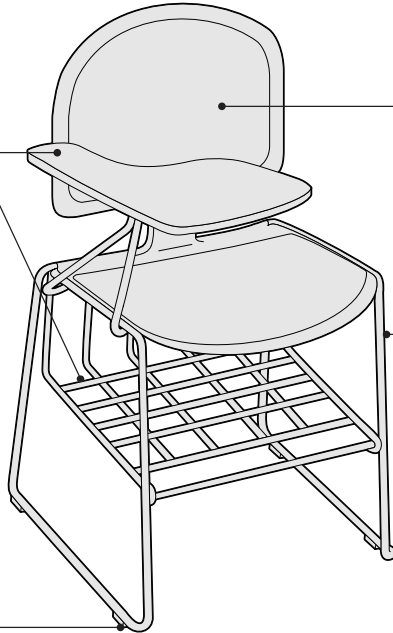

Flexible, contoured back and seat are available in plastic or with upholstered cushions.

Two-piece wire-rod frame is $\frac{7}{16}$ "-diameter carbon steel for strength and durability.

Plastic glides are standard. Soft glides, optional, are recommended for use on non-carpeted floors.

Product Details

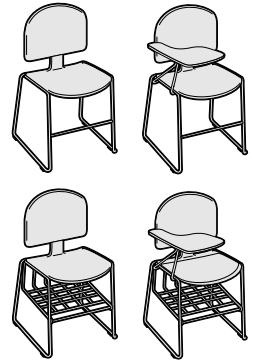

Four models are available—chairs without arms, chairs with bookracks, chairs with tablet arms, and chairs with a combination of bookrack and tablet arm.

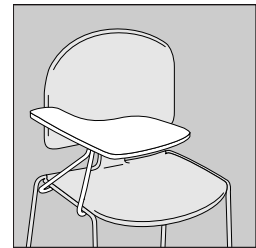

Tablet arms provide a writing surface that is $12\frac{1}{2}$ "D x $11\frac{3}{8}$ "W. They are available in left- or right-hand models.

Clearance between tablet arm and seat is $7\frac{1}{4}$ "H. Tablet arm tilts for easy entrance and exit from chair.

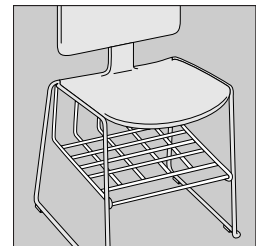

Bookrack is available factory or field installed for convenient storage of notebooks and purses.

Stacking bumpers are provided on upholstered models to protect the fabric when chairs are stacked.

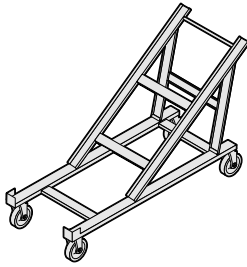

Transport and storage dolly is available to stack, move, and store up to 35 non-upholstered or 25 upholstered chairs. Chairs with bookracks and tablet arms cannot be stacked.

Unloaded transport dolly measures 55"D x 22"W x 37½"H.

Fully loaded transport dolly measures 57"D x 22"W x 68½"H.

Without transport dolly stack can be up to 12 chairs high.

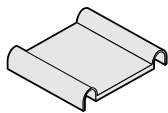

Alignment device is available to temporarily link chairs together in the field for evenly spaced rows. Chairs can be unlinked easily. Spacing between chairs linked with alignment device is 2¼".

Surface Materials

▶ See surface materials on page 282 for specific availability or refer to the *Surface Materials Reference Manual* for further information.

Hard components (frame)

- Seating coating
- 9201 Polished Chrome

Back and seat

- Plastic color
- Upholstery

Upholstery

- Fabric
- Fabric with soil retardant treatment (option)

Bookrack

- Coated to match the frame color on seating coated models
- 9201 Polished Chrome on Polished Chrome models

Tablet arms

- Laminate

Glides

- Clear plastic
- Soft

All Steelcase seating with standard upholstery fabrics complies with requirements of the BIFMA First Generation Voluntary Upholstered Furniture Flammability Standard, as well as the State of California Technical Bulletin 117. All standard seating is labeled to be in compliance with California TB117.

Programs & Services

▶ See the *Surface Materials Reference Manual* for further detail about programs and services offered for seating.

The Customer's Own Material (COM) Program

offers the opportunity for customers to select fabrics that are not offered through the standard Steelcase surface materials program for use on Steelcase products. Through the COM program, Steelcase will test your materials for application on Steelcase products. Once approved, you can place your order. Steelcase will facilitate the entire ordering process and give you a production schedule. Steelcase will order the COM fabric directly from the textile manufacturer. For up-to-date information regarding fabric test results for all COM fabrics and details regarding yardage requirements for most Seating lines, visit the COM Web site. To locate the COM Web site:

- Visit www.steelcase.com
- Click on "Knowledge & Design"
- Select "Customer's Own Material"

Soil retardants are treatments that provide long-term soil and stain resistance to a fabric without affecting the shade or the integrity of the fabric. The following Steelcase Textiles are available pre-treated with soil retardant. (You do not need to select the soil-retardant option for these fabrics and incur the \$17 upcharge.)

- Canzoné
- Cavalcade
- Jacks
- Link
- Regis
- Rook
- Roulette
- Skittles
- Spyder
- Sweepstakes

Soil-retardant treatment is available on all other seating fabrics at an additional \$17 U.S. per seating unit. To order this option, please select "Soil-Retardant Treatment" under "Optional Accessories."

For soil-retardant treatment on COMs, please select "Soil-Retardant Treatment" under "Optional Accessories." Minimums or additional yardage may be required. Please contact the vendor directly for specific information.

Extended lead times may be necessary for this service.

Contact your Steelcase Sales Service representative at 1.888.STEELCASE (1.888.783.3522).

Steelcase Fire Code Seating (FCS) is not available on Max-Stacker II seating.

Local codes may have special requirements for upholstery.

Dimensions

▶ Page 274

Resources

Printed Materials

▶ Stackable Seating Brochure (02-0002354)

Dimensions

Max-Stacker II 473 Series

Overall Depth	Width	Height	Seat Depth	Functional Seat Depth	Seat Width	Seat Height from Floor	Back Width	Back Height from Seat	Back Lumbar Height
Max-Stacker II 473 Series									
22¾"	19¾"	33¼"	19"	17"	18¼"	17½"	18¼"	17¾"	10"

• Width • Between • Arms	• Arm • to • Floor	• Arm • Height • from • Seat	• Seat • Pan • Angle	• Angle • Between • Seat and • Back
--------------------------------	--------------------------	---------------------------------------	----------------------------	--

N.A.	N.A.	N.A.	8°	93°
------	------	------	----	-----

Max-Stacker II 473 Series Stackable Chairs



	Standard Includes	Required to Specify
▶ Need help? Product details, page 272	<ul style="list-style-type: none"> • Frame: seating coating or 9201 Polished Chrome • Back and seat: plastic • Tablet arm, if selected: laminate • Bookrack, if selected: high-wear coating or 9201 Polished Chrome • Glides: plastic 	<ol style="list-style-type: none"> 1 Style number 2 Seating coating color number for frame 3 Plastic color number for back and seat 4 Laminate color number for tablet arm 5 Options, if selected (see below) <p>▶ See <i>Surface Materials</i>, page 282.</p>

	Options	U.S. Price	Required to Specify
Surface Materials	Upholstered seat and back		
	• Fabric price group 1	+\$103	Add suffix U to the style number and specify fabric color number.
	• Fabric price group 2	+\$123	Add suffix U to the style number and specify fabric color number.
	• Fabric price group 3	+\$143	Add suffix U to the style number and specify fabric color number.
	• Fabric price group 4	+\$158	Add suffix U to the style number and specify fabric color number.
	• Fabric price group 5	+\$173	Add suffix U to the style number and specify fabric color number.
	• Fabric price group 6	+\$188	Add suffix U to the style number and specify fabric color number.
	• Fabric price group 7	+\$203	Add suffix U to the style number and specify fabric color number.
	• Fabric price group 8	+\$228	Add suffix U to the style number and specify fabric color number.
	• Fabric price group 9	+\$258	Add suffix U to the style number and specify fabric color number.
	• Fabric price group 10	+\$278	Add suffix U to the style number and specify fabric color number.
	• Customer's Own Material (COM)	+\$133	▶ See <i>Surface Materials Reference Manual</i> to specify.
	• Soil-retardant treatment applied to upholstery fabric	+\$ 17	Specify <i>with soil-retardant treatment</i> .
Glides	• Soft glides for use on non-carpeted floors	+\$ 5	Specify <i>with soft glides</i> .

▶ Detailed dimensions,
page 274



For Canadian Pricing
Multiply U.S. Price by 1.38.
▶ See page 1 for details.

Specification Information

Frame Finish	Style Number	U.S. Base Price
--------------	--------------	-----------------

Without Arms

Coated frame	473410N	\$142
Polished Chrome frame	473410	\$142

With Tablet Arm

Right-Hand

Coated frame	473410NTR	\$247
Polished Chrome frame	473410TR	\$247

Left-Hand

Coated frame	473410NTL	\$247
Polished Chrome frame	473410TL	\$247

With Bookrack

Coated frame	473410NB	\$206
Polished Chrome frame	473410B	\$206

With Right-Hand Tablet Arm

Coated frame	473410NTRB	\$311
Polished Chrome frame	473410TRB	\$311

With Left-Hand Tablet Arm

Coated frame	473410NTLB	\$311
Polished Chrome frame	473410TLB	\$311



For Canadian Pricing
Multiply U.S. Price by 1.38.
▶ See page 1 for details.

Max-Stacker II 473 Series Accessories

Tablet Arm Assembly

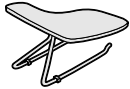

Standard Includes	Required to Specify
<ul style="list-style-type: none"> Tablet arm frame: seating coating or 9201 Polished Chrome Tablet arm worksurface: laminate 	<ul style="list-style-type: none"> 1 Style number 2 Laminate color number 3 Color number for tablet arm frame ▶ See <i>Surface Materials</i>, page 282.

Specification Information

Style Number	U.S. Price
Right-Hand	
473TR	\$105
Left-Hand	
473TL	\$105

Bookrack Assembly



Standard Includes	Required to Specify
<ul style="list-style-type: none"> Bookrack assembly: seating coating or 9201 Polished Chrome 	<ul style="list-style-type: none"> 1 Style number 2 Color number for bookrack ▶ See <i>Surface Materials</i>, page 282.

Specification Information

Style Number	U.S. Price
473B	\$64

Alignment Device

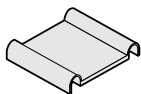

Standard Includes	Required to Specify
<ul style="list-style-type: none"> Carton of 12 alignment devices: black plastic only 	<ul style="list-style-type: none"> Style number

Specification Information

Style Number	U.S. Price
473G	\$24



For Canadian Pricing
 Multiply U.S. Price by 1.38.
 ▶ See page 1 for details.

Transport and Storage Dolly

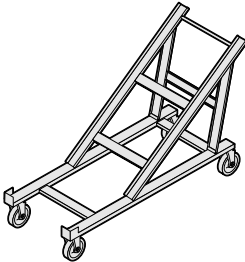

Standard Includes	Required to Specify
<ul style="list-style-type: none"> • Transport and storage dolly: black paint only 	<ul style="list-style-type: none"> • Style number

Specification Information

Style Number	U.S. Price
473D	\$350

Max-Stacker II 473 Series

 **For Canadian Pricing**
Multiply U.S. Price by 1.38.
▶ See page 1 for details.



Surface Materials

Surface Materials	282
Steelcase Classics Collection Upholstery Matrix	287
DesignTex Graded-In Seating Upholstery Matrix	288
Fire Code Seating Upholstery Matrix	289
Fire Code Seating Upholstery Matrix for DesignTex	290
Color Availability Matrix	292
Special Features	294

Surface Materials

This listing includes all the surface material choices that are available for the products in this specification guide

Resources

For more information about surface materials, refer to the following resources:

Surface Materials Reference Manual

This publication provides:

- An explanation of the surface materials program
- “Available on” matrices
- Vertical surface fabric and seating upholstery selection listing
- Pricing for surface materials
- Technical data for surface materials
- Surface material care and cleaning instructions

Surface Materials Finishes Binder

includes:

- Surface Materials Reference Manual
- A complete set of swatch cards for hard surfaces

Surface Materials Vertical Surface Fabric Binder

includes:

- A complete set of swatch cards for vertical surface fabric

Surface Materials Seating Upholstery Binder

includes:

- Designtex Graded-In Catalog
- A complete set of swatch cards for seating upholstery

Surface Materials Tool Box

provides 3" x 3" samples of the following surface materials:

- Vertical surface fabric
- Seating upholstery
- Wood
- Paint
- Laminate

Form number S8150

Plastic

Not every plastic color is available on every plastic component.

▶ Refer to the *Color Availability Matrix* on page 292 before specifying.

6205	Black
6206	Burgundy
6250	Coffee
6256	Graphite
6259	Midnight
6268	Navy
6296	Sterling
6301	Aegean
6302	Baltic
6303	Pomegranate
6421	Ash
6694	Slate

Seating Coating

Available on:

- Parade! 470 Series
- Max-Stacker 472 Series
- Max-Stacker II 473 Series

7000	Black
7005	Coffee
7011	Graphite

Paint

Available on:

- Jersey Series work chairs

4799	Platinum (metallic paint)
------	---------------------------

Available on:

- Jersey Series guest chairs

4799	Platinum (metallic paint)
7207	Black (textured paint)

Metal

Metal finishes are not available on every chair.

▶ Refer to the *Color Availability Matrix* on page 292 before specifying.

8046	Polished Aluminum
9201	Polished Chrome

Laminate

Not every laminate color is available on every chair.

▶ Refer to the *Color Availability Matrix* on page 292 before specifying.

2412	Natural Cherry
2421	Medium Cherry
2511	Winter on Maple
2632	Medium Oak
2711	Natural Walnut
2722	Cream
2746	Black
2759	Warm White
2771	Medium Mahogany on Walnut
2810	Dawn
2811	Mist

Wood

Available on:

- Snodgrass 474 Series chair frames

Tip: Frames are constructed of solid maple. Finishes applied to maple will match the color of stains applied to oak, walnut, or cherry, but will not show the same natural grain.

3412	Natural Cherry
3422	Medium Cherry
3562	Linseed
3572	Amber Maple
3582	Winter
3592	Blonde
3632	Medium Oak
3642	Natural Oak
3712	Natural Walnut
3722	Dark Mahogany on Walnut
3742	Autumn Walnut
3772	Medium Mahogany on Walnut
3792	Black Walnut

Customiz stain is a service that allows you to create your own stain color. Minimum order quantities, per unit up-charges, and a one-time customer processing fee apply. ▶ See the *Surface Materials Reference Manual* for more information.

Coach Leather

Available on:

- Leap 462 Series pillowed upholstery
- Leap 462 Series Coach Edition leather work chairs
- Leap 464 Series WorkLounge and Ottoman Coach Edition

Leather with Matching Thread

CL01	Black with matching thread
CL02	Mahogany with matching thread
CL03	Bordeaux with matching thread
CL04	Racing Green with matching thread
CL05	Bright Navy with matching thread
CL06	Camel with matching thread
CL13	Bright Red with matching thread
CL21	Sisal with matching thread
CL23	Burnished Saddle with matching thread
CL25	Parchment with matching thread
CL27	Cobalt with matching thread

Available on:

- Leap 462 Series Coach Edition leather work chairs

Leather with Contrasting Thread

CL07	Black with contrasting thread
CL08	Mahogany with contrasting thread
CL09	Bordeaux with contrasting thread
CL10	Racing Green with contrasting thread
CL11	Bright Navy with contrasting thread
CL12	Camel with contrasting thread
CL14	Bright Red with contrasting thread
CL22	Sisal with contrasting thread
CL24	Burnished Saddle with contrasting thread
CL28	Cobalt with contrasting thread

Wool Suede Too

Applies to:

- Leap 464 Series WorkLounge

101	Stone
102	Tan
103	Pecan
201	Sesame
301	Blush
302	Persimmon
303	Cranberry
401	Ink
402	Charcoal
403	China
501	Green Tea
502	Eucalyptus
503	Patina
504	Juniper
505	Olive
601	Jam
701	Squash
702	Ginger
801	Dust
802	Mineral
803	Shale
804	Black

Elmo Rustical Leather

Applies to:

- Leap 464 Series WorkLounge

04004	Suffron
12001	Mushroom
12011	Light Grey
17009	Wedgwood
17061	Lilac
18001	Gray Green
22679	Beige
33007	Brown
33286	Rust
43236	Camel
43632	Honey
45056	Sun Ray
48059	Field Green
53301	Red Brown
55057	Crimson
55063	Flame
57016	Deep Purple
87055	Azure
91722	Smoke
93287	Charbrown
93327	Loam
95060	Wine
97054	Twilight
97952	Deep Blue
98953	Mist Green
99991	Ebony

Vest Material

Applies to:

- Leap 462 Series

5056 Black

Mesh

Applies to:

- Jersey Series

T084 Black

T085 Grey

T086 White

T087 Yellow

T088 Orange

T089 Red

T090 Green

T091 Blue

Pullover

Applies to:

- Jersey Series

T092 Black

T095 Yellow

T096 Orange

T097 Red

T098 Green

T099 Blue

3D Knit

Applies to:

- Think 465 Series

5064 Black

5065 Coconut

5066 Malt

5067 Root Beer

5068 Charcoal

5069 Ink

Upholstery

Not every upholstery is available on every chair.

▶ Refer to the *Steelcase**Classics Collection**Upholstery Matrix* on page 287 before specifying.**Classics Collection**

Surface materials in the Classics Collection are timeless. These materials should be available for a minimum of 10 years from the date the material is introduced into the Classics Collection. The Classics Collection includes the following fabrics in Price Groups 1 through 3 and the Leather Price Group:

Price Group 1**Buzz2**

5F00 Yellow
5F01 Camel
5F02 Orange
5F03 Tomato
5F04 Red
5F05 Burgundy
5F06 Sky
5F07 Blue
5F08 Navy
5F09 Blue-Green
5F10 Grape
5F11 Eggplant
5F12 Celery
5F13 Green
5F14 Forest
5F15 Stone
5F16 Grey
5F17 Black

Jacks

5B61 Taupe
5B62 Nutmeg
5B63 Camel
5B64 Pewter
5B65 Rosewood
5B66 Plum
5B67 Lupine
5B68 Lichen
5B69 Ocean
5B70 Midnight

Link

5A20 Burgundy
5A21 Rust
5A23 Green
5A24 Blue
5A25 Navy
5A26 Purple
5A27 Black
5A28 Ocean
5A29 Lichen
5A30 Chamois

Seating Vinyl

5800 Cardinal
5801 Topaz
5802 Ocean
5803 Sky
5804 Lupine
5805 Foggy Night
5806 Aegean
5807 Harbor
5808 Eggplant
5809 Black
5810 Forest
5812 Navy
5813 Currant

Price Group 2**Canzone**

5514 Teal
5515 Raspberry
5517 Kiwi
5518 Plum
5519 Mauve
5521 Fog
5525 Nickel
5526 Beechnut
5529 Fennel
5531 Horizon

Cavalcade

5209 Charcoal
5215 Blueweed
5216 Tanbark
5217 Chicory
5218 Camel
5219 Lichen
5220 Sky
5225 Currant
5291 Mallard
5292 Ocean

Cricket

5A84 Plum
5A85 Camel
5A86 Charcoal
5A87 Black
5A88 Cinnamon
5A89 Rosewood
5A90 Currant
5A91 Spearmint
5A92 Sky
5A93 Midnight
5A94 Lichen
5A95 Ocean
5A96 Forest

Regis

5267 Black
5275 Blue Blue Violet
5282 Blue Blue Green
5283 Blue
5R02 Cardinal
5R11 Red Red Violet V5
5R12 Pachysandra
5R13 Celestial
5R16 Caribbean
5R17 Topaz

Roulette

5D29 Ocean
5D30 Taupe
5D31 Pewter
5D32 Sky
5D33 Cinnamon
5D34 Rosewood
5D35 Plum
5D36 Spearmint
5D37 Forest
5D38 Midnight

Spyder

5B00 Orchid
5B01 Foggy Night
5B04 Peri
5B05 Merlot
5B06 Dove
5B07 Sage
5B09 Topaz
5B10 Ocean
5B11 Currant
5B12 Lichen

Sweepstakes

5B80 Sky
5B81 Almond
5B82 Taupe
5B83 Charcoal
5B84 Nutmeg
5B85 Cinnamon
5B86 Currant
5B87 Opal
5B88 Plum
5B89 Midnight
5B90 Mist
5B91 Ocean
5B92 Forest

Price Group 3**Hampstead**

B351 Blue Green V4
B359 Blue Blue
Green V5
B361 Blue V3
(Low Intensity)
B363 Blue V4
B366 Blue Blue Violet V4
B369 Blue Blue Violet V5
B377 Violet V5
(Low Intensity)
B386 Red Red Violet V4
(Low Intensity)
B389 Red Red Violet V5
B395 Grey V5
B399 Black
B406 Windflower
B407 Twinflower
B408 Lupine
B409 Cornflower
B410 Aegean
B412 Starflower
B413 Shale
B415 Taupe
B416 Topaz
B417 Saddle
B418 Paprika
B419 Cinnamon
B420 Apple
B421 Leaf

Zoe

5A09 Apricot
5A10 Eggplant
5A11 Avocado
5A12 Cinnamon
5A14 Peacock
5A15 Rain
5A16 Grey Flannel
5A17 Ivory Cream
5A19 Currant

Leather Price Group

L107 Black
L202 Dusk
L203 Bottle
L207 Mahogany
L220 Soapstone
L221 Rocky
L224 Plum
L500 Camel
L503 Navy
L507 Vineyard

Designtex Graded-In Program

All Designtex Graded-In fabrics are now supported when ordered on Steelcase furniture. The Designtex Graded-In Program also includes the Environmental Impact Collection which offers sustainable textiles in affordable price groups. For additional information and fabric samples, contact your local Designtex sales representative at 1.800.221.1540.

Designtex upholsteries are graded into Steelcase Price Groups 2 through 10:

Price Group 2

Bee (Environmental Impact Collection)

- 5E44 Caspain
- 5E45 Chamois
- 5E46 Nutmeg
- 5E47 Java
- 5E48 Cinnamon
- 5E49 Laquer
- 5E50 Currant
- 5E51 Lupine
- 5E52 Prune
- 5E53 Aubergine
- 5E54 Sky
- 5E55 Cadet
- 5E56 Midnight
- 5E57 Khaki
- 5E58 Stem
- 5E59 Pine
- 5E60 Pond
- 5E61 Tuscan
- 5E62 Forest
- 5E63 Taupe
- 5E64 Pewter
- 5E65 Raven

Price Group 3

Lagoon (Environmental Impact Collection)

- 5D80 Pond
- 5D81 Chamois
- 5D82 Willow
- 5D83 Java
- 5D84 Nutmeg
- 5D85 Cinnamon
- 5D86 Currant
- 5D87 Opal
- 5D88 Crocus
- 5D89 Aubergine
- 5D90 Mist
- 5D91 Cadet
- 5D92 Midnight
- 5D93 Lichen
- 5D94 Spearmint
- 5D95 Forest
- 5D96 Sage
- 5D97 Charcoal
- 5D98 Raven

Prairie (Environmental Impact Collection)

- 5E66 Plum
- 5E67 Chamois
- 5E68 Pewter
- 5E69 Dark Taupe
- 5E70 Doe
- 5E71 Luggage
- 5E72 Java
- 5E73 Mandarin
- 5E74 Cinnabar
- 5E75 Currant
- 5E76 Watermelon
- 5E77 Lupine
- 5E78 Aubergine
- 5E79 Lichen
- 5E80 Stem
- 5E81 Forest
- 5E82 Sage
- 5E83 Ocean
- 5E84 Kale
- 5E85 Cadet
- 5E86 Sky
- 5E87 Midnight
- 5E88 Charcoal
- 5E89 Cinder
- 5E90 Raven

Reed Stripe (Environmental Impact Collection)

- 5D55 Java
- 5D56 Willow
- 5D57 Camel
- 5D58 Charcoal
- 5D59 Lichen
- 5D60 Pond
- 5D61 Cadet
- 5D62 Nutmeg
- 5D63 Paprika
- 5D64 Currant
- 5D65 Ocean
- 5D66 Midnight
- 5D67 Forest

Price Group 4

Bowline

- J568 Canyon
- J569 Beach
- J570 Paprika
- J571 Ocean
- J572 Leaf
- J573 Midnight
- J574 Smoke

Closed Loop

- J589 Sand
- J590 Taupe
- J591 Saffron
- J592 Redwood
- J593 Lapis
- J594 Indigo
- J595 Robin's Egg
- J596 Willow
- J597 Malachite
- J598 Forest
- J599 Jade
- J600 Mahogany
- J601 Amethyst
- J602 Tangerine
- J603 Mineral
- J604 Black

Cord

- J582 Canyon
- J583 Beach
- J584 Paprika
- J585 Ocean
- J586 Leaf
- J587 Midnight
- J588 Smoke

Croquet

- 5C54 Currant
- 5C55 Almond
- 5C56 Taupe
- 5C57 Charcoal
- 5C58 Camel
- 5C59 Lichen
- 5C60 Forest
- 5C61 Mist
- 5C62 Ocean
- 5C63 Sky
- 5C64 Cinnamon
- 5C65 Rosewood
- 5C66 Plum

Domino

- 5C34 Ocean
- 5C35 Camel
- 5C36 Charcoal
- 5C37 Pewter
- 5C38 Plum
- 5C39 Rosewood
- 5C40 Cinnamon
- 5C41 Sky
- 5C42 Midnight
- 5C43 Forest

Montezuma

- J335 Adobe
- J336 Jack Rabbit
- J337 Palomino
- J338 Tumbleweed
- J339 Citrus
- J340 Chili
- J341 Salsa
- J342 Cornflower
- J343 Azul
- J344 Lapis
- J345 Aqua
- J346 Peacock
- J347 Peyote

Nolita

- J605 Almond
- J606 Earth
- J607 Sesame
- J608 Sunflower
- J609 Cherry
- J610 Cobalt
- J611 Glacier
- J612 Clover
- J613 Spruce
- J614 Iris
- J615 Terracotta
- J616 Graphite
- J617 Carbon

Rook

- 5E34 Lichen
- 5E35 Almond
- 5E36 Camel
- 5E37 Pewter
- 5E38 Opal
- 5E39 Spearmint
- 5E40 Sky
- 5E41 Mandarin
- 5E42 Lupine
- 5E43 Cinnamon

Round About

- J575 Canyon
- J576 Beach
- J577 Paprika
- J578 Ocean
- J579 Leaf
- J580 Midnight
- J581 Smoke

Skittles

- 5D42 Ocean
- 5D43 Taupe
- 5D44 Camel
- 5D45 Nutmeg
- 5D46 Lichen
- 5D47 Sky
- 5D48 Charcoal
- 5D49 Plum
- 5D50 Paprika
- 5D51 Currant

Tango

- J081 Neutra
- J082 Deer
- J083 Elephant
- J084 Pascal
- J085 Borolo
- J086 Cosmos
- J087 Aegean
- J088 Ink
- J089 Aloe
- J090 Sherwood
- J091 Currant
- J092 Squash
- J093 Salt
- J094 Pepper

Tivoll

- 5C80 Spearmint
- 5C81 Camel
- 5C82 Almond
- 5C83 Pewter
- 5C84 Nutmeg
- 5C85 Cinnamon
- 5C86 Currant
- 5C87 Lichen
- 5C88 Plum
- 5C89 Sky

Vibe

- J548 Coconut
- J549 Sand
- J550 Malt
- J551 Root Beer
- J552 Champagne
- J553 Papaya
- J554 Cherry
- J555 Pool
- J556 Petal
- J557 Ocean
- J558 Slate
- J559 Key Lime
- J560 Palm Tree
- J561 Jam
- J562 Huckleberry
- J563 Sunrise
- J564 Snow Cone
- J565 Green Tea
- J566 Charcoal
- J567 Licorice

Wobble

- 5D16 Rosewood
- 5D17 Cinnamon
- 5D18 Paprika
- 5D19 Pewter
- 5D20 Camel
- 5D21 Lichen
- 5D22 Ocean
- 5D23 Sky
- 5D24 Plum
- 5D25 Midnight

Price Group 5**AbeX**

J424 Dust
 J425 Rust
 J426 Chili Sauce
 J427 Titanic
 J428 Jungle
 J429 Amazon
 J430 Grape Slush

Frisbee

5C67 Sage
 5C68 Chamois
 5C69 Camel
 5C70 Nutmeg
 5C71 Spearmint
 5C72 Ocean
 5C73 Lichen
 5C74 Sky
 5C75 Plum
 5C76 Midnight

Infield

5C44 Spearmint
 5C45 Almond
 5C46 Camel
 5C47 Taupe
 5C48 Cinnamon
 5C49 Currant
 5C50 Plum
 5C51 Forest
 5C52 Ocean
 5C53 Midnight

Retreat

5D68 Taupe
 5D69 Camel
 5D70 Charcoal
 5D71 Mist
 5D72 Violet
 5D73 Midnight
 5D74 Spearmint
 5D75 Lichen
 5D76 Forest
 5D77 Nutmeg
 5D78 Cinnamon
 5D79 Currant

Sam

J360 Pebble
 J361 Cornsilk
 J362 Yolk
 J363 Ladybug
 J364 Cherry
 J365 Sky
 J366 Bluejay
 J367 Grass
 J368 Sweetpea
 J369 Jam
 J370 Grape
 J371 Goldfish
 J372 River
 J373 Stone

Price Group 6**Rough & Ready**

J431 Wheat
 J432 Field
 J433 Sand
 J434 Squirrel
 J435 Mink
 J436 Sun
 J437 Lemon
 J438 Pepper
 J439 Wine
 J440 Ink
 J441 Octopus
 J442 Icy
 J443 Cobalt
 J444 Lagoon
 J445 Brook
 J446 Kale
 J447 Leaf
 J448 Sprout
 J449 Concord
 J450 Raisin
 J451 Tiger
 J452 Cinnamon

Price Group 7**Ace**

J502 Beige
 J503 Camel
 J504 Red
 J505 Orange
 J506 Black
 J507 Gray

Firefly

J250 Ash
 J251 Cashew
 J252 Currant
 J253 Firebee
 J254 Bleu
 J255 Riviera
 J256 Citrine
 J257 Verdant
 J258 Sherwood
 J259 Charcoal

Shimmy

J106 Wheat
 J107 Lark
 J108 Amber
 J109 Chili
 J110 Moroccan
 J111 Artichoke
 J112 Foliage
 J113 Mulberry
 J114 Canyon
 J115 Feather
 J116 Storm

Wool Suede Too

J457 Stone
 J458 Tan
 J459 Squash
 J460 Blush
 J461 Dust
 J462 Mineral
 J463 Sesame
 J464 Ginger
 J465 Eucalyptus
 J466 Patina
 J467 Green Tea
 J468 Pecan
 J469 China
 J470 Juniper
 J471 Olive
 J472 Persimmon
 J473 Charcoal
 J474 Ink
 J475 Jam
 J476 Cranberry
 J477 Shale
 J478 Black

Price Group 8**Coppice**

J374 Vanilla
 J375 Mushroom
 J376 Straw
 J377 Cardinal
 J378 Volcano
 J379 Cornflower
 J380 Marine
 J381 Larkspur
 J382 Regiment
 J383 Ivy
 J384 African Violet
 J385 Inca
 J386 Kangaroo
 J387 Gunmetal
 J388 Pewter

Delphos

J117 Silver Birch
 J118 Champagne
 J119 Amber
 J120 Cedar
 J121 Cranberry
 J122 Marina
 J123 Blue Spruce
 J124 Hyacinth
 J125 Cypress
 J126 Ultra Violet
 J127 Damson
 J128 Flat Iron

Falling Leaves

J314 Acorn
 J315 Barn
 J316 Spring
 J317 Forest
 J318 Meadow
 J319 Autumn

Furrows

J320 Vanilla
 J321 Mushroom
 J322 Koala
 J323 Straw
 J324 Cardinal
 J325 Volcano
 J326 Cornflower
 J327 Marine
 J328 Larkspur
 J329 Regiment
 J330 Ivy
 J331 African Violet
 J332 Inca
 J333 Kangaroo
 J334 Gunmetal

Lillian

J268 Silver Birch
 J269 Champagne
 J270 Butternut
 J271 Cedar
 J272 Marina
 J273 Blue Spruce
 J274 Hunter
 J275 Cypress
 J276 Hyacinth
 J277 Flat Iron

Loseta

J389 Straw
 J390 Persimmon
 J391 Cassis
 J392 Bluestone
 J393 Briar
 J394 Crocus
 J395 Shale
 J396 Cattail

Meander

J397 Mushroom
 J398 Straw
 J399 Volcano
 J400 Volcano Ivy
 J401 Marine
 J402 Larkspur
 J403 Regiment Volcano
 J404 Regiment
 J405 Ivy
 J406 Regiment Ivy
 J407 Violet Ivy
 J408 Inca Ivy
 J409 Kangaroo
 J410 Gunmetal
 J411 Pewter

Packard

J412 Porcelain
 J413 Loden
 J414 Camel
 J415 Brass
 J416 Pimpernel
 J417 Gemstone
 J418 Lapis
 J419 Leaf
 J420 Mint
 J421 Patina
 J422 Plum
 J423 Cricket

Rickshaw

J479 Driftwood
 J480 Ochre
 J481 Cherry
 J482 Midnight
 J483 Pistachio
 J484 Dusk
 J485 Paprika

Price Group 9**Gramercy**

J647 Fawn
 J648 Chocolate
 J649 Stag
 J650 Cordovan
 J651 Claret
 J652 Brook
 J653 Navy
 J654 Moss
 J655 Bottle
 J656 Hunter
 J657 Brick
 J658 Coal

NoMad

J486 Lager
 J487 Peaches-n-Cream
 J488 Tangerine
 J489 Green Mint
 J490 Limeade
 J491 Smudge
 J492 Sea Breeze
 J493 Ice Blast
 J494 Root Beer

Price Group 10**Plums**

J495 Fieldstone
 J496 Celery
 J497 Penny
 J498 Pond
 J499 Mulberry
 J500 Iris
 J501 Boysenberry

► See the *Surface Materials Reference Manual* for a listing of upholstery colors.

**Price Group
COM/COL
(Customer's Own
Material/Leather)**

**Fabric Approval and
Yardage**

To confirm whether a particular COM material has already been tested for use on a specific Steelcase product or to determine actual yardage requirements:

- Visit www.steelcase.com
- Click on "Knowledge & Design"
- Select "Customer's Own Material"

You can find the same information on the in2 site.

Follow these steps:

- Visit www.in2.steelcase.com
- Click on "Sales/Design Team"
- Select "Surface Materials"
- Select "Customer's Own Material"

For additional information regarding Customer's Own Material, call 1.888.STEELCASE.

Steelcase Classics Collection Upholstery Matrix

Steelcase
Classics Collection
Upholstery Matrix



	Ally 463 Series	Cachet 487 Series	Criterion 453 Series	Criterion Plus 453 Series	Drive 461 Series	Jersey Series	Leap 462 Series Standard	Leap 462 Series Pillow	Leap 462 Series HD Standard	Leap 462 Series HD Pillow	Leap 464 Series WorkLounge	Max-Stacker II 473 Series	Parade! 470 Series	Player 475 Series	Protegé 433 Series	Rally 457 Series	Sensor 458 Series	Snodgrass 474 Series	Think 465 Series
Classics Collection																			
Buzz2 Price Group 1	■	■	■	■	■	■	■	■	■	■	■	■	■	■	■	■	■	■	■
Canzoné Price Group 2	■	■	■	■	■	•	■	■	■	■	■	■	■	■	■	■	■	■	■
Cavalcade Price Group 2	■	■	■	■	■	•	■	■	■	■	■	■	■	■	■	■	■	■	■
Cricket Price Group 2	■	■	■	■	■	•	■	■	■	■	■	■	■	■	■	■	■	■	■
Hampstead Price Group 3	■	■	■	■	■	•	■	■	■	■	■	■	■	■	■	■	■	■	■
Jacks Price Group 1	■	■	■	■	■	•	■	■	■	■	■	■	■	■	■	■	■	■	■
Link Price Group 1	■	■	■	■	■	•	■	■	■	■	■	■	■	■	■	■	■	■	■
Regis Price Group 2	■	■	■	■	■	•	■	■	■	■	■	■	■	■	■	■	■	■	■
Roulette Price Group 2	■	■	■	■	■	•	■	■	■	■	■	■	■	■	■	■	■	■	■
Spyder Price Group 2	■	■	■	■	■	•	■	■	■	■	■	■	■	■	■	■	■	■	■
Sweepstakes Price Group 2	■	■	■	■	■	•	■	■	■	■	■	■	■	■	■	■	■	■	■
Leather Leather	■	■	•	■	■	•	■	■	■	■	•	•	•	•	■	■	□	■	■
Coach Leather	•	•	•	•	•	•	•	■	•	•	■	•	•	•	•	•	•	•	•
Seating Vinyl Price Group 1	■	■	■	■	•	•	■	■	■	■	•	•	•	■	•	•	•	■	■
Zoe Price Group 3	■	■	■	■	■	•	■	■	■	■	•	■	■	■	■	■	■	■	■
Other Upholstery																			
Jersey Mesh	•	•	•	•	•	■	•	•	•	•	•	•	•	•	•	•	•	•	•
Jersey Stretch Pullover	•	•	•	•	•	■	•	•	•	•	•	•	•	•	•	•	•	•	•
Think 3D Knit	•	•	•	•	•	•	•	•	•	•	•	•	•	•	•	•	•	•	■

Leap 464 Series WorkLounge is standard with Designtex Wool Suede Too.
Elmo Rustical leather and Coach leather are optional.

Jersey is available with black fabric or black leather seat. Buzz2 or COM may be specified as an option on fabric seat models. The back rest is standard with mesh (available in 8 colors) or with an optional stretch pullover (available in 6 colors).

▶ See page 283 for mesh and pullover colors.

Legend

- = Not available
- = Available
- = Available with exceptions
- ▶ See specification pages for details.

Designtex Graded-In Seating Upholstery Matrix

	Ally 463 Series	Cachet 487 Series	Criterion 453 Series	Criterion Plus 453 Series	Drive 461 Series	Jersey Series	Leap 462 Series Sewn	Leap 462 Series Pillow	Leap 462 Series HD Sewn	Leap 462 Series HD Pillow	Leap 464 Series WorkLounge	Max-Stacker II 473 Series	ParadeL 470 Series	Player 475 Series	Protege' 433 Series	Rally 457 Series	Sensor 458 Series	Snodgrass 474 Series	Think 465 Series
Environmental Impact Collection																			
Bee Price Group 2	■	■	■	■	■	•	■	■	■	■	•	■	■	■	■	■	■	■	■
Lagoon Price Group 3	■	■	■	■	■	•	■	■	■	■	•	■	■	■	■	■	■	■	■
Prairie Price Group 3	■	■	■	■	■	•	■	■	■	■	•	•	■	■	■	■	■	■	■
Reed Stripe Price Group 3	■	■	•	■	•	•	■	■	■	■	•	■	■	■	■	■	•	■	■
Other Seating Upholstery																			
Abex Price Group 5	■	•	■	■	•	•	■	■	■	■	•	■	■	■	■	■	■	■	■
Ace Price Group 7	■	•	■	■	■	•	■	■	■	■	•	■	■	■	■	■	•	■	■
Bowline Price Group 4	■	■	•	■	■	•	■	■	■	■	•	■	■	■	■	■	■	■	■
Closed Loop Price Group 4	■	•	■	■	■	•	■	■	■	■	•	■	■	■	■	■	■	■	■
Coppice Price Group 8	■	■	■	■	■	•	■	■	■	■	•	•	■	■	■	■	■	■	■
Cord Price Group 4	•	•	•	■	•	•	•	■	•	■	•	■	■	■	■	■	■	■	■
Croquet Price Group 4	■	■	•	■	•	•	■	■	■	■	•	•	■	•	•	•	•	■	■
Delphos Price Group 8	■	■	■	■	■	•	■	■	■	■	•	•	■	■	■	■	■	■	■
Domino Price Group 4	■	■	■	■	■	•	■	■	■	■	•	■	■	■	■	■	■	■	■
Falling Leaves Price Group 8	■	•	■	■	■	•	■	■	■	■	•	■	■	■	■	•	•	■	■
Firefly Price Group 7	■	•	■	■	•	•	■	■	■	■	•	■	■	■	•	•	•	■	■
Frisbee Price Group 5	■	■	•	•	■	•	•	■	•	■	•	•	•	■	■	■	•	■	■
Furrows Price Group 8	■	■	■	■	■	•	•	■	■	■	•	•	•	■	•	•	•	■	■
Gramercy Price Group 9	■	■	■	■	■	•	■	■	■	■	•	■	■	■	■	■	•	■	■
Infield Price Group 5	■	■	•	•	•	•	■	■	■	■	•	•	■	■	•	•	•	■	■
Lillian Price Group 8	■	■	■	■	■	•	■	■	■	■	•	■	■	■	■	■	■	■	■
Loseta Price Group 8	■	■	■	■	■	•	■	■	■	■	•	■	■	■	■	■	■	■	■
Meander Price Group 8	■	■	■	■	■	•	■	■	■	■	•	■	■	■	■	■	■	■	■
Montezuma Price Group 4	■	■	■	■	■	•	■	■	■	■	•	•	■	■	■	■	■	■	■
Nolita Price Group 4	•	•	•	■	■	•	•	■	•	■	•	■	■	■	■	•	•	■	■
NoMad Price Group 9	■	•	•	■	•	•	■	■	■	■	•	■	■	■	•	•	•	■	■
Packard Price Group 8	■	■	■	■	■	•	■	■	■	■	•	■	■	■	■	■	■	■	■
Plums Price Group 10	■	•	•	■	•	•	■	■	■	■	•	■	■	■	■	•	•	•	■
Retreat Price Group 5	■	■	■	■	■	•	■	■	■	■	•	■	■	■	■	■	■	■	■
Rickshaw Price Group 8	■	•	•	•	•	•	■	■	■	■	•	■	■	■	■	•	•	■	■
Rook Price Group 4	■	■	■	■	■	•	■	■	■	■	•	■	■	■	■	■	■	■	■
Rough & Ready Price Group 6	■	■	■	■	■	•	■	■	■	■	•	■	■	■	•	•	•	■	■
Round About Price Group 4	■	■	•	■	•	•	•	■	•	■	•	■	■	■	■	•	•	■	■
Sam Price Group 5	■	■	■	■	■	•	■	■	■	■	•	•	■	■	■	■	■	■	■
Shimmy Price Group 7	■	•	■	■	•	•	■	■	■	■	•	•	■	■	■	•	•	■	■
Skittles Price Group 4	■	■	■	■	■	•	■	■	■	■	•	■	■	■	■	■	■	■	■
Tango Price Group 4	■	■	■	■	■	•	■	■	■	■	•	■	■	■	■	■	■	■	■
Tivoli Price Group 4	■	■	•	•	■	•	■	■	■	■	•	•	■	■	■	■	•	■	■
Vibe Price Group 4	■	■	■	■	■	•	■	■	■	■	•	■	■	■	■	■	■	■	■
Wobble Price Group 4	■	■	•	■	•	•	■	■	■	■	•	•	■	•	•	•	■	■	■
Wool Suede Too Price Group 7	■	■	■	■	■	•	■	■	■	■	■	■	■	■	■	■	■	■	■

Legend

- = Not available
- = Available
- = Available with exceptions
- ▶ See specification pages for details.

Fire Code Seating Upholstery Matrix

Fire Code Seating (FCS) indicates that a product is constructed to meet the strict fire code requirements of high public occupancy areas.

The following matrix lists each seating line and denotes fabrics that are available, available with exceptions, and not available.

For further detail regarding exceptions, see the specific chapter within the *Seating Specification Guide* or the *Surface Materials Reference Manual*.

	Fabric Price Group	Ally 463 Series	Cachet 487 Series*	Criterion 453 Series**	Criterion Plus 453 Series	Drive 461 Series	Jersey Series	Leap 462 Series Standard	Leap 462 Series Pillow	Leap 462 Series HD Standard	Leap 462 Series HD Pillow	Max-Stacker 472 Series	Max-Stacker II 473 Series	Paradel 470 Series	Player 475 Series	Protégé 433 Series	Rally 457 Series	Sensor 458 Series***	Snodgrass 474 Series	Think 465 Series****	
Buzz2	1	•	•	□	•	•	•	•	•	•	•	•	•	•	•	•	•	•	•	•	•
Canzoné	2	•	■	□	•	■	•	•	•	•	•	•	•	•	■	■	■	□	□	•	•
Cavalcade	2	•	■	□	•	■	•	•	•	•	•	•	•	•	■	■	■	□	□	•	•
Cricket	2	•	•	□	•	•	•	■	•	•	•	•	•	•	•	•	•	•	•	•	•
Hampstead	3	■	■	□	■	•	•	■	■	•	•	•	•	•	•	•	■	■	□	□	•
Jacks	1	■	■	□	■	•	•	■	•	•	•	•	•	•	■	■	■	□	□	•	•
Link	1	■	■	□	■	•	•	■	•	•	•	•	•	•	■	■	■	□	□	•	•
Regis	2	■	■	□	•	■	•	•	•	•	•	•	•	•	■	■	■	□	□	•	•
Roulette	2	•	•	□	•	•	•	•	•	•	•	•	•	•	■	■	■	□	□	•	•
Seating Vinyl	1	•	•	•	•	•	•	•	•	•	•	•	•	•	■	•	•	•	■	•	•
Spyder	2	■	■	□	•	•	•	■	•	•	•	•	•	•	■	■	■	□	□	•	•
Sweepstakes	2	■	■	□	•	■	•	•	•	•	•	•	•	•	■	■	■	□	□	•	•
Zoe	3	•	•	□	•	•	•	•	•	•	•	•	•	•	■	■	■	□	□	•	•
Leather	Leather	■	•	•	•	■	•	■	■	•	•	•	•	•	•	■	■	□	■	•	•

*Cachet non-upholstered models and upholstered models only with certain fabric choices are available with FCS option.

**Criterion and Criterion fully upholstered models meet fire code requirements only when specified with the following:

- Adjustable seat depth and 6205 Black plastic.

***Sensor Size II adjustable-back models are available with FCS option in Hampstead and leather only.

****Think 465 is currently being tested for fabrics that pass FCS requirements.

Leap bare-back and bare-back vest models do not meet fire code requirements.

Legend

- = Not available
- = Available
- = Available with exceptions
- ▶ See specification pages for details.

Fire Code Seating Upholstery Matrix for Designtex

Designtex Graded-In

	Ally 463 Series	Cachet 487 Series	Criterion 453 Series	Criterion Plus 453 Series	Drive 461 Series	Jersey Series	Leap 462 Series Sewn	Leap 462 Series Pillow	Leap 462 Series HD Sewn	Leap 462 Series HD Pillow	Max-Stacker II 473 Series	Parade! 470 Series	Player 475 Series	Protege' 433 Series	Rally 457 Series	Sensor 458 Series	Snodgrass 474 Series	Think 465 Series*
Environmental Impact Collection																		
Bee Price Group 2	•	•	□	•	•	•	■	•	•	•	•	•	•	•	•	•	□	•
Lagoon Price Group 3	■	•	□	•	•	•	■	•	•	•	•	•	■	•	•	•	□	•
Prairie Price Group 3	■	•	□	•	•	•	•	•	•	•	•	•	■	•	•	•	□	•
Reed Stripe Price Group 3	■	•	•	•	•	•	■	•	•	•	•	•	■	•	•	•	□	•
Other Seating Upholstery																		
Abex Price Group 5	•	•	•	•	•	•	•	•	•	•	•	•	•	•	•	•	•	•
Ace Price Group 7	•	•	•	•	•	•	•	•	•	•	•	•	•	•	•	•	•	•
Bowline Price Group 4	•	•	•	•	•	•	•	•	•	•	•	•	•	•	•	•	•	•
Closed Loop Price Group 4	■	•	•	•	•	•	•	•	•	•	•	•	■	•	•	•	□	•
Coppice Price Group 8	•	•	•	•	•	•	•	•	•	•	•	•	•	•	•	•	•	•
Cord Price Group 4	•	•	•	•	•	•	•	•	•	•	•	•	•	•	•	•	•	•
Croquet Price Group 4	•	•	•	•	•	•	■	•	•	•	•	•	•	•	•	•	•	•
Delphos Price Group 8	•	•	•	•	•	•	•	•	•	•	•	•	•	•	•	•	•	•
Domino Price Group 4	■	•	□	•	•	•	■	•	•	•	•	•	■	•	•	•	□	•
Falling Leaves Price Group 8	•	•	•	•	•	•	•	•	•	•	•	•	•	•	•	•	•	•
Firefly Price Group 7	•	•	•	•	•	•	•	•	•	•	•	•	•	•	•	•	•	•
Frisbee Price Group 5	•	•	•	•	•	•	•	•	•	•	•	•	•	•	•	•	•	•
Furrows Price Group 8	•	•	•	•	•	•	•	•	•	•	•	•	•	•	•	•	•	•
Gramercy Price Group 9	•	■	□	•	■	•	■	•	•	•	•	•	■	•	•	•	■	•
Infield Price Group 5	■	•	•	•	•	•	•	•	•	•	•	•	■	•	•	•	□	•
Lillian Price Group 8	•	•	•	•	•	•	•	•	•	•	•	•	•	•	•	•	•	•
Loseta Price Group 8	•	•	•	•	•	•	•	•	•	•	•	•	•	•	•	•	•	•
Meander Price Group 8	■	■	•	•	■	•	■	•	•	•	•	•	■	■	■	□	■	•
Montezuma Price Group 4	■	■	□	•	■	•	•	•	•	•	•	•	■	■	■	□	■	•
Nolita Price Group 4	•	•	•	•	•	•	•	•	•	•	•	•	•	•	•	•	•	•
NoMad Price Group 9	•	•	•	•	•	•	•	•	•	•	•	•	•	•	•	•	•	•
Packard Price Group 8	■	■	•	•	■	•	■	•	•	•	•	•	■	■	■	□	■	•
Plums Price Group 10	•	•	•	•	•	•	•	•	•	•	•	•	•	•	•	•	•	•
Retreat Price Group 5	•	•	□	•	•	•	•	•	•	•	•	•	•	•	•	•	•	•
Rickshaw Price Group 8	•	•	•	•	•	•	•	•	•	•	•	•	•	•	•	•	•	•
Rook Price Group 4	•	•	•	•	•	•	•	•	•	•	•	•	•	•	•	•	•	•
Rough & Ready Price Group 6	•	•	•	•	•	•	•	•	•	•	•	•	•	•	•	•	•	•
Round About Price Group 4	•	•	•	•	•	•	•	•	•	•	•	•	•	•	•	•	•	•
Sam Price Group 5	•	•	•	•	•	•	•	•	•	•	•	•	•	•	•	•	•	•
Shimmy Price Group 7	•	•	•	•	•	•	•	•	•	•	•	•	•	•	•	•	•	•
Skittles Price Group 4	•	•	□	•	•	•	•	•	•	•	•	•	■	■	■	□	□	•
Tango Price Group 4	■	•	□	•	•	•	•	•	•	•	•	•	■	•	•	•	□	•
Tivoli Price Group 4	•	•	•	•	•	•	•	•	•	•	•	•	•	•	•	•	•	•
Vibe Price Group 4	■	•	•	•	•	•	•	•	•	•	•	•	■	•	•	•	□	•
Wobble Price Group 4	•	•	•	•	•	•	•	•	•	•	•	•	•	•	•	•	•	•
Wool Suede Too Price Group 7	■	■	□	•	■	•	■	■	•	•	•	•	■	■	■	□	■	•

*Think 465 is currently being tested for fabrics that pass FCS requirements.

Legend

- = Not available
- = Available
- = Available with exceptions
- ▶ See specification pages for details.

Exceptions: Leap bare-back models and bare-back vest models do not meet fire code requirements. Criterion meets fire code requirements only when specified with the following: Adjustable seat depth and 6205 Black plastic. Criterion fully upholstered model is also available in FCS with options specified above.

Color Availability Matrix

Legend

- = Not available
- = Available
- = Available with exceptions
- ▶ See specification pages for details.

		Plastic										Metal	Paint		Seating Coating					
		6205	6206	6250	6256	6259	6268	6296	6301	6302	6303	6421	6694	8046	9201	4799	7209	7000	7005	7011
		Black	Burgundy	Coffee	Graphite	Midnight	Navy	Sterling	Aegean	Baltic	Pomegranate	Ash	Slate	Polished Aluminum	Polished Chrome	Platinum Metallic	Black Texture	Black	Coffee	Graphite
Ally 463 Series	Outer seat, back, and arms	■	•	•	•	■	•	•	•	•	•	•	•	•	•	•	•	•	•	•
	Frame	■	•	•	•	■	•	■	•	•	•	•	•	•	•	•	•	•	•	•
Cachet 487 Series		■	•	•	•	■	•	•	•	•	•	■	•	•	•	•	•	•	•	•
Criterion 453 Series	Base, arms, outer seat and back, casters	■	•	■	■	•	•	•	•	•	•	•	•	•	•	•	•	•	•	•
	Foot ring	■	•	■	■	•	•	•	•	•	•	•	•	•	■	•	•	•	•	•
Drive 461 Series	Base, arms, faceplate, outer seat and back, casters	■	•	•	■	•	•	•	•	•	•	•	•	•	•	•	•	•	•	•
Jersey Series	Work chair	■	•	•	•	•	•	•	•	•	•	•	•	•	•	■	•	•	•	•
	Guest chair	•	•	•	•	•	•	•	•	•	•	•	•	•	•	■	■	•	•	•
Leap 462 Series	Base, outer seat and back foot ring	■	•	•	•	■	•	■	•	•	•	•	•	■	•	•	•	•	•	•
	Arms	■	•	•	•	•	•	•	•	•	•	•	•	•	•	•	•	•	•	•
Leap 462 Series HD	Base, outer seat and back	■	•	•	•	•	•	■	•	•	•	•	•	•	•	•	•	•	•	•
	Arms	■	•	•	•	•	•	•	•	•	•	•	•	•	•	•	•	•	•	•
Leap 464 Series WorkLounge	Backframe, arm supports, and base	•	•	•	•	•	•	•	•	•	•	•	•	■	•	•	•	•	•	•
Max-Stacker 472 and 473 Series	Frame and bookrack	•	•	•	•	•	•	•	•	•	•	•	•	•	■	•	•	■	■	■
	Seat and back	■	■	■	■	•	■	•	■	■	■	•	•	•	•	•	•	•	•	•
	Tablet arm	•	•	•	•	•	•	•	•	•	•	•	•	•	•	•	•	•	•	•
Parade! 470 Series	Frame	•	•	•	•	•	•	•	•	•	•	•	•	•	■	•	•	■	■	■
	Seat and back	■	■	■	■	•	■	•	■	■	■	•	•	•	•	•	•	•	•	•
	Arm caps	■	■	■	■	•	•	•	■	■	■	•	•	•	•	•	•	•	•	•
Player 475 Series	Frame on chairs with smooth arms	■	•	■	■	•	•	•	•	•	•	•	•	•	•	•	•	•	•	•
	Smooth arms	■	•	■	■	•	•	•	•	•	•	•	•	•	•	•	•	•	•	•
	Frame on chairs with textured arms	■	•	•	■	•	•	•	•	•	•	•	•	•	•	•	•	•	•	•
	Textured arms	■	•	•	■	•	•	•	•	•	•	•	•	•	•	•	•	•	•	•
	Tablet arm	•	•	•	•	•	•	•	•	•	•	•	•	•	•	•	•	•	•	•
Protegé 433 Series	Base, arms, arm caps, outer back, sled base, and casters	■	•	■	■	•	•	•	•	•	•	•	•	•	•	•	•	•	•	•
Rally 457 Series	Base, arms, outer seat and back, casters	■	•	■	■	•	•	•	•	•	•	•	•	•	•	•	•	•	•	•
Sensor 458 Series	Base, arms, outer seat and back, foot ring, casters	■	•	■	■	•	•	•	•	•	•	•	•	•	•	•	•	•	•	•
	Sled base	■	•	■	■	•	•	•	•	•	•	•	•	•	•	•	•	•	•	•
Snodgrass 474 Series	Frame	■	•	■	■	•	•	•	•	•	•	•	•	■	•	•	•	•	•	•
Think 465 Series	Base	■	•	•	•	•	•	•	•	•	•	•	■	■	•	•	•	•	•	•
	Back frame, arm supports, seat shell	■	•	•	•	•	•	•	•	•	•	•	■	•	•	•	•	•	•	•
	Arm caps, headrest, controls, casters	■	•	•	•	•	•	•	•	•	•	•	•	•	•	•	•	•	•	•

Laminate	
2412	Natural Cherry
2421	Medium Cherry
2511	Winter on Maple
2632	Medium Oak
2711	Natural Walnut
2722	Cream
2746	Black
2759	Warm White
2771	Medium Mahogany on Walnut
2810	Dawn
2811	Mist
Wood ▶ See page 282.	

Special Features

This chart provides general guidelines about some of the types of special features that are available.

	Different fabric on seat and back	Headrest	Sewn seam using vinyl or leather	Thicker seat cushion	Special seat height *	Special seat height base assemblies for field installation	Stool base	Jury base	Glides	Braking or reverse braking casters	High-performance arm	Oversized tablet arm	Corporate logo
Allly 463 Series	■	•	S	•	•	•	•	S	•	•	•	•	•
Cachet 487 Series	■	•	•	•	■	■	■	■	■	■	•	•	•
Criterion 453 Series	■	•	■	■	■	■	S	•	S	■	S	•	•
Drive 461 Series	■	•	•	•	■	■	■	•	■	■	S	•	•
Jersey Series	•	•	•	•	■	■	•	•	■	■	S	•	•
Leap 462 Series	■	■	S	■	■	■	S	■	■	■	S	•	■
Leap 464 Series WorkLounge	■	S	•	•	■	■	•	•	S	■	■	•	•
Max-Stacker 472 and Max-Stacker II 473 Series	•	•	•	•	•	•	•	•	S	•	•	■	•
Parade! 470 Series	•	•	•	•	•	•	•	•	S	•	•	•	•
Player 475 Series	■	•	•	S	•	•	•	•	S	•	•	•	•
Protégé 433 Series	•	•	•	•	■	■	■	•	■	■	•	•	•
Rally 457 Series	•	•	•	•	■	■	■	•	■	■	•	•	•
Sensor 458 Series	•	•	■	•	■	■	S	•	■	■	S	•	•
Snodgrass 474 Series	■	•	•	•	•	•	•	•	S	•	•	•	•
Think 465 Series	■	S	S	•	■	■	■	■	■	■	S	•	■

For individual quote information, or special requests not listed above, please submit an RFQ request form.

The form may be accessed at the following URL: <http://in2.steelcase.com/specialsrfq/>

*Maximum seat height is 33".

Minimum seat height is 14½" with 3" travel.

Legend

- = Not available
- = Available
- S = Standard offering
- ▶ See specification pages for details.

Resources

Style Number Index

296

Style Number Index

Style Number	Page	Description
4331203	175	Protegé 433 Work Chr
4331213	175	Protegé 433 Work Chr
4331223	175	Protegé 433 Work Chr
4331403	175	Protegé 433 Work Chr
4331413	175	Protegé 433 Work Chr
4331423	175	Protegé 433 Work Chr
4333003	177	Protegé 433 Guest Chr
4333013	177	Protegé 433 Guest Chr
4333023	177	Protegé 433 Guest Chr
4335013	178	Protegé 433 Sled-Base Guest Chr
4335023	178	Protegé 433 Sled-Base Guest Chr
4535300	81	Criterion 453 MidBk Work Chr
4535300D	81	Criterion 453 MidBk Work Chr
4535301	79	Criterion 453 HiBk Work Chr
4535301D	79	Criterion 453 HiBk Work Chr
4535310	81	Criterion 453 MidBk Work Chr
4535310D	81	Criterion 453 MidBk Work Chr
4535310DH	81	Criterion 453 MidBk Work Chr
4535310DW	81	Criterion 453 MidBk Work Chr
4535310H	81	Criterion 453 MidBk Work Chr
4535310W	81	Criterion 453 MidBk Work Chr
4535311	79	Criterion 453 HiBk Work Chr
4535311D	79	Criterion 453 HiBk Work Chr
4535311DH	79	Criterion 453 HiBk Work Chr
4535311DW	79	Criterion 453 HiBk Work Chr
4535311H	79	Criterion 453 HiBk Work Chr
4535311W	79	Criterion 453 HiBk Work Chr
4535330	81	Criterion 453 MidBk Work Chr
4535330D	81	Criterion 453 MidBk Work Chr
4535330DH	81	Criterion 453 MidBk Work Chr
4535330DP	80	Criterion 453 MidBk Work Chr
4535330DW	81	Criterion 453 MidBk Work Chr
4535330H	81	Criterion 453 MidBk Work Chr
4535330P	80	Criterion 453 MidBk Work Chr
4535330W	81	Criterion 453 MidBk Work Chr
4535331	79	Criterion 453 HiBk Work Chr
4535331D	79	Criterion 453 HiBk Work Chr
4535331DH	79	Criterion 453 HiBk Work Chr
4535331DP	78	Criterion 453 HiBk Work Chr
4535331DW	79	Criterion 453 HiBk Work Chr
4535331H	79	Criterion 453 HiBk Work Chr
4535331P	78	Criterion 453 HiBk Work Chr
4535331W	79	Criterion 453 HiBk Work Chr
4537300	85	Criterion 453 MidBk Stool
4537300D	85	Criterion 453 MidBk Stool
4537301	83	Criterion 453 HiBk Stool
4537301D	83	Criterion 453 HiBk Stool
4537310	85	Criterion 453 MidBk Stool
4537310D	85	Criterion 453 MidBk Stool
4537310DH	85	Criterion 453 MidBk Stool
4537310H	85	Criterion 453 MidBk Stool
4537310W	85	Criterion 453 MidBk Stool
4537311	83	Criterion 453 HiBk Stool
4537311D	83	Criterion 453 HiBk Stool

Style Number	Page	Description
4537311DH	83	Criterion 453 HiBk Stool
4537311DW	83	Criterion 453 HiBk Stool
4537311H	83	Criterion 453 HiBk Stool
4537311W	83	Criterion 453 HiBk Stool
4537330	85	Criterion 453 MidBk Stool
4537330D	85	Criterion 453 MidBk Stool
4537330DH	85	Criterion 453 MidBk Stool
4537330DP	84	Criterion 453 MidBk Stool
4537330DW	85	Criterion 453 MidBk Stool
4537330H	85	Criterion 453 MidBk Stool
4537330P	84	Criterion 453 MidBk Stool
4537330W	85	Criterion 453 MidBk Stool
4537331	83	Criterion 453 HiBk Stool
4537331D	83	Criterion 453 HiBk Stool
4537331DH	83	Criterion 453 HiBk Stool
4537331DP	82	Criterion 453 HiBk Stool
4537331DW	83	Criterion 453 HiBk Stool
4537331H	83	Criterion 453 HiBk Stool
4537331P	82	Criterion 453 HiBk Stool
4537331W	83	Criterion 453 HiBk Stool
4539301B	87	Criterion Plus 453 HiBk Work Chair
4539311B	87	Criterion Plus 453 HiBk Work Chair
4539311BH	87	Criterion Plus 453 HiBk Work Chair
4539311BW	87	Criterion Plus 453 HiBk Work Chair
4539331B	87	Criterion Plus 453 HiBk Work Chair
4539331BH	87	Criterion Plus 453 HiBk Work Chair
4539331BW	87	Criterion Plus 453 HiBk Work Chair
4571203	165	Rally 457 Work Chr
4571204	165	Rally 457 Work Chr
4571223	165	Rally 457 Work Chr
4571224	165	Rally 457 Work Chr
4571403	165	Rally 457 Work Chr
4571404	165	Rally 457 Work Chr
4571423	165	Rally 457 Work Chr
4571424	165	Rally 457 Work Chr
4573003	167	Rally 457 MidBk Guest Chr
4573023	167	Rally 457 MidBk Guest Chr
4575023	167	Rally 457 MidBk Guest Chr
4581203	153	Sensor 458 Sz II MidBk Work Chr
4581204	151	Sensor 458 Sz II HiBk Work Chr
4581206	149	Sensor 458 Sz II Adj-Bk Work Chr
4581223	153	Sensor 458 Sz II MidBk Work Chr
4581224	151	Sensor 458 Sz II HiBk Work Chr
4581226	148	Sensor 458 Sz II Adj-Bk Work Chr
4581227	147	Sensor 458 Sz II Adj HiBk Work Chr
4581233W	153	Sensor 458 Sz II MidBk Work Chr
4581234W	151	Sensor 458 Sz II HiBk Work Chr
4581236W	148	Sensor 458 Sz II Adj-Bk Work Chr
4581237W	147	Sensor 458 Sz II Adj HiBk Work Chr
4581403	153	Sensor 458 Sz II MidBk Work Chr
4581404	151	Sensor 458 Sz II HiBk Work Chr
4581406	149	Sensor 458 Sz II Adj-Bk Work Chr
4581423	153	Sensor 458 Sz II MidBk Work Chr
4581424	151	Sensor 458 Sz II HiBk Work Chr
4581426	148	Sensor 458 Sz II Adj-Bk Work Chr

Style Number	Page	Description	Style Number	Page	Description
4581427	147	Sensor 458 Sz II Adj HiBk Work Chr	46213049	43	Leap 462 Ribbon Bkframe Work Chr
4581433W	153	Sensor 458 Sz II MidBk Work Chr	46213059	43	Leap 462 Ribbon Bkframe Work Chr
4581434W	151	Sensor 458 Sz II HiBk Work Chr	46213129	39	Leap 462 Ribbon Bkframe Work Chr
4581436W	148	Sensor 458 Sz II Adj-Bk Work Chr	46213139	39	Leap 462 Ribbon Bkframe Work Chr
4581437W	147	Sensor 458 Sz II Adj HiBk Work Chr	46213149	43	Leap 462 Ribbon Bkframe Work Chr
4585023	154	Sensor 458 Sz II MidBk Sled Guest Chr	46213159	43	Leap 462 Ribbon Bkframe Work Chr
4585093	154	Sensor 458 Sz II MidBk Sled Guest Chr	46214029	39	Leap 462 Ribbon Bkframe Work Chr
4588201	157	Sensor 458 Sz I MidBk High Stil	46214039	39	Leap 462 Ribbon Bkframe Work Chr
4588221	157	Sensor 458 Sz I MidBk High Stil	46214049	43	Leap 462 Ribbon Bkframe Work Chr
4588231W	157	Sensor 458 Sz I MidBk High Stil	46214059	43	Leap 462 Ribbon Bkframe Work Chr
4588401	157	Sensor 458 Sz I MidBk High Stil	46214129	39	Leap 462 Ribbon Bkframe Work Chr
4588421	157	Sensor 458 Sz I MidBk High Stil	46214139	39	Leap 462 Ribbon Bkframe Work Chr
4588431W	157	Sensor 458 Sz I MidBk High Stil	46214149	43	Leap 462 Ribbon Bkframe Work Chr
4611100	123	Drive 461 Work Chr	46214159	43	Leap 462 Ribbon Bkframe Work Chr
4611101	123	Drive 461 Work Chr	4627100	59	Leap 462 Arch Backframe Stool
4611110	123	Drive 461 Work Chr	46271009	45	Leap 462 Ribbon Bkframe Stool
4611111	123	Drive 461 Work Chr	46271049	49	Leap 462 Ribbon Bkframe Stool
4611200	123	Drive 461 Work Chr	4627110	59	Leap 462 Arch Backframe Stool
4611201	123	Drive 461 Work Chr	46271109	45	Leap 462 Ribbon Bkframe Stool
4611210	123	Drive 461 Work Chr	46271149	49	Leap 462 Ribbon Bkframe Stool
4611211	123	Drive 461 Work Chr	4627200	59	Leap 462 Arch Backframe Stool
4611300	123	Drive 461 Work Chr	46272009	45	Leap 462 Ribbon Bkframe Stool
4611301	123	Drive 461 Work Chr	46272049	49	Leap 462 Ribbon Bkframe Stool
4611310	123	Drive 461 Work Chr	4627210	59	Leap 462 Arch Backframe Stool
4611311	123	Drive 461 Work Chr	46272109	45	Leap 462 Ribbon Bkframe Stool
4611400	123	Drive 461 Work Chr	46272149	49	Leap 462 Ribbon Bkframe Stool
4611401	123	Drive 461 Work Chr	46273029	47	Leap 462 Ribbon Bkframe Stool
4611410	123	Drive 461 Work Chr	46273049	51	Leap 462 Ribbon Bkframe Stool
4611411	123	Drive 461 Work Chr	46273129	47	Leap 462 Ribbon Bkframe Stool
4621100	57	Leap 462 Arch Bkframe Work Chr	46273149	51	Leap 462 Ribbon Bkframe Stool
46211009	37	Leap 462 Ribbon Bkframe Work Chr	46274029	47	Leap 462 Ribbon Bkframe Stool
4621101	57	Leap 462 Arch Bkframe Work Chr	46274049	51	Leap 462 Ribbon Bkframe Stool
46211019	37	Leap 462 Ribbon Bkframe Work Chr	46274129	47	Leap 462 Ribbon Bkframe Stool
46211049	41	Leap 462 Ribbon Bkframe Work Chr	46274149	51	Leap 462 Ribbon Bkframe Stool
46211059	41	Leap 462 Ribbon Bkframe Work Chr	462COACH1	34	Leap 462 Coach Ribbon Bkframe
4621110	57	Leap 462 Arch Bkframe Work Chr	462COACH2	34	Leap 462 Coach Ribbon Bkframe
46211109	37	Leap 462 Ribbon Bkframe Work Chr	462COACH3	34	Leap 462 Coach Ribbon Bkframe
4621111	57	Leap 462 Arch Bkframe Work Chr	462COACH4	34	Leap 462 Coach Ribbon Bkframe
46211119	37	Leap 462 Ribbon Bkframe Work Chr	462LEAP19L	29	Leap 462 Value Pkg Ribbon Bkframe Chr
46211149	41	Leap 462 Ribbon Bkframe Work Chr	462LEAP19LX	29	Leap 462 Value Pkg Ribbon Bkframe Chr
46211159	41	Leap 462 Ribbon Bkframe Work Chr	462LEAP1L	33	Leap 462 Value Pkg Arch Bkframe Chr
4621200	57	Leap 462 Arch Bkframe Work Chr	462LEAP1LX	33	Leap 462 Value Pkg Arch Bkframe Chr
46212009	37	Leap 462 Ribbon Bkframe Work Chr	462LEAP9L	29	Leap 462 Value Pkg Ribbon Bkframe Chr
4621201	57	Leap 462 Arch Bkframe Work Chr	462LEAP9LX	29	Leap 462 Value Pkg Ribbon Bkframe Chr
46212019	37	Leap 462 Ribbon Bkframe Work Chr	462LEAPHD1	201	Leap 462 Series HD Work Chair
46212049	41	Leap 462 Ribbon Bkframe Work Chr	462LEAPHD2	203	Leap 462 Series HD Work Chair
46212059	41	Leap 462 Ribbon Bkframe Work Chr	462LEAPHD3	205	Leap 462 Series HD Work Chair
4621210	57	Leap 462 Arch Bkframe Work Chr	462LEAPHD4	207	Leap 462 Series HD Work Chair
46212109	37	Leap 462 Ribbon Bkframe	462LEAPL	33	Leap 462 Value Pkg Arch Bkframe Chr
4621211	57	Leap 462 Arch Bkframe Work Chr	462LEAPLX	33	Leap 462 Value Pkg Arch Bkframe Chr
46212119	37	Leap 462 Ribbon Bkframe Work Chr	462LEAPP19L	31	Leap 462 Value Pkg Ribbon Bkframe Chr
46212149	41	Leap 462 Ribbon Bkframe Work Chr	462LEAPP9L	31	Leap 462 Value Pkg Ribbon Bkframe Chr
46212159	41	Leap 462 Ribbon Bkframe Work Chr	462PFB	53	Leap 462 Pillowed Upholstery Pkg
46213029	39	Leap 462 Ribbon Bkframe Work Chr	462PHB	53	Leap 462 Pillowed Upholstery Pkg
46213039	39	Leap 462 Ribbon Bkframe Work Chr	462PLWHD	217	Leap 462 Ser HD Pillowed Uph Pkg

Style Number Index, continued

Style Number	Page	Description
462PLWSTHD	216	Leap 462 Ser HD Pillowed Uph Pkg
462PST	54	Leap 462 Pillowed Upholstery Pkg
462PSTFB	52	Leap 462 Pillowed Upholstery Pkg
462PSTHB	52	Leap 462 Pillowed Upholstery Pkg
462PSTHD	218	Leap 462 Ser HD Pillowed Uph Pkg
462STLHD1	209	Leap 462 Series HD Stool
462STLHD2	211	Leap 462 Series HD Stool
462STLHD3	213	Leap 462 Series HD Stool
462STLHD4	215	Leap 462 Series HD Stool
462VESTHD	219	Leap 462 Series HD Vest Pkg
462VFB	55	Leap 462 Vest Package
462VHB	55	Leap 462 Vest Package
463480	226	Ally 463 Sled-Base Multi-Purp Chr
463482	226	Ally 463 Sled-Base Multi-Purp Chr
464COACHL	68	Leap 464 WorkLounge
464COACHO	69	Leap 464 Ottoman
464LOUNGE	66	Leap 464 WorkLounge
464OTTOMAN	67	Leap 464 Ottoman
46510000	110	Think 465 Work Chr
46510001	110	Think 465 Work Chr
46510010	111	Think 465 Work Chr
46510011	111	Think 465 Work Chr
46510100	102	Think 465 Work Chr
46510101	102	Think 465 Work Chr
46510110	103	Think 465 Work Chr
46510111	103	Think 465 Work Chr
46511000	112	Think 465 Work Chr
46511001	112	Think 465 Work Chr
46511010	113	Think 465 Work Chr
46511011	113	Think 465 Work Chr
46511100	104	Think 465 Work Chr
46511101	104	Think 465 Work Chr
46511110	105	Think 465 Work Chr
46511111	105	Think 465 Work Chr
46512000	108	Think 465 Work Chr
46512001	108	Think 465 Work Chr
46512010	109	Think 465 Work Chr
46512011	109	Think 465 Work Chr
46512100	100	Think 465 Work Chr
46512101	100	Think 465 Work Chr
46512110	101	Think 465 Work Chr
46512111	101	Think 465 Work Chr
46513000	106	Think 465 Work Chr
46513001	106	Think 465 Work Chr
46513010	107	Think 465 Work Chr
46513011	107	Think 465 Work Chr
46513100	98	Think 465 Work Chr
46513101	98	Think 465 Work Chr
46513110	99	Think 465 Work Chr
46513111	99	Think 465 Work Chr
46520000	111	Think 465 Work Chr
46520001	111	Think 465 Work Chr
46520010	111	Think 465 Work Chr
46520011	111	Think 465 Work Chr
46520100	103	Think 465 Work Chr

Style Number	Page	Description
46520101	103	Think 465 Work Chr
46520110	103	Think 465 Work Chr
46520111	103	Think 465 Work Chr
46521000	113	Think 465 Work Chr
46521001	113	Think 465 Work Chr
46521010	113	Think 465 Work Chr
46521011	113	Think 465 Work Chr
46521100	105	Think 465 Work Chr
46521101	105	Think 465 Work Chr
46521110	105	Think 465 Work Chr
46521111	105	Think 465 Work Chr
46522000	109	Think 465 Work Chr
46522001	109	Think 465 Work Chr
46522010	109	Think 465 Work Chr
46522011	109	Think 465 Work Chr
46522100	101	Think 465 Work Chr
46522101	101	Think 465 Work Chr
46522110	101	Think 465 Work Chr
46522111	101	Think 465 Work Chr
46523000	107	Think 465 Work Chr
46523001	107	Think 465 Work Chr
46523010	107	Think 465 Work Chr
46523011	107	Think 465 Work Chr
46523100	99	Think 465 Work Chr
46523101	99	Think 465 Work Chr
46523110	99	Think 465 Work Chr
46523111	99	Think 465 Work Chr
465THINK	97	Think 465 Design Pkg Work Chr
465THINKS4U	96	Think 465 Design Pkg Work Chr
470412	258	Parade 470 Stackable Seating
470412N	258	Parade 470 Stackable Seating
470419	258	Parade 470 Stackable Seating
470419N	258	Parade 470 Stackable Seating
470D	259	Parade 470 Transport/Strg Dolly
470G	259	Parade 470 Alignment Device
472410	267	Max-Stkr 472 Stackable Seating
472410BR	267	Max-Stkr 472 Stackable Seating
472410N	267	Max-Stkr 472 Stackable Seating
472410NBR	267	Max-Stkr 472 Stackable Seating
472410NTL	267	Max-Stkr 472 Stackable Seating
472410NTLB	267	Max-Stkr 472 Stackable Seating
472410NTR	267	Max-Stkr 472 Stackable Seating
472410NTRB	267	Max-Stkr 472 Stackable Seating
472410TL	267	Max-Stkr 472 Stackable Seating
472410TLB	267	Max-Stkr 472 Stackable Seating
472410TR	267	Max-Stkr 472 Stackable Seating
472410TRB	267	Max-Stkr 472 Stackable Seating
472BR	268	Max-Stkr 472 Bkrack Assy
472G	268	Max-Stkr 472 Alignment Device
472TAL	268	Max-Stkr 472 Tablet Arm Assy
472TAR	268	Max-Stkr 472 Tablet Arm Assy
473410	277	Max-Stkr II 473 Stackable Seating
473410B	277	Max-Stkr II 473 Stackable Seating
473410N	277	Max-Stkr II 473 Stackable Seating
473410NB	277	Max-Stkr II 473 Stackable Seating

Style Number	Page	Description	Style Number	Page	Description
473410NTL	277	Max-Stkr II 473 Stackable Seating	4878100	187	Cachet 487 Leg-Base Multi-Purp Chr
473410NTLB	277	Max-Stkr II 473 Stackable Seating	4878110	187	Cachet 487 Leg-Base Multi-Purp Chr
473410NTR	277	Max-Stkr II 473 Stackable Seating	4878200	187	Cachet 487 Leg-Base Multi-Purp Chr
473410NTRB	277	Max-Stkr II 473 Stackable Seating	4878201	187	Cachet 487 Leg-Base Multi-Purp Chr
473410TL	277	Max-Stkr II 473 Stackable Seating	4878210	187	Cachet 487 Leg-Base Multi-Purp Chr
473410TLB	277	Max-Stkr II 473 Stackable Seating	4878211	187	Cachet 487 Leg-Base Multi-Purp Chr
473410TR	277	Max-Stkr II 473 Stackable Seating	487BK	189	Cachet 487 Cushion Upholstery Pkg
473410TRB	277	Max-Stkr II 473 Stackable Seating	487D	191	Cachet 487 Transport/Strg Dolly
473B	278	Max-Stkr II 473 Bkrack Assy	487G	191	Cachet 487Ganging/Alignment Device
473D	269, 279	Max-Stkr II 473 Trans/Strg Dolly	487ST	190	Cachet 487 Cushion Upholstery Pkg
473G	278	Max-Stkr II 473 Alignment Device	487STBK	188	Cachet 487 Cushion Upholstery Pkg
473TL	278	Max-Stkr II 473 Tablet Arm Assy	TS38301	132	Jersey Chair
473TR	278	Max-Stkr II 473 Tablet Arm Assy	TS38302	133	Jersey Chair
474410M	251	Snodgrass 474 Multi-Purp Chr	TS38303	138	Jersey Pullover
474419M	251	Snodgrass 474 Multi-Purp Chr	TS38304	134	Jersey Chair
474419W	251	Snodgrass 474 Multi-Purp Chr	TS38305	134	Jersey Chair
474420M	251	Snodgrass 474 Multi-Purp Chr	TS38306	135	Jersey Chair
474427W	251	Snodgrass 474 Multi-Purp Chr	TS38307	135	Jersey Chair
474429M	251	Snodgrass 474 Multi-Purp Chr	TS38308	136	Jersey Chair
474429W	251	Snodgrass 474 Multi-Purp Chr	TS38309	136	Jersey Chair
475410M	233	Player 475 Leg-Base Multi-Purp Chr	TS38310	137	Jersey Chair
475410MB	233	Player 475 Leg-Base Multi-Purp Chr	TS38311	137	Jersey Chair
475410MTL	235	Player 475 Leg-Base Multi-Purp Chr			
475410MTLB	235	Player 475 Leg-Base Multi-Purp Chr			
475410MTR	235	Player 475 Leg-Base Multi-Purp Chr			
475410MTRB	235	Player 475 Leg-Base Multi-Purp Chr			
475412M	233	Player 475 Leg-Base Multi-Purp Chr			
475412MB	233	Player 475 Leg-Base Multi-Purp Chr			
475412MC	233	Player 475 Leg-Base Multi-Purp Chr			
475415M	233	Player 475 Leg-Base Multi-Purp Chr			
475415MB	233	Player 475 Leg-Base Multi-Purp Chr			
475415MC	233	Player 475 Leg-Base Multi-Purp Chr			
475480M	237	Player 475 Sled-Base Multi-Purp Chr			
475480MB	237	Player 475 Sled-Base Multi-Purp Chr			
475480MTL	239	Player 475 Sled-Base Multi-Purp Chr			
475480MTLB	239	Player 475 Sled-Base Multi-Purp Chr			
475480MTR	239	Player 475 Sled-Base Multi-Purp Chr			
475480MTRB	239	Player 475 Sled-Base Multi-Purp Chr			
475482M	237	Player 475 Sled-Base Multi-Purp Chr			
475482MB	237	Player 475 Sled-Base Multi-Purp Chr			
475485M	237	Player 475 Sled-Base Multi-Purp Chr			
475485MB	237	Player 475 Sled-Base Multi-Purp Chr			
475710M	241	Player 475 Leg-Base Stool			
475710MB	241	Player 475 Leg-Base Stool			
475712M	241	Player 475 Leg-Base Stool			
475712MB	241	Player 475 Leg-Base Stool			
475715M	241	Player 475 Leg-Base Stool			
475715MB	241	Player 475 Leg-Base Stool			
475A	242	Player 475 Alignment Device			
475B	242	Player 475 Bookrack			
475D	243	Player 475 Transport/Strg Dolly			
475G	242	Player 475 Ganging Device			
4871110	185	Cachet 487 Swivel-Base Multi-Purp Chr			
4871210	185	Cachet 487 Swivel-Base Multi-Purp Chr			
4871211	185	Cachet 487 Swivel-Base Multi-Purp Chr			

Trademark List

® The following registered trademarks are used under license from Steelcase Development Corporation: Accelerate, Addition, Ally, Answer, Anthem, Arrondi, Avenir, Ballet, Bix, Brayton International Collection, Brayton Textile Collection, Breton, Broadmoor, CaneCreek, Canto, Chancellor, Collegium, Company, Concentrx, Conjunction, Context, Criterion, Crushed Can, Decorum, Designtex, Details, Diva, Drive, Elective Elements, Ellipse, Ember Chrome, Emerge, Etude, Exclamation Mark, Firstfile, Gentry, Ginkgo, Ginkgo Biloba, Hardwear, Ideo, Internode, Jersey, Kart, Kick, LaCosta, Latour, Leap, Let's B, Lucy, Lyra, Lytyn, Manhattan Product Configuration, Max-Stacker, Media Dock, Metro, Migrations, Miko, Montage, Oriana, Paladin, Paperflo, Parade, Paradigm, Pathways, Perfect Match, Player, Power Pincher, Portal, Protégé, Raf System, Rally, Rapport, Relevant, Reply, Secant, Segment, Sensor, Series 9000, Springboard, Steelcase, Steelcase Design Partnership, Steelcase Workplace Performance, Stow Davis, TeamWork, Technique, Texpress, Treehouse, Trilogy, Turnstone, Valencia, Vecta, Vectaflex, Werndl, Wizard, and Workflo.

® The following is a registered trademark of Genlyte Thomas Company, Louisville, KY: Lightolier.

® The following is a registered trademark of Leviton Manufacturing Company, Little Neck, NY: Decora.

® The following is a registered trademark of Microsoft Corporation, Redmond, WA: Microsoft.

® The following is a registered trademark of Panduit Corporation, Lockport, IL: Panduit.

® The following is a registered trademark of Trav (Press), Cuneo, Italy: Assisa.

® The following is a registered trademark of Virtual Ink Corporation: mimioActive.

® The following registered trademarks are under license from Wilkhahn Furniture Products: Avera, Confair, Senzo, Versal, and Wilkhahn FS.

™ The following trademarks are used under license from Steelcase Development Corporation: 4 o'clock, à la carte, Active/Passive Shelf, Activity Products, Adia, Alcove, Alerion, Alexander Street Collection, Aliso, Allegro, Alongside, American Elect, American Tradition, Anson, Arbor, Archipelago, Archive Collection, Arriva, Ascot, Astor, Austin, Avalon, Bira, Bonn, Boomerang, Bradbury, Breadbox, Brio, Buxton, Cachet, Callahan, Camber, Canopy, Cappucino, Catalina, CbP, Chester, Chorus, Chronos, Churchill, Ciao, Clarendon, Classic Rectangular, Collaboration, Collins, Cologne, Colorbox, Common (Shelf), Commons, Community, Community Base Planning, Convene, Convey, Cortex, Cosima, Croix, Cubby, Cubis, Cushion, Customiz, Dataduct, Datum, Debut, Deck, Dedoes, Déjà, Detour, Detriana, DNA, Domain, Donovan, Dorchester, Downspout, Drop Top Hutch, Duospace, Eastlake, Eastridge, Eco, Ella, Elsa, Emmy, Encounter, Enea, EnSync, Ensemble, Entourage, Environmental Impact Collection, Equinox, Escapade, Et Al, E-Table, Exponents, Express12, Extreme Conditions, Fillmore, Flat Top, Fling, Flip Top, Footnote, Fortuna, Frontier, Fuji, Futu, Galilei, Galveston, Garland, Ginger, Glenwood, Go Wall, Greco, Greenbrier, Grip, Groove, Groupwork, Hannah, Hatch, Hatchback, Hatteras, Health Design, Hitch, Huddleboard, Impact, Incognito, Indy, InfoWizard, InterAct, IOS, I-Solve, Jacket, Jenny, Jetty, Juice, Kendo, Kiana, L'Attitude, Lazlo, Lean Too, Lemon, Lift-N-Slide, Lotus, Lyric, M/O, Malibu, Manhattan, Mansfield, Martini, Masque, Mingle, Monarch, Monterey, Montreal, MyWizard, Nadia, Nickel, Nine, Ontrak, Onyx, Outlook, Paloma, Parliament, Parts Advantage, Pasio, Passarelle, Patriarch, Patterson, Payback, Peek, Pendio, Personal Border, Pier Top, Pipe, Pisa, Playback, Portal, Progeny, Quotient, Radio, Rag Top, Rei, Request, Reunion, Rhine, Rialto, Ricetta, Riser, Rizzi Arc, Rocco, RoomWizard, Rover, Runaround, Runner, Satellite, Scribe, Shadow, Shield, Shortbed, Skinny, Sidebar, Sidewalk, Sieste, Sine, Smoke, Snug, Softwork, Spinz, Sportswear, St. Clair, Stafford, Stationkits, Stiletto, Stuttgart, Super Shelf, Surprise!, Switch, Tableau, Taco, Template, Terrazzo, Tessare, Theorem, Think, Topaz, Topo, Top Spin, Touchdown, Translations, Train, Trolly, T-Wall, Umbrella, Underline, Unison, Uno, Utility Bar, Venetia, Walden, Warehouse, Whittier, Windsor, Wizard WebSigns, Your Profile, Your Power, and Your Preference.

™ The following is a trademark of Microsoft Corporation, Redmond, WA: Windows.

™ The following is a trademark of Ultrafabrics, LLC, Elmsford, NY: Ultraleather.

™ The following trademarks are used under license from Wilkhahn Furniture: Cana, Linus, Logon, Picto, Range, Stitz, Thema, Timetable, and Tubis.